



iAM-12G-SDI

**2RU, 4K/12G Multi Channel, Touch Screen
Audio/Video Monitor**

User Guide

Part Number 821827, Revision K

© 2023 Wohler Technologies, Inc. All rights reserved.

This publication is protected by federal copyright law. No part of this publication may be copied or distributed, stored in a retrieval system, or translated into any human or computer language in any form or by any means electronic, mechanical, manual, magnetic, or otherwise, or disclosed to third parties without the express written permission of Wohler Technologies.

Reproduction

Licensed users and authorized distributors of Wohler Technologies, Inc. products may copy this document for use with Wohler Technologies, Inc. products provided that the copyright notice above is included in all reproductions.

Customer Support

Wohler Technologies, Inc.
1280 San Luis Obispo Ave
Hayward, CA, 94544
Phone: 510-870-0810
Web: www.wohler.com
Sales: sales@wohler.com
Support: support@wohler.com

Disclaimers

Even though Wohler Technologies, Inc. has tested its equipment and software, and reviewed the documentation, Wohler Technologies, Inc. makes no warranty or representation, either express or implied, with respect to software, documentation, their quality, performance, merchantability, or fitness for a particular purpose.

In no event will Wohler Technologies, Inc. be liable for direct, indirect, special, incidental, or consequential damages resulting from any defect in the hardware, software, or its documentation, even if advised of the possibility of such damages.

Some states do not allow the exclusion or limitation for incidental or consequential damages, so the above exclusion or limitation may not apply to you.

Other Technologies and Products

Dolby and Dolby ATMOS are registered trademarks of Dolby Laboratories, Inc.
Google Chrome is a registered trademark of Alphabet Inc.
Microsoft Windows and Internet Explorer are registered trademarks of Microsoft Corporation.
MN-Set is a registered trademark of Embrionix.
Dante and Brooklyn are registered trademarks of Audinate Pty Ltd.
Ravenna is a registered trademark of ALC NetworX GmbH.
ZMAN and Aneman are registered trademarks of Merging Technologies.

All product names, logos, and brands are property of their respective owners. All company, product and service names used in this document are for identification purposes only. Use of these names, logos, and brands does not imply endorsement.

Last Update

November 8, 2023

TABLE OF CONTENTS

Table of Contents

User Guide	1
TABLE OF CONTENTS	3
Table of Contents	3
CHAPTER 1: Installation	7
Introduction	7
Overview	7
Safety	8
Instructions	8
Safety Symbols	8
Mounting	8
Heat Dissipation	9
Sympathetic Vibration	9
Mechanical Bracing	9
Electrical Interference	9
Power	9
Compliance	10
FCC	10
ICES-003	10
CHAPTER 2: Local Operation	11
Startup	11
Front Panel	11
Rear Panel	13
SFP-2022-6 / SFP-2110 Address Setup	19
Channel Meters and Touch Operations	20
Dolby Monitoring Screens	24
Wohler Zoom Screen	24
Dolby MetaData	29
Dolby ED2 Stream Selection and Decoding	31
Dolby Preset Monitoring Screen	32
Dolby® ATMOS Visualizer Screen	33
Menu / Option Touchscreen	35
Menu	36
Audio Meters	36
Source Select	37
Presets	38
Preset Favorites	39
All Presets	40
Loudness Meter	41
Loudness Settings	43
System Options	44
Dolby Settings	45

Network Settings.....	49
Output Configuration	51
Speaker Options.....	52
Meter Scales.....	53
App Settings.....	55
System Software Update	56
System Reboot	57
Factory Reset	58
System Information	59
Passcode Settings	61
Forgotten Passcode	63
CHAPTER 3: Technical Info	64
CHAPTER 4: The iAM-12G-SDI Web GUI.....	70
Web Browser / Control Device.....	70
First Time IP Assignments	70
Peer-to-Peer Connection.....	70
Network Connection.....	71
Dashboard	72
Preset Management.....	75
Preset Input Routing.....	75
Dolby Presets	80
MPEG-H Presets	83
Phase Indicators by Preset.....	85
Output Routing by Preset	86
Output Routing	87
Destination Outputs.....	88
Source Inputs	89
Output Options	89
Typical Questions Regarding Output Routing	90
What signal outputs can be controlled using the Output Routing feature? ...	90
How do the outputs behave in their factory default settings?	90
What is the difference between Global Output Routing and Output Routing in Presets?.....	90
How do I route whatever is being monitored to the Analog XLR outputs?	90
How do I have a downmixed pre-fade output on Analog DB-25 Pair-1 combined with a post-fade output on the Analog XLRs?.....	91
How do I make the XLR outputs follow the Audio Meter screen Solos and Mutes while the Analog DB-25 Pair-1 does not?	91
The Global Output Routing feature works great. But what if we don't want to create any Presets and want to monitor audio only using Source Select? How would I configure different outputs for Source Select choices?	92
How do I keep the internal speakers muted and have audio only on the analog XLR outputs?	92
How do I ensure that the outputs are automatically muted when the Headphone jack is inserted?.....	92
How do I ensure that my outputs are pre-faded but follow the solo-mutes? This will allow us to monitor only the unmuted/solo Audio Meter channels on amplified stereo speakers connected to the Analog XLR's.	93
Preset Replication.....	94
Remote Monitor	96
Audio Meters	96
Dolby Metadata.....	97

System Setup	102
System Information	102
SFP Information	103
Licenses	105
Configuration: Management IP Address	106
Configuration: System Preferences	107
Loudness Configuration	107
Phase Indicator Configuration	109
Dolby Settings	110
Front Panel Configuration Tab	112
Configuration: Import/Export Presets	115
Export Configuration	116
Import Configuration	116
System: Factory Reset	117
System: Reboot System	118
APPENDIX A: Software Upgrades	119
Introduction	119
Download the Software	119
Update Methods	119
Local Update from the Front Panel	120
Updating via the Web GUI using a Flash Drive	122
Updating an iAM-12G-SDI Remotely	124
Updating Multiple Units Remotely	126
APPENDIX B: Dante Network Setup	129
Introduction	129
What is in the iAM-12G-SDI for Dante	129
Dante™ Device Setup	131
Dante Clock Selection	132
Channel Names	132
AES67	133
Device Lock	134
Dante Firmware Upgrades	135
Additional Information	135
Dante™ Legal Disclosures	135
APPENDIX D: Ravenna (ZMAN) Setup	136
Introduction	136
What is in the iAM-12G-SDI for Ravenna	136
RAVENNA-Compatible Talker/Listener	136
AVB Ethernet Features	136
Configuring the AOIP Merging Option Card	137
Getting Started General Settings	138
Getting Started PTP	139
Getting Started Session Sources	140
Getting Started Session Sinks	141
Getting Started Session Info	142
Getting Started Ins/Outs	143
Getting Started I/O Router	143

Operation:	144
Connecting Remote Source to Local Sink	144
ZMAN Session Sinks	144
ZMAN Session Sources	146
ZMAN Updating	146
APPENDIX E: API Documentation	147
Introduction	147
API: Presets	147

CHAPTER 1: Installation

Introduction

Overview

The iAM-12G-SDI is a 2RU multichannel multi-source audio/video monitor with multiple standard copper connections and multiple SFP module options facilitating high density coax and optical fiber connections. The iAM-12G-SDI includes dual 12G SDI SFP inputs and it can monitor 12G/3G/HD/SD-SDI video and audio from the selected one.

An optional module allows decoding, monitoring, and metering of Dolby® ATMOS, E, DD+, and D from SDI, SMPTE 2110, SMPTE 2022-6, and AES streams. For those who do not at the present time require Dolby® ATMOS decoding, another optional module is available to decode, monitor, and meter Dolby® E, DD+, and D from SDI, SMPTE 2110, SMPTE 2022-6, and AES streams.

Another available option provides MPEG-H Audio monitoring support. It provides operators with an easy and accessible way to quality-check all MPEG-H Audio interactivity options just before the final transmission. The intuitive visual display and graphical user interface of the iAM-12G-SDI are similar to those used by at-home-audiences to interact with MPEG-H Audio content. They allow operators to switch between various presets, enhance the dialog, and dynamically position audio objects in the three-dimensional space.

Loudness of programs can be monitored using the ITU-R BS.1770-3 standard, and over/under visual loudness alarms can be set.

The iAM-12G-SDI has options for VoIP formats including SMPTE 2022-6, SMPTE 2022-7, 3G/HD/SD-SDI, and a growing range of additional I/O options via SFP interfaces. Refer to the Specifications section of this manual or contact Wohler Sales for more information.

The iAM-12G-SDI is compact and simple to operate. It has touch screen LCD displays providing high resolution meters, menus and basic monitoring controls. Any channel (or group of up to 16 channels that are clustered together) from any source stream may be audibly monitored and summed with the other selected channels to provide flexible monitoring capabilities.

Setups are created and configured using a web browser over a network connection to the integral web server of the iAM-12G-SDI. Level and Loudness metering may also be monitored using the integral web server.

Each iAM-12G-SDI can be configured with Presets, which are complete monitoring configurations. Very little about the configurations of those predefined setups can be changed from the front panel. This prevents less experienced or hurried operators from making accidental setup changes that could compromise their usage of the unit. It also reduces operator training to a minimum.

Safety

Instructions

1. Read, keep, and follow all of these instructions; heed all warnings.
2. Do not use this equipment near water.
3. Use only a dry cloth to clean the equipment.
4. Do not block any ventilation openings.
5. Do not install near any heat source such as a radiator, heat register, amplifier, or stove.
6. Do not attempt to plug the unit into a two-blade outlet (with only two prongs of equal width).

Important:

By design, the supplied AC mains power cord will only plug into a three-prong grounded outlet for your safety. If the plug does not fit into the outlet, contact an electrician to replace the obsolete outlet.

7. Protect the power cord from being walked on or pinched, particularly at plug connection on the equipment and at the socket.
8. Use only the attachments/accessories specified by the manufacturer.
9. Unplug the equipment during lightning storms or when unused for long periods of time.
10. Refer all servicing to qualified service personnel. Servicing will be required under all of the following conditions:
 - a. The equipment has been damaged in any way, such as when the power-supply cord or plug is damaged.
 - b. Liquid had been spilled or objects have fallen onto the equipment.
 - c. The equipment has been exposed to rain or moisture.
 - d. The equipment does not operate normally.
 - e. The equipment has been dropped.

Safety Symbols

WARNING:

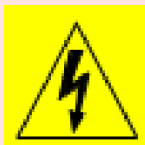

The symbol to the left warns of electric shock hazard inside the unit. Disconnect the power cord before removing access panels when installing upgrades. Only qualified service personnel are to operate the equipment with covers removed, and are to exercise caution to avoid personal injury.

Mounting

The unit is designed for a standard 19" rack. Install it at ear/eye level for best high frequency response and visual observation of the display screens. Please adhere to the following clearances:

Table 1-1: Clearance Recommendations

Clearance	Surface
24"	Front
3"	Rear
2"	Sides
1.75"	Top and Bottom (if either radiates heat)
0"	Top and Bottom (if no heat)

Heat Dissipation

The ambient temperature inside the mounting enclosure should not exceed 40° Celsius (104° Fahrenheit). Adjacent devices can be rack mounted (or stacked) in proximity to the unit if this temperature is not exceeded. Otherwise, allow a 1RU (1.75"/44.45mm) space above and below the unit for air circulation.

Important

Heat generated by the class D power amplifiers, power supplies, and other components is vented by slots in the sides and back of the unit. Therefore, as a safety precaution, you must allow proper ventilation on these surfaces.

Sympathetic Vibration

Sympathetic vibration from other equipment (cables, etc.) in the rack may be serious enough to interfere with the unit's sound quality. If you experience sympathetic vibrations, use thin card stock, felt, foam, or weather-stripping between the vibrating surfaces. Tie loose cables securely with cable ties.

Mechanical Bracing

Both the 1RU chassis and the 2RU chassis are securely attached to the front panel. In addition, the chassis has mounting tabs through which you attach it to the rack rail. This feature will reduce or eliminate rear bracing requirements in many mobile/portable applications. The weight of internal components is distributed fairly evenly around the unit.

Electrical Interference

Be careful to avoid mismatched cable types and other similar causes of undesired reflections in digital signal systems. If severe enough, such reflections can result in corruption of the digital data stream. As with any audio equipment, maximum immunity from electrical interference requires the use of shielded cable; however, satisfactory results can sometimes be obtained without it. The internal circuitry ground is connected to the chassis.

Power

The unit connects to an AC mains power source (100 to 240 VAC, 1.5A, 50/60Hz) using a supplied IEC power cord.

When the mains plug or appliance coupler is used as the disconnect device, the disconnect device should remain operable.

Compliance

FCC

This equipment has been tested and found to comply with the limits for a Class A digital device, pursuant to part 15 of the FCC Rules. These limits are designed to provide reasonable protection against harmful interference when the equipment is operated in a commercial environment. This equipment generates, uses, and can radiate radio frequency energy and, if not installed and used in accordance with the instruction manual, may cause harmful interference to radio communications. Operation of this equipment in a residential area is likely to cause harmful interference, in which case the user will be required to correct the interference at their own expense.

ICES-003

This Class A digital apparatus complies with Canadian ICES-003.

Cet appareil numérique de la classe A est conforme à la norme NMB-003 du Canada.

CHAPTER 2: Local Operation

Startup

The iAM-12G-SDI unit will begin its startup process when it is connected to power. There is no power switch. It is normal for the product to require about a minute to start up and be ready to use.

When the iAM-12G-SDI completes its startup, the **Power** indicator will turn green. Depending upon optional settings, all channel clusters will either be in the muted condition or set in a predetermined way. You may then touch the meter clusters on the screen to mute, unmute, or solo channel clusters as needed.

Front Panel

The front panel is shown in Figure 2-1.

Figure 2-1: iAM-12G-SDI Front Panel

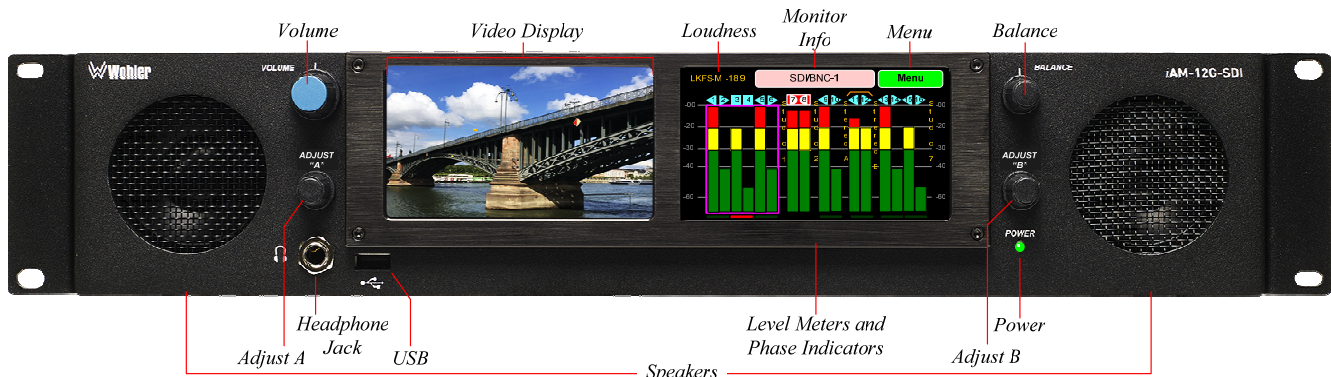

1. **Speakers:** Local near field audio monitoring is achieved through the use of class D amplifiers. There are two (left/right) full range speakers. The speaker response may be adjusted with tone controls. Refer to the **Speaker Options** section of this chapter.
2. **Video Display:** The selected SDI video signal is monitored on this screen.
3. **Headphone Jack:** A 1/4" jack for an optional headphone is provided on the front panel. Speaker audio optionally mutes when headphones are plugged in.
4. **Volume:** This controls the speaker and headphone output level for the entire mix. Pressing the knob alternately mutes and unmutes the speaker audio. As you rotate the knob, the Monitor Info box at the top center of the screen temporarily changes to an indicator of the Volume setting:  The range is from 0 to

1023.

5. **Balance:** This controls left/right levels for the stereo mixes. By default, it controls loudspeaker and headphone output. As you rotate the knob, the Monitor Info box at the top center of the screen temporarily changes to an indicator of the Balance setting: 
6. **Adjust A Knob:** This control can be rotated to move the orange Loudness Selection bracket from channel cluster to channel cluster. The Loudness indication then displays the loudness of the selected cluster. Pressing the **Adjust A** knob causes the Monitor Info display to show either the selected input source or the video mode of the incoming signal. It can also have other purposes, depending upon the needs of various screens and menus.
7. **Adjust B Knob:** Turning this control right or left moves a white selection box from channel to channel on the metering screen. Pressing the **Adjust B** control solos the selected channel. If a muted channel is selected with this control, it is unmuted and soloed. Pressing the **Adjust B** control again or touching the meter area anywhere removes the channel solo. On units equipped with the Dolby Decode option, if the **Adjust B** control is used to select a Dolby stream and then pressed, the Wohler Zoom feature will activate and display the channels within the Dolby signal, as well as Dolby MetaData.
8. **USB 2.0 Port:** This USB Type A connector allows you to use a flash drive (not supplied) to perform software updates and copy system configurations to another iAM-12G-SDI or to a PC. Software updates are accomplished from the Web GUI.
9. **Level Meters:** High resolution bar graph meters appear here showing the levels of up to 16 channels selected for monitoring. These can be grouped into clusters as specified in the Web GUI: mono clusters (1.0), pair clusters (2.0), or surround sound clusters. This screen will respond to touch control of audio Mute, Unmute and Solo. Access to the Menu screens is also available on this screen. The meter display is temporarily replaced when menu access is needed. These menus are used for setup and status display.
10. **Phase Indicators:** There is one Phase Indicator per channel pair. It is dark green when the channels are in phase and bright red when they are out of phase. Using the **Configuration | System Preference | Phase Indicator Configuration** tab in the Web GUI, you may determine which channel pairs should have a Phase Indicator and which shouldn't, for example, because they contain unrelated signals.
11. **Loudness:** The Loudness of the selected channel cluster is displayed here. Use the Adjust A knob to select the channel cluster to be monitored.
12. **Monitor Info:** Generally, the name of the current Input Source is displayed here. The SDI signal format, HDR detection, or other channel setup information may alternatively be displayed by pressing the **Adjust A** knob.
13. **Menu:** Touch to reveal the Menu. Refer to the **Menu / Option Touchscreen** section of this chapter.
14. **Power:** This indicator lights green when the system is powered and ready for use. A solid or blinking red or yellow color indicates that the product is starting up.

Rear Panel

The rear panel is shown in Figure 2-2.

Figure 2-2: iAM-12G-SDI Rear Panel Layout

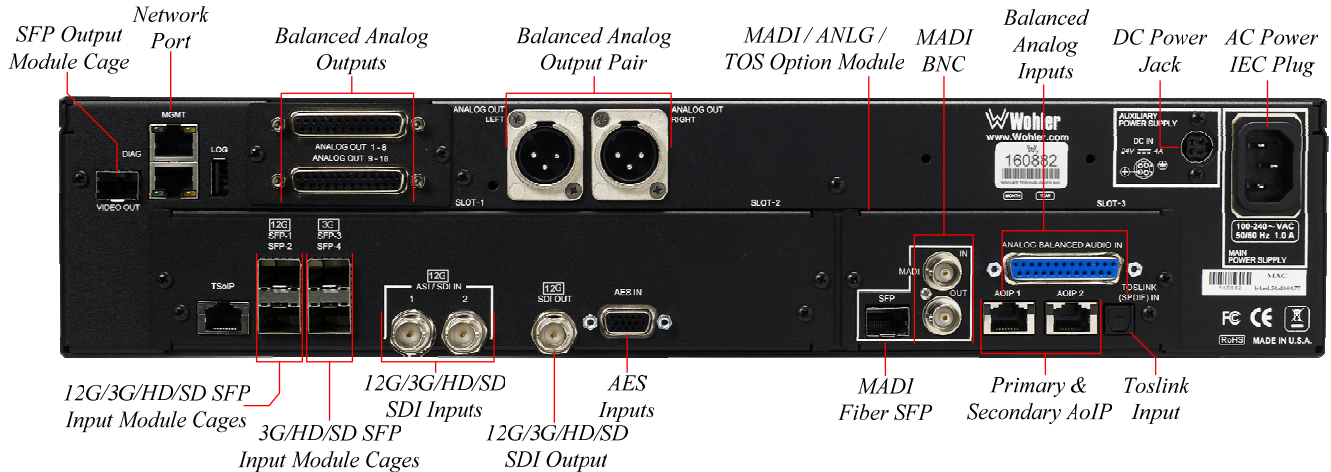

1. **AC Power IEC Plug:** The AC inlet is a standard IEC receptacle for 100 to 240 VAC $\pm 10\%$, 50/60 Hz power connection. Four regional AC power cords, supplied according to shipping region, are available.

Important:

By design, the supplied AC mains power cord will only plug into a three-prong grounded outlet for your safety. If the plug does not fit into the outlet, contact an electrician to replace the obsolete outlet.

2. **DC Power Jack:** An additional DC power inlet is provided for backup power, if needed. This could be an external AC to 24V DC 4A power adaptor or a 24V battery. This connection is by means of a locking DC connector. This is a 4-pin connector, but only two pins are used. The pinout is shown on the back panel and in Figure 2-3.

Figure 2-3: Backup Power Connector Pinout

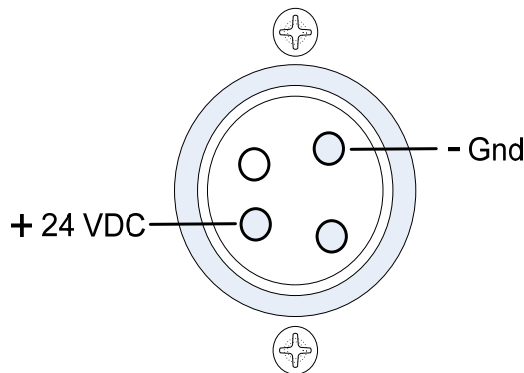

3. **Network Port:** The MGMT Ethernet port can connect to either a LAN or to a PC to let you customize the iAM-12G-SDI configuration remotely. The Wohler Web GUI is described in Chapter 4 of this manual.
4. **12G/3G/HD/SD-SDI Inputs:** Two inputs are provided to interface to a range of video signal inputs up to UHD 4K resolution. The internal monitoring screen displays the video at 480 x 272 resolution.
5. **12G/3G/HD/SD-SDI Output:** The selected 12G/3G/HD/SD-SDI input or from any selected 12G/3G/HD/SD-SDI SFP module input is reproduced on this output.
6. **12G/3G/HD/SD SFP Input Module Cages:** These two SFP Input cages are provided to accept 12G/3G/HD/SD optional SFP modules compatible with SDI coaxial or optical signals. Single or dual transceiver arrangements are possible. The SFP modules are hot swappable for convenience. An optional license key must be purchased to enable each module. A software license must be installed for an SFP port to function. Contact Wohler Technical Service to install software licenses. The following SFP modules are compatible with these inputs:
 - a. **SFP-2110 EMBER+** (829086): This is a SMPTE 2110 EMBER+ receiver that can receive streams up to 3G. It uses Multi-Mode 850 NM, LC fiber connectors. It allows the iAM-12G-SDI to monitor SDI audio transmitted in real time over Ethernet. You must use the MN-Set configuration software to set up this option. It is available from Wohler Technologies Technical Service.
 - b. **SFP-2110 NMOS** (829086-1): This is a SMPTE 2110 NMOS receiver that can receive streams up to 3G. It uses Multi-Mode 850 NM, LC fiber connectors. It allows the iAM-12G-SDI to monitor SDI audio transmitted in real time over Ethernet. You must use the MN-Set configuration software to set up this option. It is available from Wohler Technologies Technical Service.
 - c. **SFP-2022-6** (829088): This is a SMPTE 2022-6 receiver that can receive streams up to 3G. It uses Multi-Mode 850 NM, LC fiber connectors. It allows the iAM-12G-SDI to monitor SDI audio transmitted in real time over Ethernet. You must use the MN-Set configuration software to set up this option. It is available from Wohler Technologies Technical Service.
 - d. **SFP-2110 EMBER+ & 2022-6** (829087): This is a SMPTE 2110 EMBER+ or 2022-6 receiver that can receive streams up to 3G. It uses Multi-Mode 850 NM, LC fiber connectors. It allows the iAM-12G-SDI to monitor SDI audio transmitted in real time over Ethernet. You must use the MN-Set configuration software to set up this option. It is available from Wohler Technologies Technical Service.
 - e. **SFP-2110 NMOS & 2022-6** (829087-1): This is a SMPTE 2110 NMOS or 2022-6 receiver that can receive streams up to 3G. It uses Multi-Mode 850 NM, LC fiber connectors. It allows the iAM-

12G-SDI to monitor SDI audio transmitted in real time over Ethernet. You must use the MN-Set configuration software to set up this option. It is available from Wohler Technologies Technical Service.

- f. **SFP-SDI** (829089): This is a 3G/HD/SD-SDI Single Video Receiver with Active Loopback that can receive streams up to 3G. It uses HD-BNC connectors.
 - g. **SFP-12G-SDI-FIBER** (829160): This is a 12G/3G/HD/SD-SDI single-mode optical receiver. It uses LC fiber connections.
 - h. **SFP-SDI-FIBER** (829084): This is a 3G/HD/SD-SDI Video SFP receiver with optical input that can receive streams up to 3G. It uses LC fiber connectors. It is a Single-Mode Receiver, Medium Haul, Non-MSA, and has no output. It handles video only.
7. **3G/HD/SD SFP Input Module Cages:** These two SFP Input cages are provided to accept optional SFP modules compatible with 3G/HD/SD SDI coaxial or optical signals. Single or dual transceiver arrangements are possible. The SFP modules are hot swappable for convenience. An optional license key must be purchased to enable each module. A software license must be installed for an SFP port to function. Contact Wohler Technical Service to install software licenses. The following SFP modules are compatible with these inputs:
- a. **SFP-2110 EMBER+** (829086): This is a SMPTE 2110 EMBER+ receiver that can receive streams up to 3G. It uses Multi-Mode 850 NM, LC fiber connectors. It allows the iAM-12G-SDI to monitor SDI audio transmitted in real time over Ethernet. You must use the MN-Set configuration software to set up this option. It is available from Wohler Technologies Technical Service.
 - b. **SFP-2110 NMOS** (829086-1): This is a SMPTE 2110 NMOS receiver that can receive streams up to 3G. It uses Multi-Mode 850 NM, LC fiber connectors. It allows the iAM-12G-SDI to monitor SDI audio transmitted in real time over Ethernet. You must use the MN-Set configuration software to set up this option. It is available from Wohler Technologies Technical Service.
 - c. **SFP-2022-6** (829088): This is a SMPTE 2022-6 receiver that can receive streams up to 3G. It uses Multi-Mode 850 NM, LC fiber connectors. It allows the iAM-12G-SDI to monitor SDI audio transmitted in real time over Ethernet. You must use the MN-Set configuration software to set up this option. It is available from Wohler Technologies Technical Service.
 - d. **SFP-2110 EMBER+ & 2022-6** (829087): This is a SMPTE 2110 EMBER+ or 2022-6 receiver that can receive streams up to 3G. It uses Multi-Mode 850 NM, LC fiber connectors. It allows the iAM-12G-SDI to monitor SDI audio transmitted in real time over Ethernet. You must use the MN-Set configuration software to set up this option. It is available from Wohler Technologies Technical

Service.

- e. **SFP-2110 NMOS & 2022-6** (829087-1): This is a SMPTE 2110 NMOS or 2022-6 receiver that can receive streams up to 3G. It uses Multi-Mode 850 NM, LC fiber connectors. It allows the iAM-12G-SDI to monitor SDI audio transmitted in real time over Ethernet. You must use the MN-Set configuration software to set up this option. It is available from Wohler Technologies Technical Service.
 - f. **SFP-SDI** (829089): This is a 3G/HD/SD-SDI Single Video Receiver with Active Loopback that can receive streams up to 3G. It uses HD-BNC connectors.
 - g. **SFP-SDI-FIBER** (829084): This is a 3G/HD/SD-SDI Video SFP receiver with optical input that can receive streams up to 3G. It uses LC fiber connectors. It is a Single-Mode Receiver, Medium Haul, Non-MSA, and has no output. It handles video only.
8. **SFP Output Module Cage:** This SFP cage is provided to accept an optional SFP Output module compatible with SDI coaxial or optical signals. Single or dual transceiver arrangements are possible. The SFP modules are hot swappable for convenience. An optional license key must be purchased to enable the module. A software license must be installed for an SFP port to function. Contact Wohler Technical Service to install software licenses. The following SFP modules are offered:
- a. **SFP-SDI-OUTPUT** (829083): 3G-SDI Transmitter module; HD-BNC connectors; Audio and Video Output (video output at 1080p60) are from the monitored source.
 - b. **SFP-HDMI-OUTPUT** (829155): HDMI/DVI SFP; Video output at 1080p60 from the monitored source as well as two Audio Channels.
9. **Balanced Analog DB-25 Outputs:** These DB-25 female connectors output 16 channels of +10dBu broadcast level balanced audio. The source of these signals is the monitored audio channels as shown on meters 1 – 16. Tascam cables may be used, and can be purchased by contacting Wohler Sales. Refer to Figure 2-4 for the pinout of this pair of connectors. The **Balanced Analog DB-25 Outputs** are standard on the iAM-12G-SDI.

Note: PCM channels marked as data channels (such as those containing encoded Dolby streams) are automatically muted from being sent out to the external amplifier and speakers.

Note: When these outputs are used to connect to an external amplifier and speakers, the external amplifier should be muted whenever the iAM-12G-SDI is being powered up or powered down.

Figure 2-4: Analog DB25 Output and Input Connections

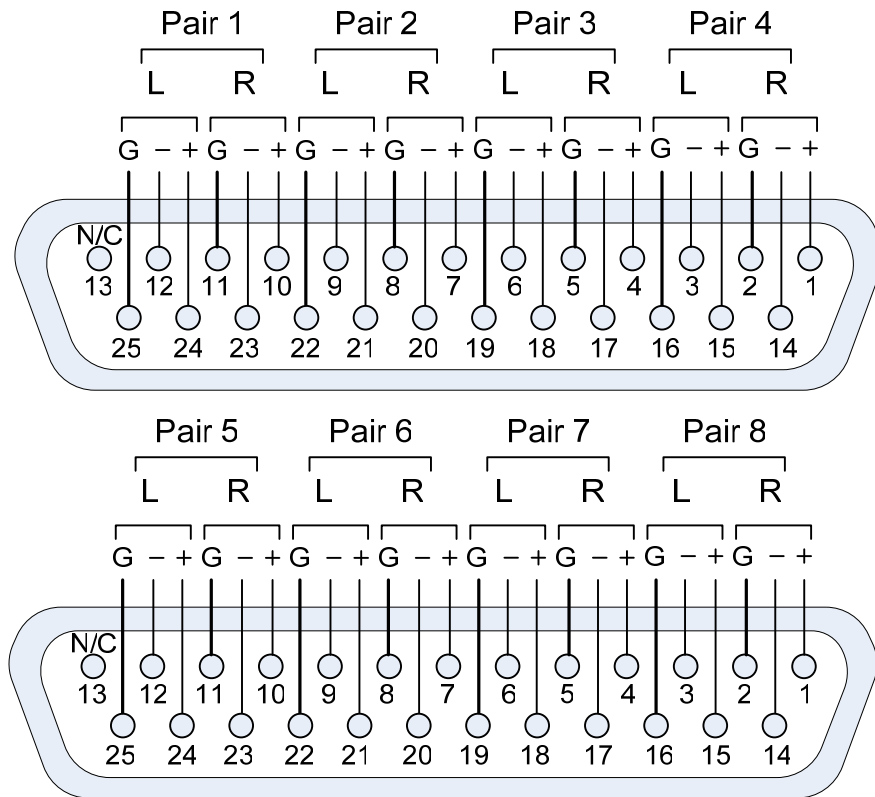

10. **Balanced Analog Output Pair:** These male XLR connectors provide two balanced analog outputs: Left and Right. The source of these signals is the mix of audio as monitored by the internal speakers. The **Balanced Analog Output Pair** is standard on the iAM-12G-SDI.

Note: PCM channels marked as data channels (such as those containing encoded Dolby streams) are automatically muted from being sent out to the external amplifier and speakers.

Note: When these outputs are used to connect to an external amplifier and speakers, the external amplifier should be muted whenever the iAM-12G-SDI is being powered up or powered down.

Figure 2-5: Analog XLR Output Connections

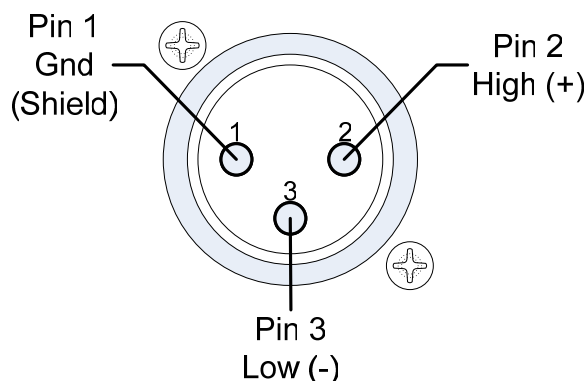

11. **AES Inputs:** This HD-15 connector is used to connect up to four AES inputs. Refer to Figure 2-6 for the pinout of this connector. The easiest way to interface with this connector is to use an HD-15 to VGA adaptor cable. Channels are selected as AES 1-8.

Figure 2-6: AES HD-15F Connector Pinout

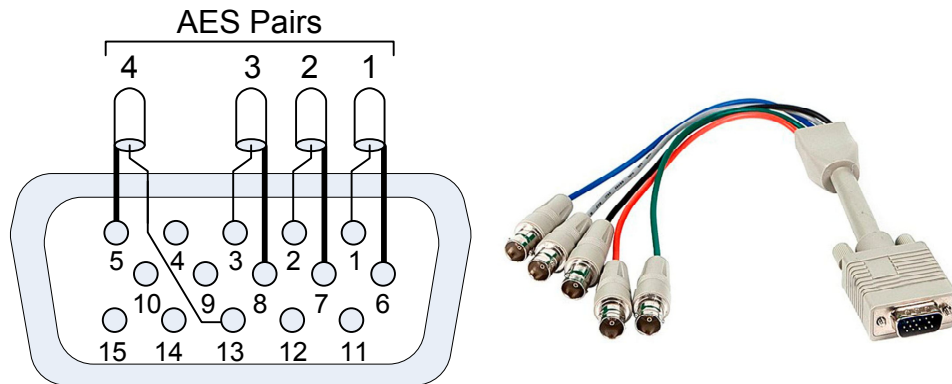

12. **MADI / ANLG / TOS Option Module:** A variety of inputs are contained in this module:
 - a. **MADI BNC:** This COAX input accepts an AES10 64-channel signal at a 48 kHz sample rate. The COAX output is reclocked from the MADI source. When power to the iAM-12G-SDI is not present, the COAX input and output are automatically connected together to allow the MADI signal to pass through.
 - b. **MADI Fiber SFP:** This SFP cage is for an optional SFP input module which accepts an optical AES10 64-channel MADI input signal at 48 kHz sample rate. A software license must be installed for the SFP port to function. Refer to the System Setup section in Chapter 4 to install software licenses.
 - c. **Balanced Analog Inputs:** This DB-25 female connector inputs 8 channels of up to +10dBu broadcast level balanced audio. Tascam cables may be used, and can be purchased by contacting Wohler Sales. Refer to Figure 2-4 (Pairs 1 – 4) for the pinout of this connector. Channels are selected as Analog 1-8.
 - d. **Primary and Secondary AoIP:** Primary and Secondary Gigabit Ethernet interfaces are provided for use with Dante64, Ravenna64 or SMPTE 2110-30/AES67. The two gigabit Ethernet interfaces provide hitless/SMPTE 2022-7 processing options.
 - e. **TOSLINK Optical Input:** This provides an optical stereo pair input.

SFP-2022-6 / SFP-2110 Address Setup

While the optional SFP-2022-6 and SFP-2110 modules monitor program audio created from distinctly different technologies, both are connected to the network in the same way and have the same requirements for addressing. Up to 3G SDI is supported by these modules. Figure 2-7 illustrates the network connections they need.

Figure 2-7: SFP-2022-6 and SFP2110 Network Diagram

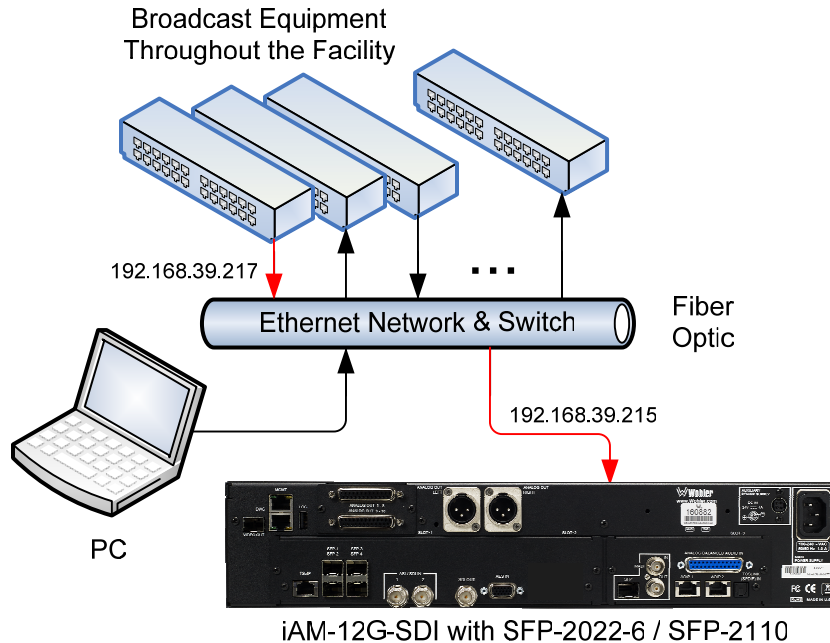

The optional SFP-2022-6 or SFP-2110 module furnished by Wohler Technologies is manufactured by Embrionix and comes from the factory with a default IP address. To integrate it into your digital network, you need to set its address to the source to be monitored. You must use the MN-Set configuration software to set up this option. It is available from Wohler Technologies Technical Service. The procedure to accomplish this is described in the **SFP-2022-6 / SFP-2110 Setup Guide** (part number 821822), which is available at <http://www.wohler.com/downloads>.

Channel Meters and Touch Operations

The audio mixer terminology of “solo” is used in this manual when referring to muting all but a specific audio channel or subgroup. Since the terms “group” and “subgroup” have different meanings in SDI vs. pro audio, this manual uses the term “cluster” to define a set of audio channels forming an audio program—such as Mono (1.0), Stereo (2.0) or Surround (5.1 or 7.1).

Important:

The numbers for each meter bar graph position only indicate its relative position on the display, and not any particular channel number. Meter numbers only serve as references for monitor configurations at the Web GUI level.

Audio meters are displayed on the touchscreen display in labeled clusters, as shown in Figure 2-8. The clusters of channels and other options relating to this are defined using the iAM-12G-SDI Web GUI software as described in Chapter 4.

Figure 2-8: Audio Level Meter Screen

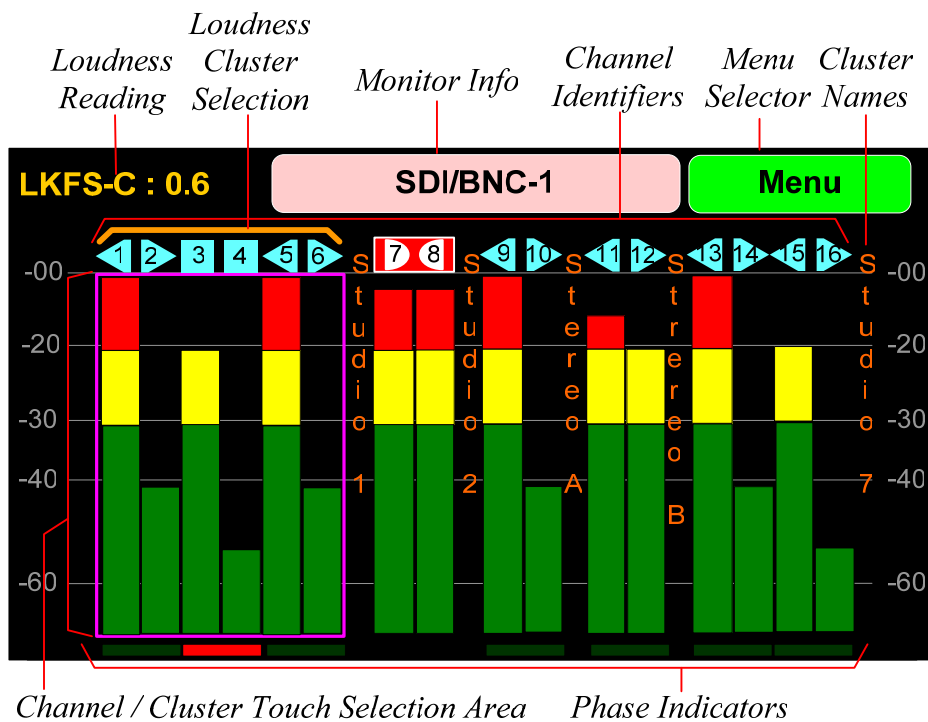



1. **Channel Identifiers:** Above the level meters are the Channel Identifiers. They indicate the following:

- 1 An arrow pointing to the left indicates that this is a left channel and will be monitored in the left speaker.
- 2 An arrow pointing to the right indicates that this is a right channel and will be monitored in the right speaker.

- 

A square indicates that this is a center channel and will be monitored in both speakers.
- 

The symbol shown on channels 7 and 8 in Figure 2-8 indicate that this channel pair is a Dolby bitstream. Refer to the **Wohler Zoom** section of this chapter.
- 

If these symbols appear on a channel pair, they indicate that this channel pair is a Dolby bitstream, but that the Dolby Decoder within the iAM-12G-SDI is still booting up and that you may not yet select the Wohler Zoom function on them. The Dolby Decoder takes about 90 seconds to boot up when the system is first powered. Refer to the **Wohler Zoom** section of this chapter.
- 

Dolby D, DD+, and E decoding is an optional feature requiring either the OPT-DOLBY or the OPT-DOLBY ATMOS module. If these symbols appear on a channel pair, this means that a Dolby bitstream was detected but that a Dolby module or license is not present in the iAM-12G-SDI. Contact Wohler Technical Service to purchase a Dolby module or install software licenses.

The channel numbers within the symbols indicate the numbered position in the meter display, not the channel position within the monitored stream. Channel assignment is made in the **Configure Presets** page of the Web GUI.

2. **Monitor Info:** The name of the currently selected input signal source, Preset, or other data is typically shown here for your reference, although other information may be shown, such as **Volume** and **Balance** control positions as they are being adjusted. Pressing the **Adjust A** knob will cause this display to show various pertinent data, such as:

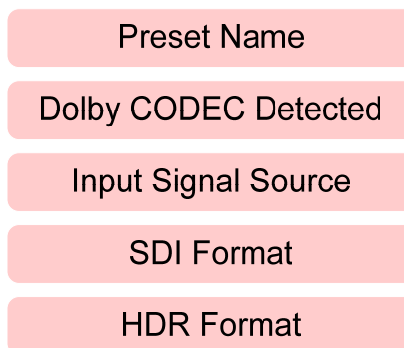

3. **Menu:** Touching the **Menu** selector proceeds to the **Menu**. Refer to Figure 2-13. The **Menu** provides a selection of option setting and system information screens.
4. **Cluster Names:** The descriptive names that you have given the channel clusters are displayed vertically for your reference.
5. **Channel / Cluster Touch Selection Area:** Touching the meters of a cluster will let you mute, un-mute, or solo the associated channel(s). Colored boxes surrounding the cluster or channel indicate what operation







is being performed. The following describes each function:

- a. **Mute / Un-Mute Selection:** A violet box surrounds any channel cluster that is muted. Typically, when the iAM-12G-SDI is first powered, all of the channel clusters are muted. Touching a muted channel cluster un-mutes it and removes the violet box. Muting and un-muting by touching is an alternate action function.
- b. **Solo Selector:** Touch any channel cluster you would like to solo. A blue box will then surround the cluster and that will be the only cluster you hear. Any violet boxes will disappear. Touch again to return the combination of monitored clusters to the way they were before you soloed the cluster.
- c. **Channel Solo:** Rotating the **Adjust B** control will move a white selection box from channel to channel. Press the **Adjust B** control to solo the selected channel. That channel alone will then be surrounded by a blue box and it will be the only channel being monitored. Press the **Adjust B** control again or touch anywhere on the meters to undo the solo and return the combination of monitored clusters to as it was before you soloed the channel. While the channel is soloed, pressing the **Adjust A** knob will cause the Monitor Info display to show the Channel Routing, for example:

BackSurroundLeft

- d. **Channel Routing:** After soloing a channel, rotating the **Adjust A** knob will allow you to reassign the Channel Routing for the soloed channel. The range of choices is shown in Table 2-1. **Make this choice thoughtfully and carefully because it will change what you see and hear while monitoring the audio sources from now on, or until you change it again. It will also affect the measurement of Loudness for the cluster(s) containing the channel(s).**

Table 2-1: Channel Identifiers

Channel Routing	Symbol
Left	
Right	
Center	
Low Frequency Effects	
Left Surround	
Right Surround	
Back Surround Left	



After adjusting the Channel Routing, press the **Adjust B** control again or touch anywhere on the meters to save the change and resume monitoring the combination of monitored clusters as before you soloed the channel.

6. **Phase Indicators:** There is one Phase Indicator per channel pair. It is pale green when the channels are in phase and bright red when they are out of phase. Using the **Configuration | System Preference | Phase Indicator Configuration** tab in the Web GUI, you may determine which channel pairs should have a Phase Indicator and which shouldn't, for example, because they contain unrelated signals.
7. **Loudness Reading:** The Loudness measurement readings can be viewed on the main **Meter Screen** in the upper left corner. It shows the loudness measurement calculated on the cluster denoted by the **Loudness Cluster Selection** bar. Loudness can also be viewed on a dedicated Loudness screen. Refer to the **Loudness Screen** section and to Figure 2-33 later in this chapter.
8. **Loudness Cluster Selection:** The **Loudness Cluster Selection** is a horizontal orange bracket which denotes which channel cluster is being measured for loudness. To make a different cluster selection, simply rotate the **Adjust A** knob. The orange bracket will move from cluster to cluster as you turn the knob and the loudness measurement will be restarted on the newly selected cluster.

Dolby Monitoring Screens

Wohler Zoom Screen

Wohler Zoom is a very powerful analysis tool. Much as a camera lens can “zoom” into a single subject of interest out of many, the **Wohler Zoom** feature lets you quickly “zoom” into a single Dolby bitstream, out of multiple encoded Dolby streams and other channels. Simply rotate the **Adjust B** control until the Dolby bitstream, as identified by the Dolby icon (shown here at right), is highlighted and then press the **Adjust B** control. You can immediately listen to and meter the contained audio channels, as well as view the Dolby MetaData. Bitstreams are shown distinctively along with the normal metering channels, as shown in Figure 2-8.



As shown in Figure 2-9, the Dolby CODEC being used to decode the monitored signal is shown in the information display at the center top of the Wohler Zoom screen. Dolby D, DD+, and E decoding is an optional feature requiring either the OPT-DOLBY or the OPT-DOLBY ATMOS module. Contact Wohler Technical Service to install software licenses.

The Wohler Zoom screen can be adjusted to show exactly the information you need. Figures 2-9 through 2-12 illustrate the variety of screens you can display.

Figure 2-9: Wohler Zoom Screen

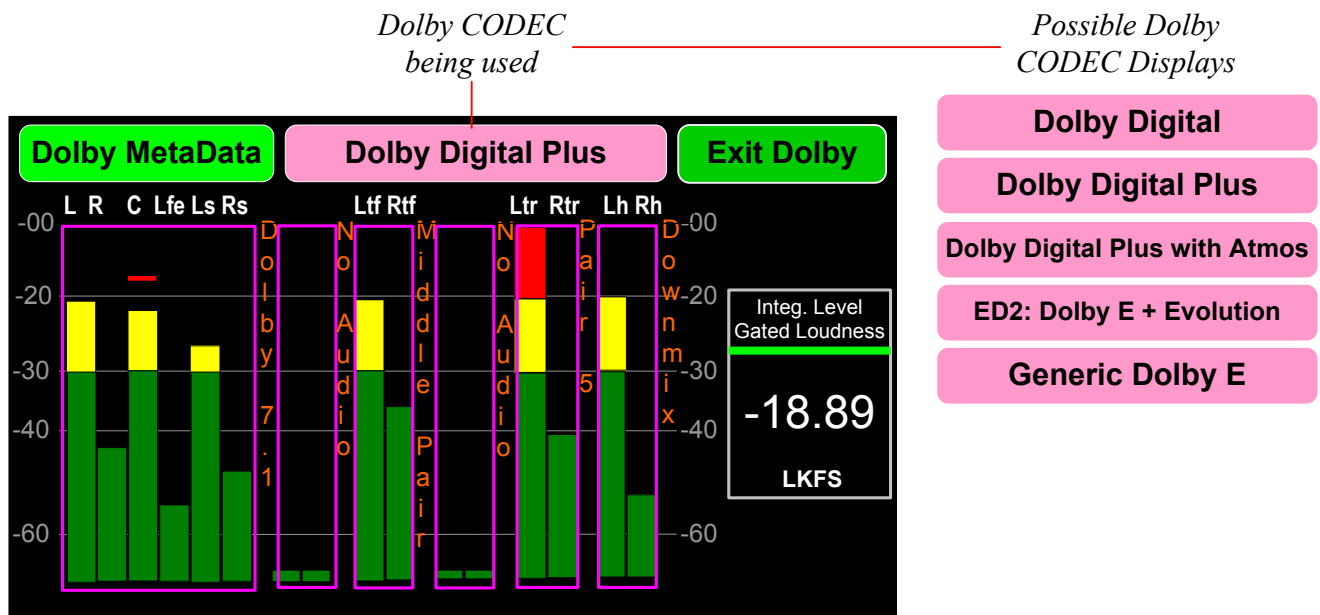

Wohler Zoom meters are customized to show Dolby related information. The clustering in Wohler Zoom is automatically selected based on the speaker configuration that the user selects in the Decoder configuration shown in Figure 2-36. When the **Wohler Zoom** screen appears, the speakers will be muted. You may then select the Downmix audio or any other clusters of channels. You may solo or mute the individual channels for troubleshooting or other purposes.

The Loudness parameters and values are shown on the right side of the meters. Rotate the **Adjust A** knob to cycle through the various loudness parameters. The Dolby integration provides various values that depend on the Loudness settings

defined above. Figure 2-9 shows an example of Integrated Level Gated loudness. Examples of other loudness measurements are shown in Figures 2-10, 2-11, and 2-12. The loudness measurements that may be shown are:

1. **Integ. Level Gated Loudness:** Loudness measurement is integrated over a period, but gated by speech levels exceeding a certain level.
2. **S.T. 10s Ungated Loudness:** Short Term Loudness is measured over a sliding 10 second interval.
3. **S.T. (3s):** Short Term Loudness is measured over a sliding 3 second interval.
4. **True Peak:** The True Peak Loudness is the loudest peak waveform over the program period.
5. **Loudness Range:** The Loudness Range (LRA) is the measure of variation between the calculated loudest and softest passage over the program period.
6. **Momentary:** Loudness is measured over a quick momentary interval.
7. **Dialnorm:** Loudness is measured according to the Dolby dialog normalization calculations.

Figure 2-10: Short Term (3s)

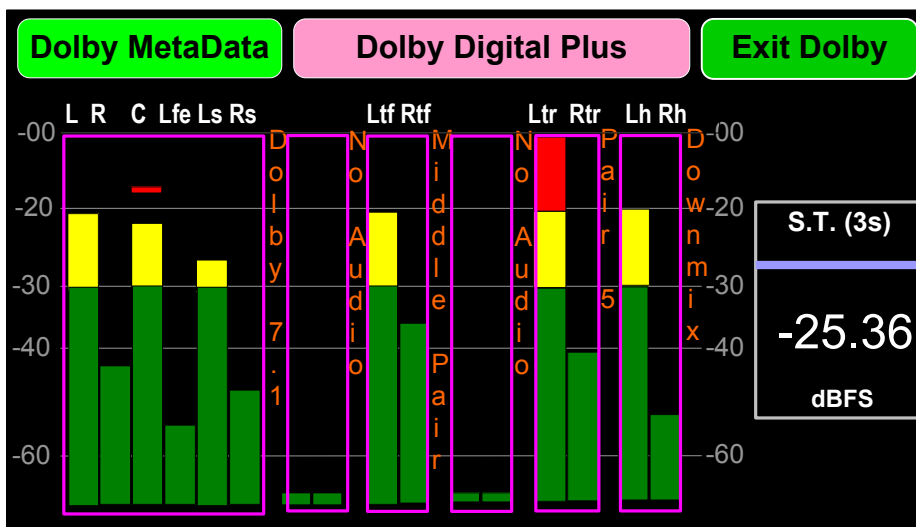

Figure 2-11: Short Term 10s Ungated Loudness

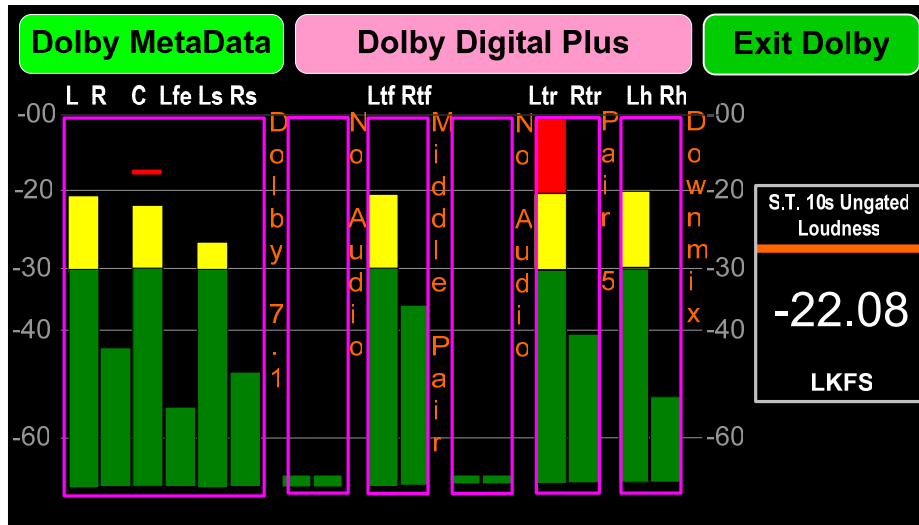
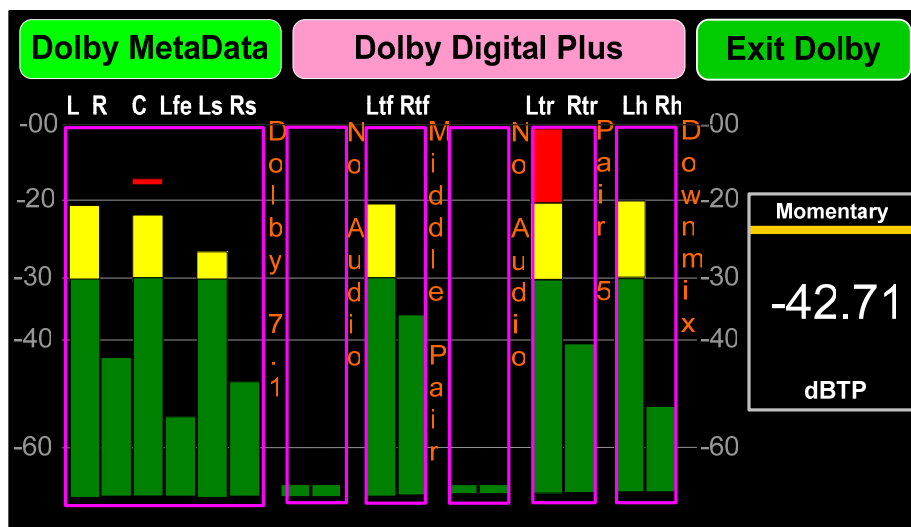

Figure 2-12: Momentary



To reset the loudness calculations, press and hold the **Adjust A** knob for 3 seconds until the red Resetting Loudness appears over the loudness measurement.

Note that above the channel meters are designations for each channel. These designations vary depending upon the Dolby speaker configuration. The various channel labels that may appear over the meters are shown in Table 2-2.

Table 2-2: Speaker Configuration versus Channel Labels

Speaker Config.	Channel															
	1	2	3	4	5	6	7	8	9	10	11	12	13	14	15	16
2.0	L	R	-	-	-	-	-	-	-	-	-	-	-	-	Lh	Rh
5.1	L	R	C	Lfe	Ls	Rs	-	-	-	-	-	-	-	-	Lh	Rh
7.1	L	R	C	Lfe	Ls	Rs	Lrs	Rrs	-	-	-	-	-	-	Lh	Rh
5.1.2	L	R	C	Lfe	Ls	Rs	-	-	-	-	Ltm	Rtm	-	-	Lh	Rh
5.1.4	L	R	C	Lfe	Ls	Rs	-	-	Ltf	Rtf	-	-	Ltr	Rtr	Lh	Rh
7.1.2	L	R	C	Lfe	Ls	Rs	Lrs	Rrs	-	-	Ltm	Rtm	-	-	Lh	Rh
7.1.4	L	R	C	Lfe	Ls	Rs	Lrs	Rrs	Ltf	Rtf	-	-	Ltr	Rtr	Lh	Rh

The speaker name abbreviations shown in Table 2-2 are explained in Table 2-3.

Table 2-3: Speaker Name Abbreviations

Abbreviation	Speaker Name
L	Left
R	Right
C	Center
LFE	Low Frequency Effects
Ls	Left Surround
Rs	Right Surround
Lrs	Left Rear Surround
Rrs	Right Rear Surround
Ltf	Left Top Front
Rtf	Right Top Front
Ltm	Left Top Middle
Rtm	Right Top Middle
Ltr	Left Top Rear
Rtr	Right Top Rear

Various Presentations in a Dolby ED2 stream may be selected and monitored. The selected Presentation is shown at the bottom center of the screen, as seen in Figure 2-13. Press the **Adjust A** knob to change between Presentations.

Figure 2-13: Dolby ED2 Presentations

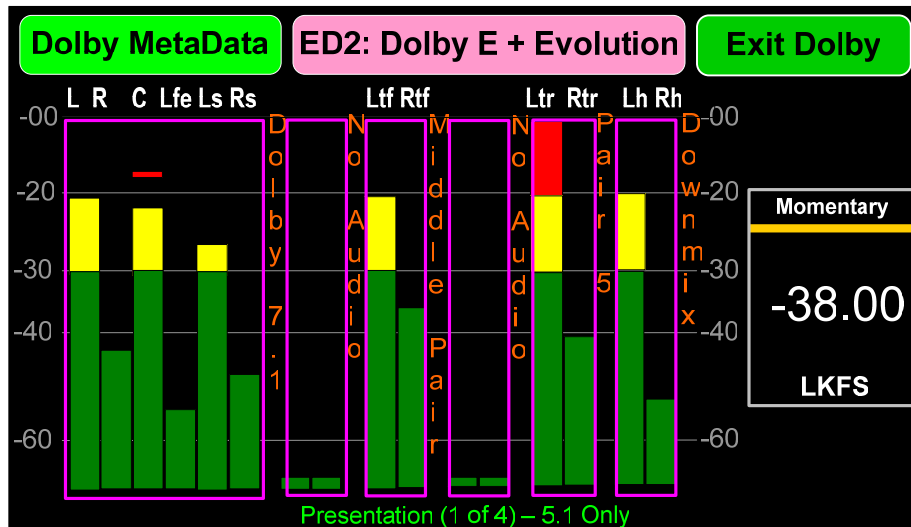

Various Programs in a Generic Dolby E stream may be selected and monitored. The selected Presentation is shown at the bottom center of the screen, as seen in Figure 2-14. Press the **Adjust A** knob to change between Programs.

Figure 2-14: Dolby E Programs

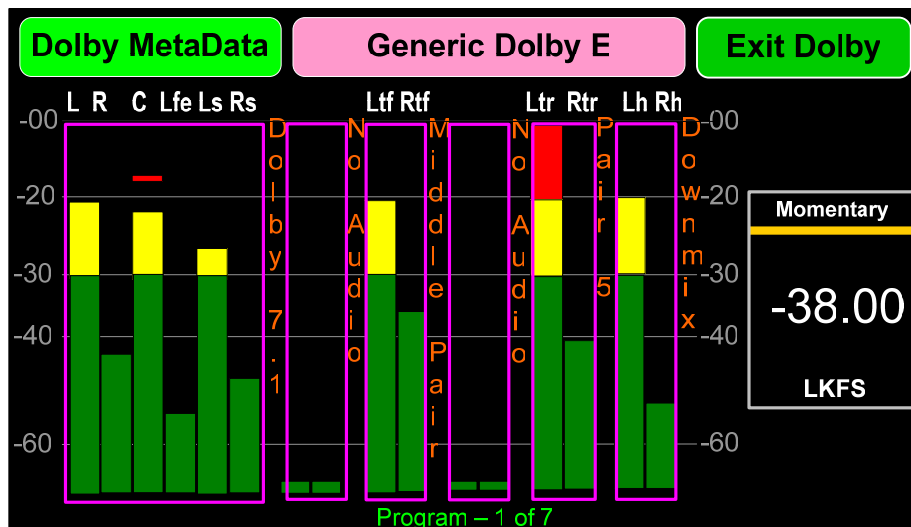

Dolby MetaData

Touching the **Dolby MetaData** button proceeds to the **Dolby MetaData Screen**. This screen has three forms, depending upon which tab you touch. These forms are shown in Figures 2-15, 2-16 and 2-17. Initially, when first touching the **Dolby MetaData** button, the screen shown in Figure 2-15 appears.

Figure 2-15: Dolby MetaData Screen

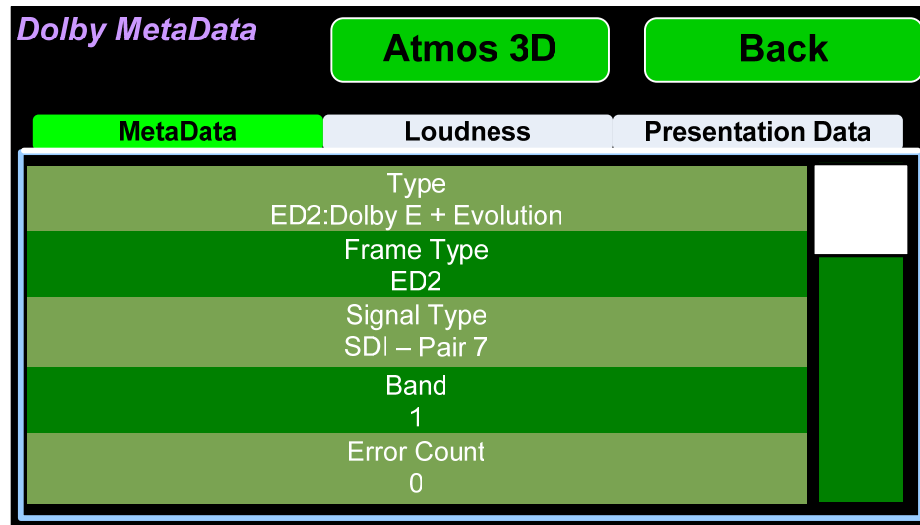

Touching and moving the scroll bar at the right will let you review the list of Dolby MetaData. Rotating the **Adjust B** knob will also let you scroll through the list. Touch the **Back** button to return to the Wohler Zoom screen from which you came.

A wide range of Metadata is available, which can help you diagnose possible problems. It will vary according to the type of Dolby signal. For example, for checking Guard Band, the iAM-12G-SDI will display the Line Position of each Dolby E bitstream of the Dolby signal. For Dolby ED2, two line positions will be displayed.

Also, the Dolby Metadata screen displays Dolby CRC (Cyclic Redundancy Check) Errors, which are automatically totaled. CRC Errors are an indication that the Dolby signal is being disrupted, either by intermittent network issues, poor wiring, or some other cause. Occasional errors probably cannot be heard, but this is a diagnostic tool that lets you measure the extent of the problem, if any.

Touching the **Loudness** tab on the **Dolby MetaData Screen** will show a variety of data related to the Loudness function. Figure 2-16 shows the **Dolby MetaData Screen** with the **Loudness** tab selected.

Figure 2-16: Dolby MetaData Screen Loudness Tab

MetaData	Loudness	Presentation Data	
Integ. Ungated Loudness	-120.00	S.T. 10s Ungated Loudness	-20.84
Integ. Level Gated Loudness	-19.72	S.T. 10s Gated Loudness	-120.00
Integ. Speech Gated Loudness	-120.00	S.T. 3s Ungated Loudness	-20.86
Integ. Loudness Range	7.57	Momentary Loudness	-25.39
Integ. Speech Percentage	-1.00	Sample Peak	-9.72
True Peak	-9.71	Dialnorm	-20.00

Touching the **Presentation Data** tab on the **Dolby MetaData Screen** will show data related to the audio bed and dynamic objects displayed on the **Visualizer Screen**. The audio bed is the arrangement of speakers in the listening room. The sounds produced by the audio bed accurately simulate the locations of the dynamic objects, which are heard as sound sources from any location in the listening room. The **Visualizer Screen** is described in the **Dolby ATMOS Visualizer Screen** section of this chapter. Figure 2-17 shows the **Dolby MetaData Screen** with the **Presentation Data** tab selected.

Figure 2-17: Dolby MetaData Screen Presentation Tab

Object #	Source	Gain	x	y	z	Class
1	0.00	4.00	0.77	-0.71	0.00	Dialog
2	0.00	0.00	-1.00	-0.00	0.00	Dialog
3	0.00	0.00	0.00	1.00	0.73	Dialog

The x, y, and z coordinates shown in the table on this tab describe the positions of the objects in the 3D screen as follows:

- For the x-coordinate, -1.0 means **left** and 1.0 means **right**.
- For the y-coordinate, -1.0 means **back** and 1.0 means **front**.
- For the z-coordinate, 0 means **floor**, 0.5 means **horizon**, and 1.0 means **ceiling**.

Numbers between the limits shown indicate the position of the object between **left** and **right**, between **back** and **front**, and between **floor** and **ceiling**.

Dolby ED2 Stream Selection and Decoding

Dolby ED2 streams can be carried over two SDI or AES channel pairs. The screen may appear as shown in Figure 2-18. Although both channel pairs will be indicated as containing a Dolby stream, **you must select the first (leftmost) of the two streams in order to zoom into it**. This is because the iAM-12G-SDI is not able to detect the start pair automatically. So in the case shown in Figure 2-18, you would select the stream indication on channel pair 7-8 for a Wohler Zoom.

Figure 2-18: Dolby ED2 Stream Selection

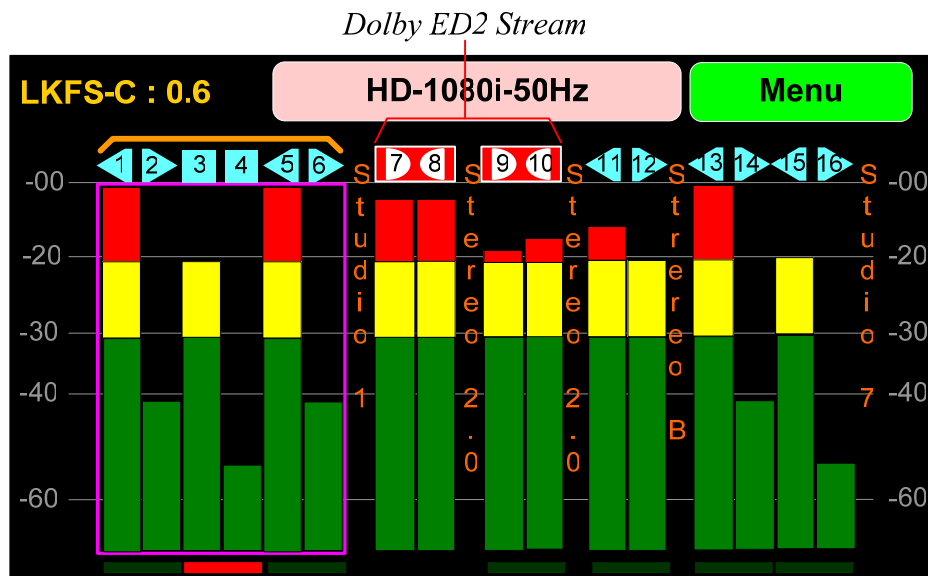

Note: If the iAM-12G-SDI has been configured to decode Pair-1 and Pair-2 as Dolby ED2, and if for some reason the configuration is changed so that Pair-1 now has no audio carried and Pair-2 now has PCM data, then the decoder will still keep decoding the 4 pairs of PCM data and will output the PCM data available on Pair-2.

Dolby Preset Monitoring Screen

When a Dolby Preset is being monitored, the Dolby codec currently being used can be displayed, as shown in Figure 2-19, at the center top of the screen.

Figure 2-19: Dolby Preset Monitoring Screen

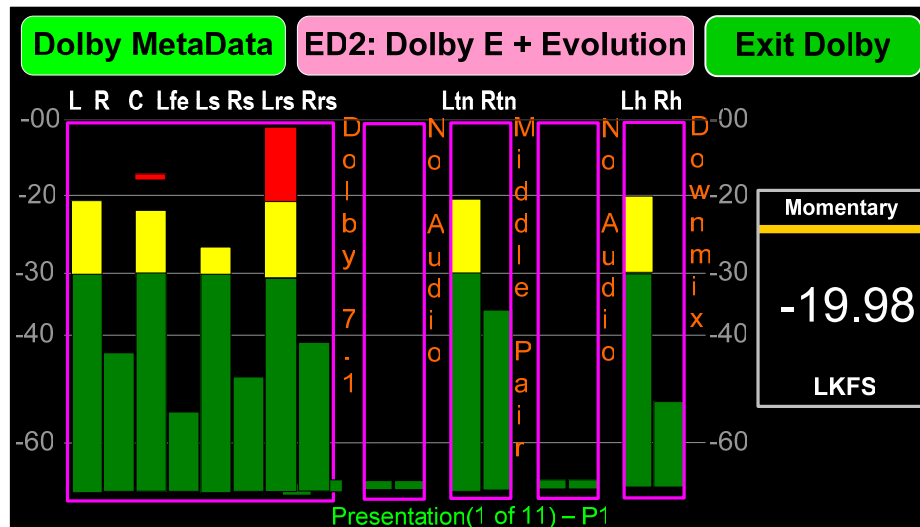

Note: If a Dolby Preset was selected as the iAM-12G-SDI is powered down, it will then reappear when the iAM-12G-SDI is powered up again. However, since the Dolby Decoder may take several minutes longer than the rest of the system to power up, the screen may appear as shown in Figure 2-20:

Figure 2-20: Dolby Decoder Startup Delay

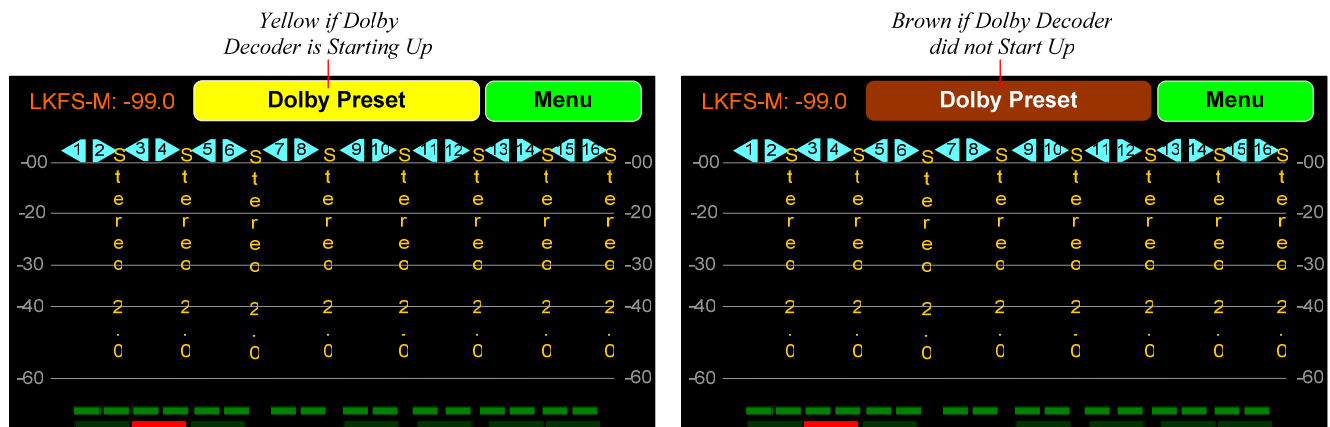

If the **Yellow** indication appears, then waiting a few minutes for the Dolby Decoder start up to complete will solve the issue and the expected Wohler Zoom screen will appear.

If the **Brown** indication appears, you may want to power the iAM-12G-SDI off and then re-power it. If the Brown indication appears on a regular basis, this may indicate a problem. Please contact Wohler Technical Service to resolve the issue.

Dolby® ATMOS Visualizer Screen

Dolby® ATMOS decoding is an optional feature requiring the OPT-DOLBY ATMOS module. It allows decoding of Dolby® ATMOS content, along with the familiar Dolby® D, Dolby® D+, and Dolby® E content. Because of the increased number of channels, up to 7.1.4, Dolby® ATMOS creates an amazing experience over speakers and over headphones, with breathtaking, moving audio that flows above and around you. Wohler's Dolby® ATMOS option allows broadcasters to confidently monitor the Dolby ATMOS® signal on the speakers and headphone output, view meters, access Wohler's proprietary Wohler Zoom functionality, review related MetaData, and route the audio externally to SDI or analog outputs on the rear panel.

To complement this feature, the iAM-12G-SDI contains a screen which can help you visualize the location of each audio bed or dynamic channel, both actual and dynamic channels. The audio bed is the arrangement of speakers in the listening room. The sounds produced by the audio bed accurately simulate the locations of the dynamic objects, which are heard as sound sources from any location in the listening room. The Dolby® ATMOS Visualizer Screen is available whenever Wohler Zoom is selected and is depicted in Figure 2.21.

Note: The **ATMOS Decode** setting in the Dolby Settings screen must be set to **ON** for the Dolby® ATMOS Visualizer screen to be available in the Dolby MetaData screen.

Figure 2.21 – Dolby® ATMOS Visualizer Screen

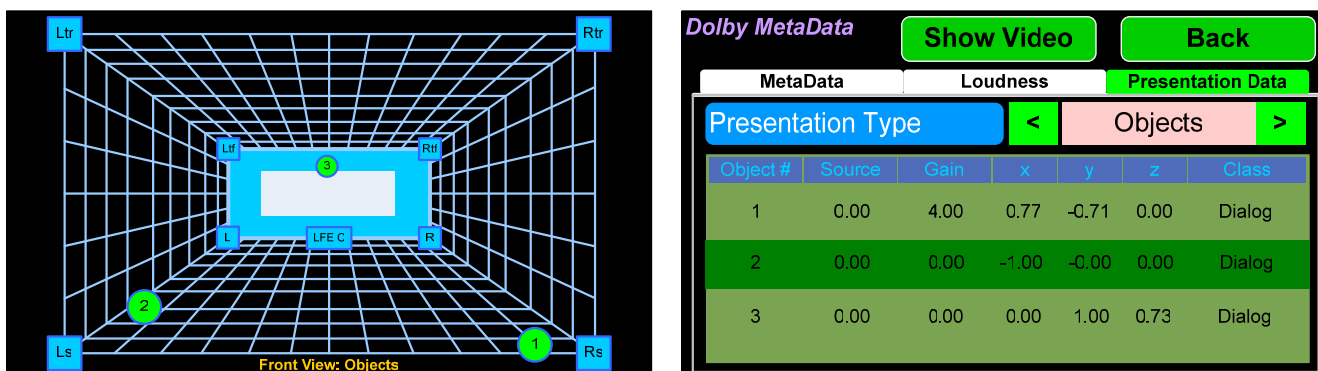

At the top center of the Dolby MetaData screen is either an **Atmos 3D** or a **Show Video** button. Touch this button to alternate between displaying the video program or the Dolby® ATMOS Visualizer screen. This screen offers views of the listening room. There are two basic 3D views of the screen, as illustrated in Figures 2.22 and 2.23, front view and top view. The **Adjust B** knob can be pressed to select between front and top views.

The Presentation Type setting in the Dolby MetaData screen is used to display relevant metadata for either audio bed or dynamic objects. Touch the arrows to change the selection. The **Adjust A** knob can also be pressed to select different Presentation Types.

Figure 2.22 – Dolby® ATMOS Visualizer Screen Front View

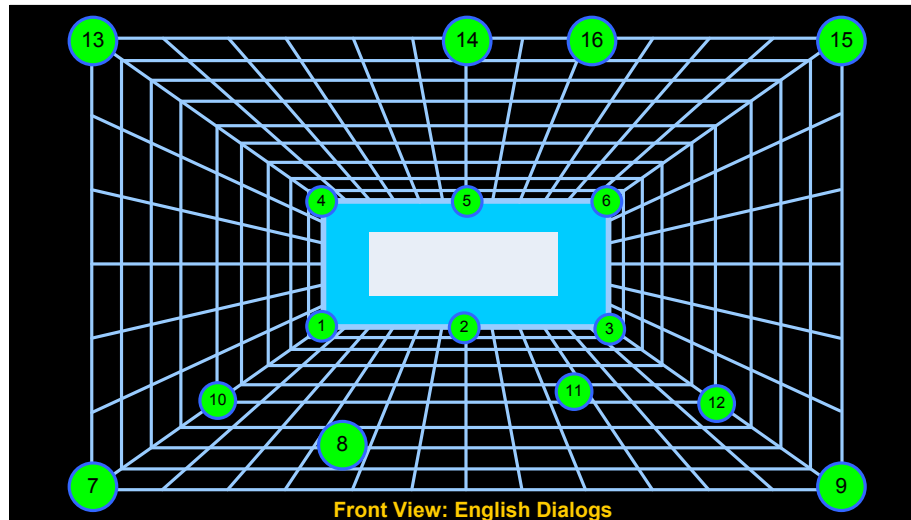

Figure 2-22 shows the listening room with a 3D front view, with a representation of the video program screen location shown in the center as a white rectangle. The various objects are shown as named audio bed objects (in blue boxes) or as numbered dynamic objects (in green circles). Dynamic objects may move around through the 3D screen as they move in the program material. These objects appear according to what is present in the Dolby® ATMOS bitstream. A maximum number of 16 objects of any type may be displayed.

Figure 2.23 – Dolby® ATMOS Visualizer Screen Top View

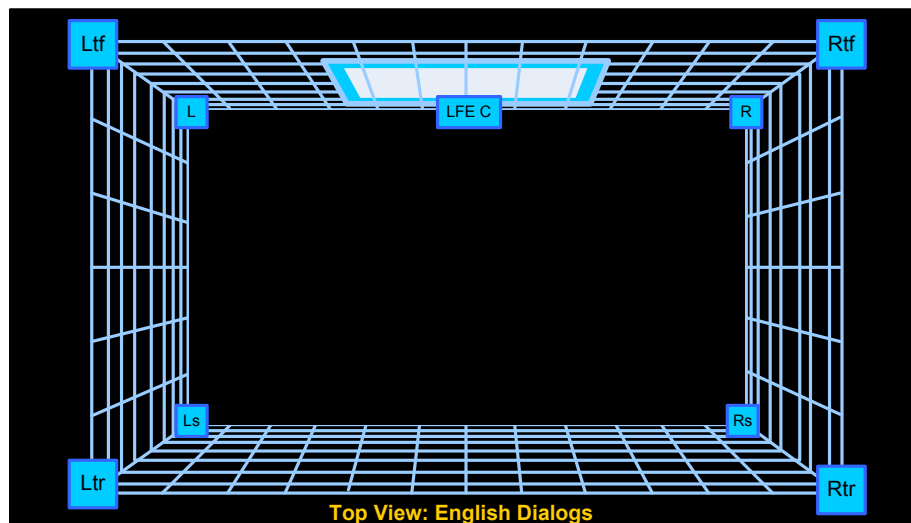
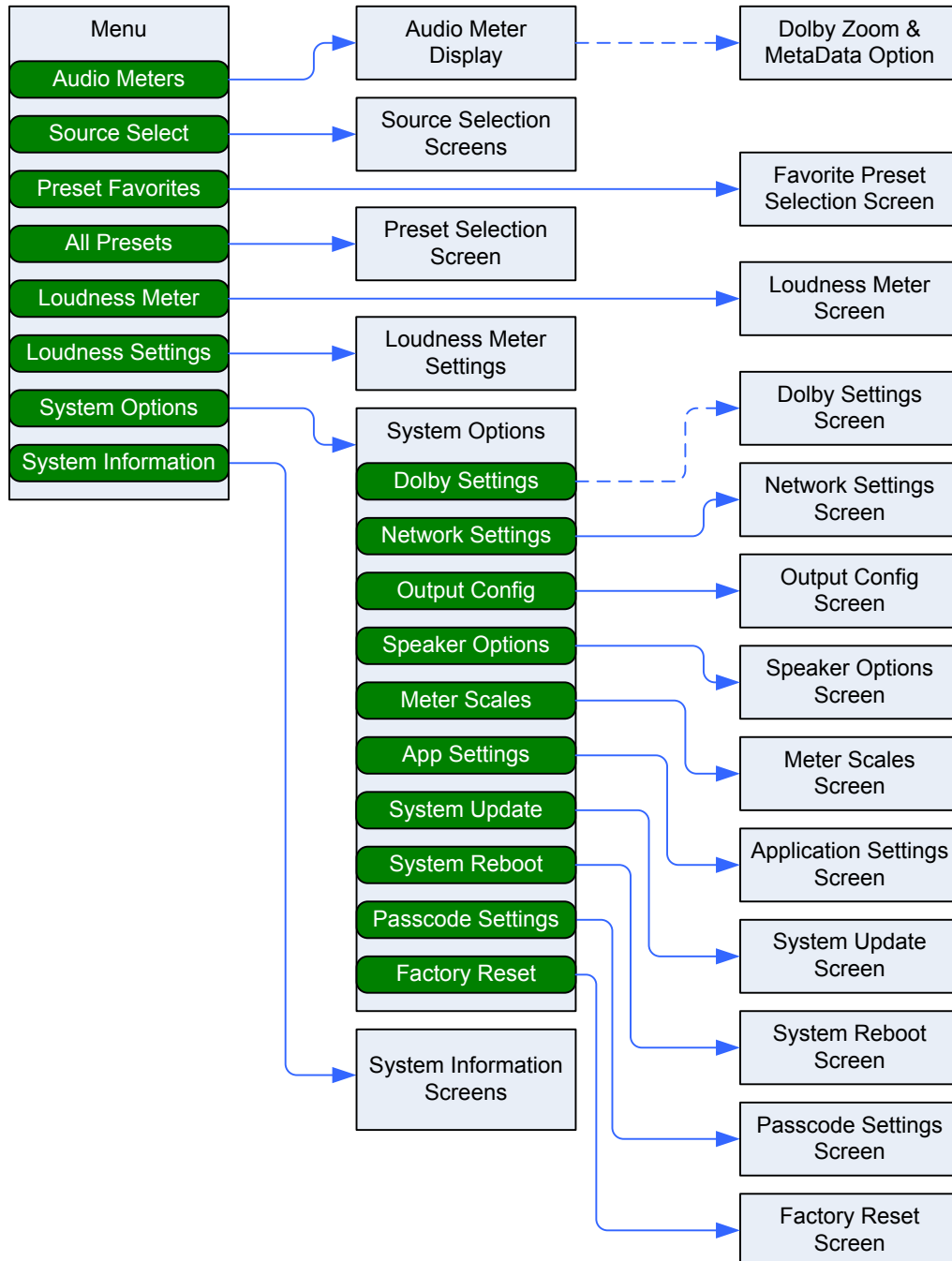

Figure 2-23 shows the listening room with a 3D top view, looking down into it with a representation of the video program screen location shown in the center top (front wall) as a white rectangle. Although Figure 2-23 is showing only audio bed objects, which are in fixed positions as speakers in the listening room, any objects can be shown, as contained in the Dolby® ATMOS stream.

Menu / Option Touchscreen

By far, most of the option settings are performed using the Web-based GUI software. However, there are a few commonly used setting and information screens that are available locally in the iAM-12G-SDI using the **Menu** which appears on the left screen. Figure 2-24 is a diagram of the menu arrangement, a tree showing how to reach any screen or menu from the **Menu**. The descriptions in this chapter follow the organization shown in the diagram, starting with Figure 2-25, which shows the **Menu**.

Figure 2-24: Menu Tree



Menu

To access the submenus, touch one of the selector buttons presented on the screen, as shown in Figure 2-25. To return to the **Audio Meters** display, touch the **Audio Meter** selector button.

Figure 2-25: Menu

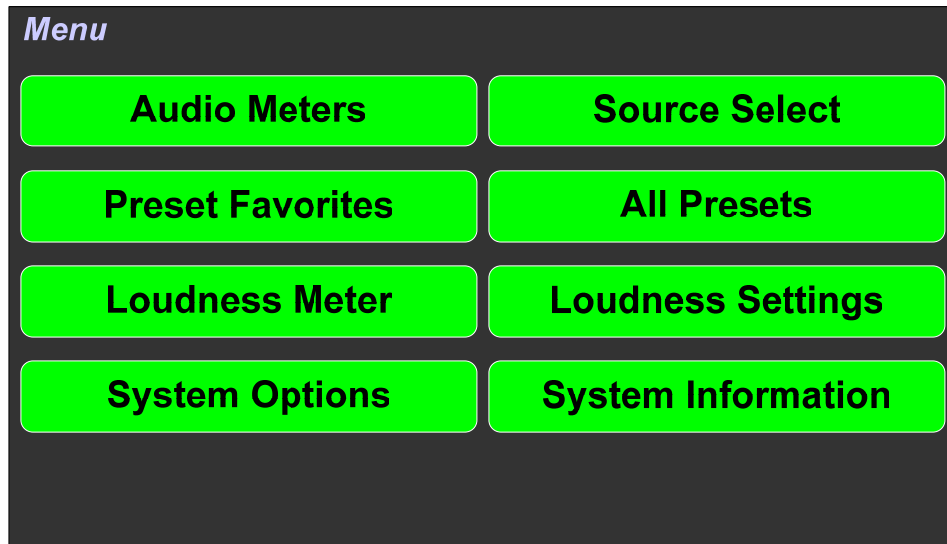

The function of each of these selector buttons is described in the following sections.

Audio Meters

Touch the **Audio Meters** button in the **Menu** to switch to the main audio metering screen. This screen is described in the **Channel Meters and Touch Operations** section of this chapter.

Source Select

Touch the **Source Select** button to display the **Source Select** screens as shown in Figure 2-26.

Figure 2-26: Source Select Screens



Using these screens, the installer can quickly determine that the sources are correctly connected and are ready for use. It allows you to directly monitor each selected source.

1. The most recently selected source is shown in light blue.
2. Sources that the iAM-12G-SDI is equipped to monitor are shown in blue.
3. Sources that the iAM-12G-SDI is capable of monitoring, but are not licensed for monitoring are shown in gray. If you would like to license additional signals, contact Wohler to purchase the source module and/or license.
4. If you select AoIP, MADI BNC, or MADI Optical, one of the screens shown in Figure 2-27 will appear to allow you to refine your choice to a set of 8 channels within the source.

Figure 2-27: Channel Select Screens:

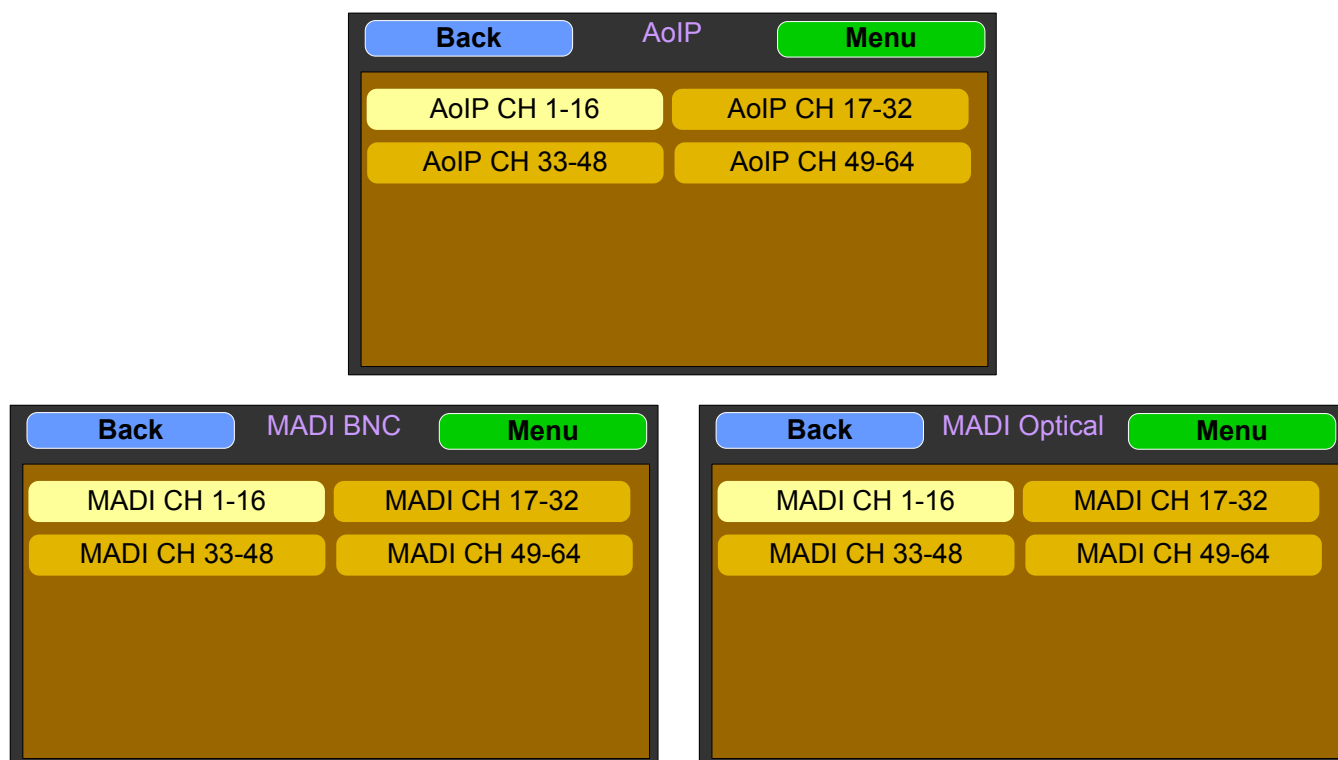

To select a source, simply touch the associated button(s). After a quick 2-second delay, the metering screen will display the channels contained in that source. The channels will be muted. Touch the channels you would like to hear on the metering screen. To exit this menu and return to the **Menu**, touch the **Menu** button.

To return to the **Source Select** screen without making a selection, touch the **Back** button. To exit this menu and return directly to the **Menu**, touch the **Menu** button.

Presets

Presets are pre-arranged input and monitoring setups that can be used to monitor a variety of combinations of inputs. They may be set up to allow quick and easy selection of monitoring configurations for various productions and situations. If you have not set up any Presets, use the **Configure Presets** page in the Web GUI to do so. Refer to Chapter 4. Or, if you prefer not to set up any Presets, simply monitor the sources directly using the **Source Select** button in the **Menu**.

Preset Favorites

Touch the **Preset Favorites** button to display the **Preset Favorites** screen. This shows the Presets that you have designated as Favorites. Refer to the Dashboard section of Chapter 4. Generally, these are frequently used Presets that you want to separate out from the possibly many other Presets in the system. The **Preset Favorites** screen is shown in Figure 2-28.

Figure 2-28: Preset Favorites Screen

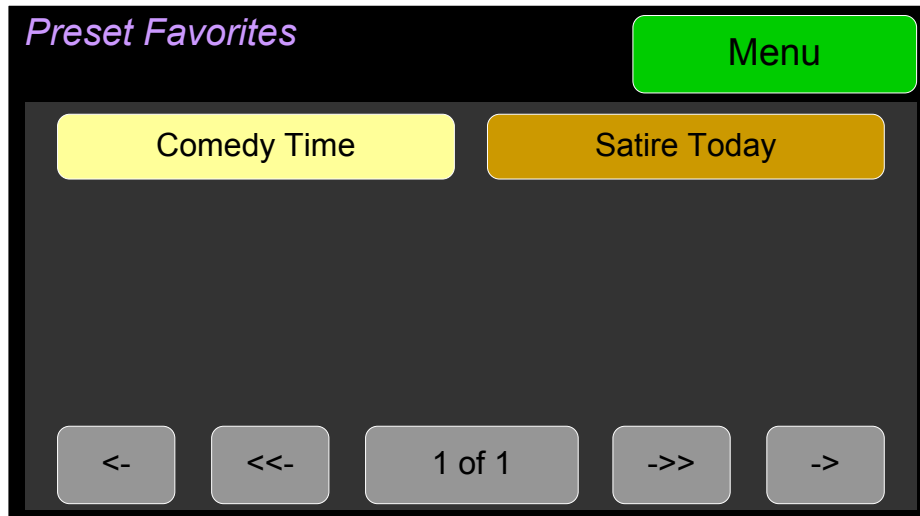

In this screen, the currently selected Preset is shown in bright yellow.

Touch any Preset to select it. To exit this screen without making a selection, touch **Menu**.

If no Favorite Presets have been designated, this screen will appear as shown in Figure 2-29.

Figure 2-29: Preset Favorites Screen – No Favorites

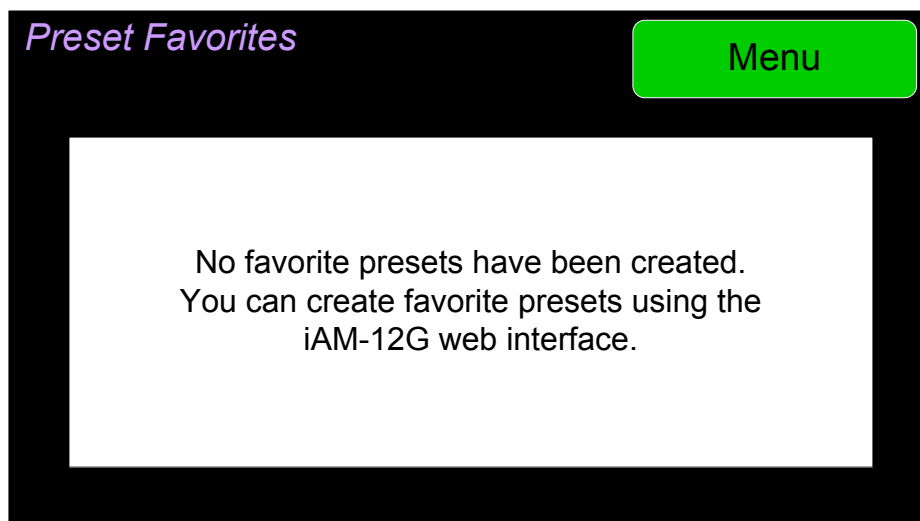

All Presets

Touch the **All Presets** button to display the **All Presets Group Selection** screen as shown in Figure 2-30. If no Presets have been created, the screen in Figure 2-32 appears instead.

Figure 2-30: All Presets Screen – Group Selection

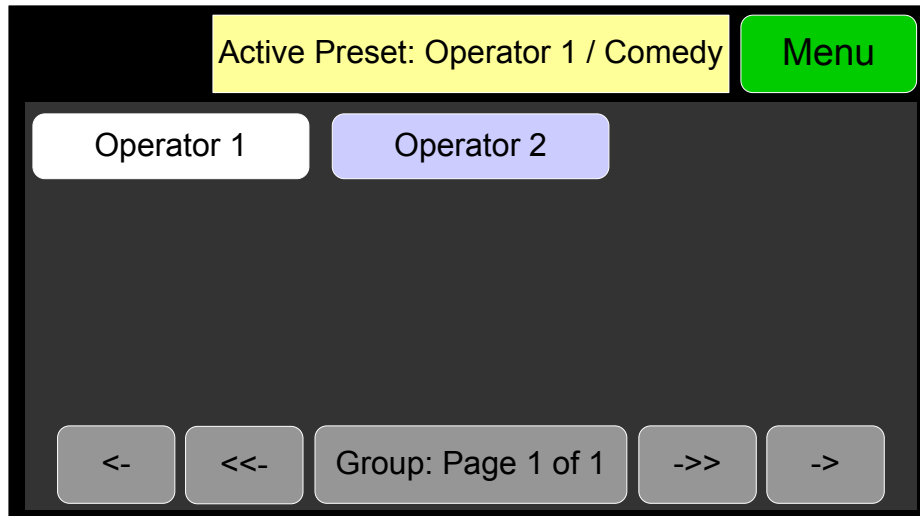

The Presets are normally arranged into Groups. Use this screen to select which Preset-containing Group to examine. After selecting one of the Groups, the **Preset Selection** screen shown in Figure 2-31 is shown.

Figure 2-31: All Presets Screen – Preset Selection

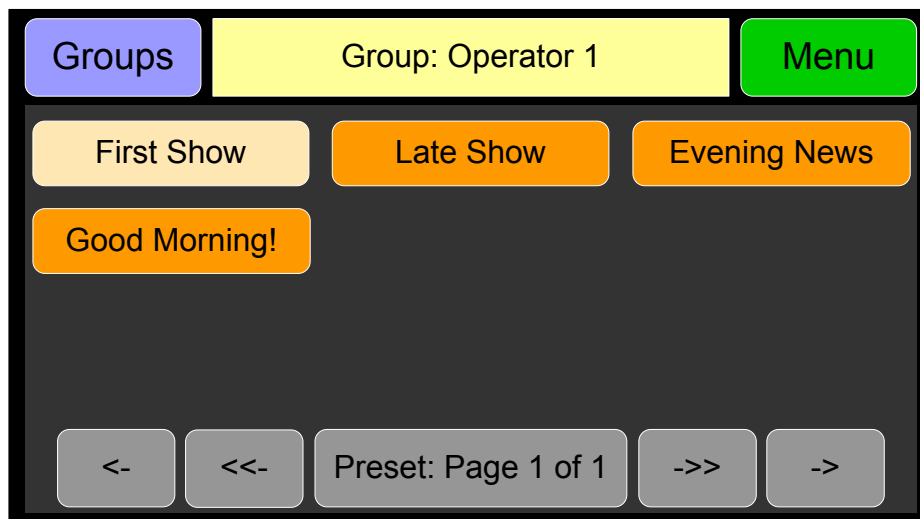

To select a Preset, touch the associated button. After a quick 2-second delay, the metering screen will display the channels contained in that source.

To return to the **All Presets Group Selection** screen instead, touch the **Groups** button. To return to the **Menu** without making a selection, touch the **Menu** button.

Figure 2-32: All Presets Screen – No Presets

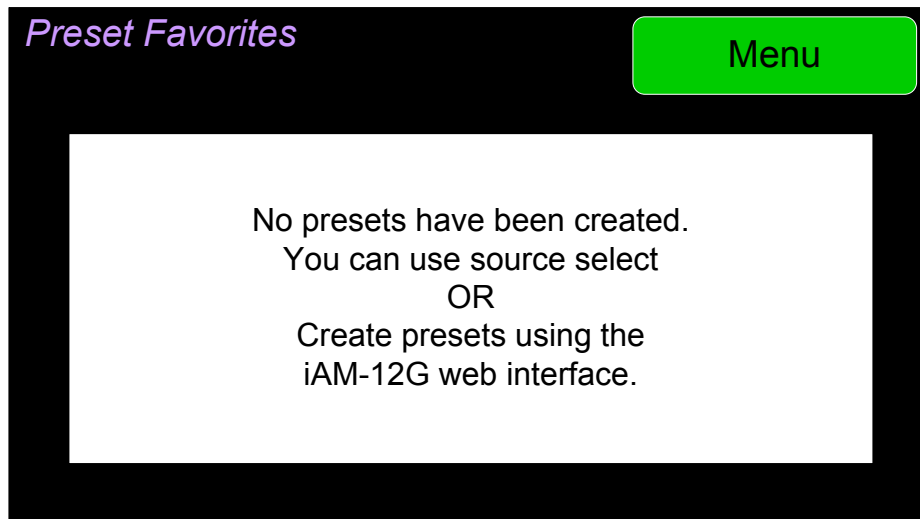

To return to the **Menu** from this screen, touch the **Menu** button.

Loudness Meter

Touch the **Loudness Meter** button to reach the **Loudness Meter Screen**. The **Loudness Meter Screen** is a more detailed view of the Loudness Measurement. It is displayed along with the channel meter screen. Touching the **Loudness Menu** button followed by the **Loudness Meter** button proceeds to the **Loudness Meter Screen**, as shown in Figure 2-33.

Figure 2-33: Loudness Meter Screen

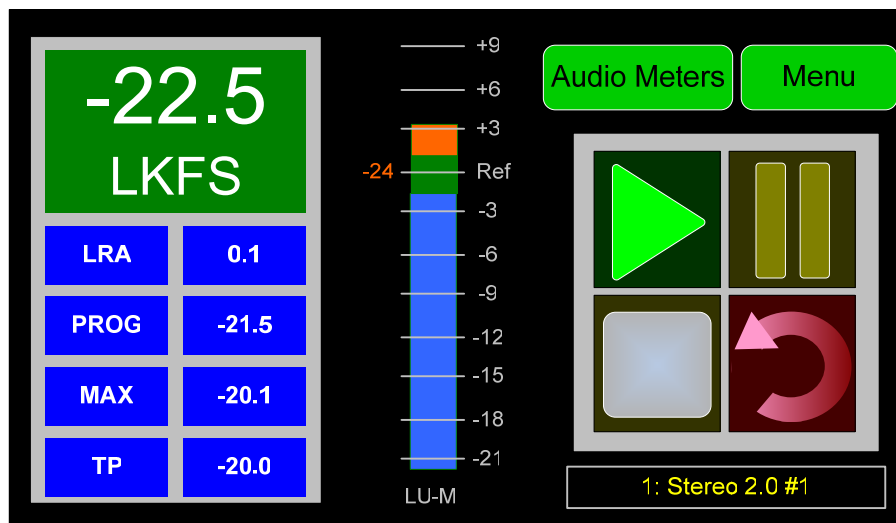

Note: In order to calculate loudness accurately, it is crucial that you correctly set the Channel Function for each channel. Depending upon the designated function of each channel, its signal levels will contribute differently to the Loudness calculation. Refer to the **Configuration | System Preference | Loudness Configuration** tab in the Web GUI.

The following data is available on the **Loudness Meter Screen**:

The Program Loudness (shown as -22.5 LKFS in the figure above) is shown digitally at the upper left of the screen as well as on the meter in the center. At the base of the meter in the center, one of three indications appears:

1. LU-M: This means that the Loudness Window is set to Momentary.
2. LU-S: This means that the Loudness Window is set to Short Term.
3. LU-C: This means that the Loudness Window is set to Custom. The Loudness Window is set in the Loudness tab in the Web GUI.

The LU Meter scale colors have the following meaning:





1. Blue: Loudness is lower than the Reference Level by the Alarm Tolerance.
2. Green: Loudness is within the Alarm Tolerance.
3. Orange: Loudness is greater than the Alarm Tolerance.

Below the digital Loudness meter, in the left column, the following parameters are also displayed:

1. The Loudness Range (LRA) is the measure of variation between the calculated loudest and softest passage over the program period (shown as LRA -0.1 above).
2. The Average Loudness is the average of all calculated loudness measurements made over the Program period (shown in gold as PROG -20.8 above).
3. The Maximum Loudness is the maximum calculated loudness over the program period (shown as MAX -20.1 above).
4. The Maximum True Peak Loudness is the absolute loudest peak waveform over the program period (shown as TP -20.0 above).

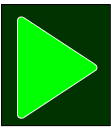
Note: Further and more detailed descriptions of all of the above Loudness terms may be found in the ITU-R BS.1770-3 loudness standard.

The controls available on the Loudness Meter Screen are:

1. **Cluster Select:** Rotate the **Adjust A** knob to select any monitored channel cluster. Changing clusters with this control will reset the loudness readings and start a new calculation on the newly selected cluster.
2. **Start:** When **Manual Mode** is selected in the Loudness Settings screen, from a stopped condition, the **Start** button will reset the gathered loudness data and begin a new reading. From a paused condition, data will not reset as monitoring is resumed. 
3. **Pause:** The **Pause** button will temporarily stop or continue gathering loudness data. Data will not be reset using this control. 
4. **Reset:** The **Reset** button will reset the gathered loudness data. If it is pressed while a loudness measurement is in progress, a new reading will then immediately begin. 
5. **Stop:** When **Manual Mode** is selected in the Loudness Settings screen, the **Stop** button will stop gathering loudness data. Data will be held for viewing and not be reset using this control. 
6. **Back:** Touching the **Back** button to go to the Loudness Menu.
7. **Audio Meters:** Touching the **Audio Meters** button will proceed to the

Audio Meters screen.

Loudness Settings

Touch the **Loudness Settings** button to display the **Loudness Settings** screen. This screen allows you to change between **Manual** and **Continuous** Monitoring Modes, and also to set the Alarm mode. It also provides a summary of various Loudness settings, as set in the **Configuration | System Preference | Loudness Configuration** tab of the Web GUI. Refer to Figure 2-34.

Figure 2-34: Loudness Settings Screen

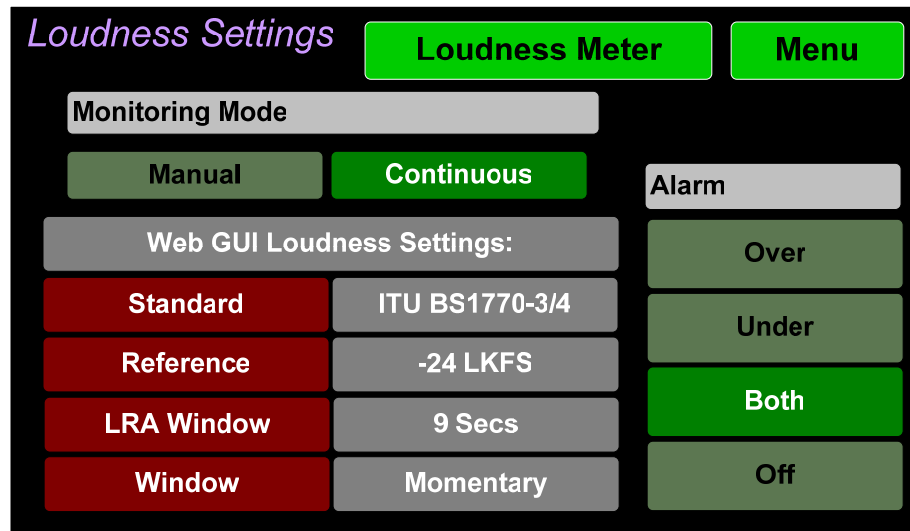

The controls and information available on the Loudness Meter Screen are:

Monitoring Mode:

1. **Manual:** Touch the **Manual** button to enable Manual Mode. This allows you to measure the loudness of a specific program or segment of a program, such as a commercial. In this mode, the **Start** and **Stop** button on the Loudness Meter screen can be manually used to begin and end a loudness measurement interval. The reading for that interval is then held on the Loudness Meter.
2. **Continuous:** Touch the **Continuous** button to enable Continuous Mode. In this mode, loudness readings are continually made. The **Stop** button on the Loudness Meter screen is not active.

Alarm:

1. **Over:** The Alarm indication will only appear when Loudness has exceeded the **Reference Level** by the **Tolerance** amount.
2. **Under:** The Alarm indication will only appear when Loudness is below the **Reference Level** by the **Tolerance** amount.
3. **Both:** The Alarm indication will only appear when Loudness has exceeded or is below the **Reference Level** by the **Tolerance** amount.
4. **Off:** The Alarm indication will not appear.

Web GUI Loudness Settings: These settings are included on this screen for reference only. They cannot be changed on this screen.

1. **Standard:** This is the loudness standard by which the loudness calculation is made.
2. **Reference:** This is the set point in the loudness measurement about which the determination is made as to whether an alarm should be displayed.
3. **LRA Window:** This is a moving window of time over which the loudness measurement is made.
4. **Window:** This may be set to **Momentary**, **Short**, or one of 22 values, ranging from one second to two hours.

Note: Further and more detailed descriptions of all of the above Loudness terms may be found in the ITU-R BS.1770-3 loudness standard.

When you have completed reviewing or changing the settings, touch the **Loudness Meters** button to go the **Loudness Meters** screen, or touch the **Back** button to return to the **Loudness** menu

System Options

Touch the **System Options** button in the **Menu** to display the five choices for setting some system options locally. The **System Options Menu** is shown in Figure 2-35.

Figure 2-35: System Options Menu

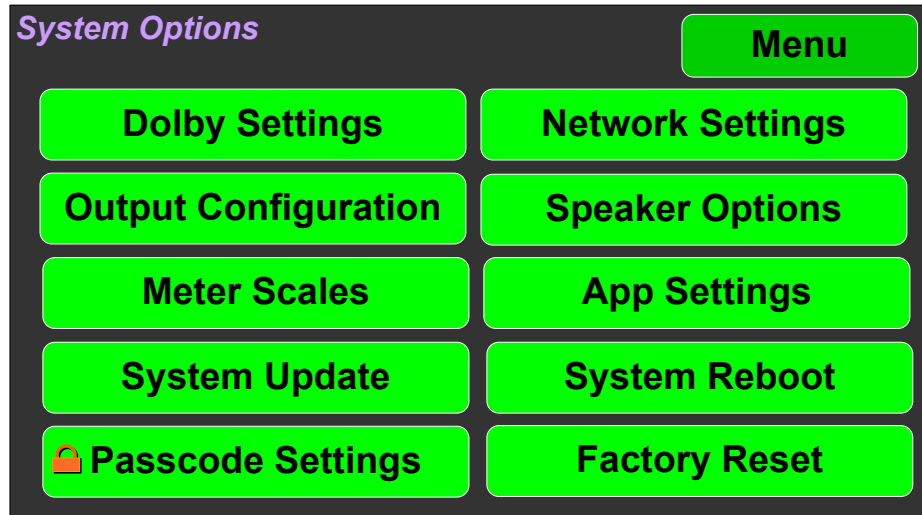

The options are:

1. Dolby Settings
2. Network Settings
3. Output Configuration
4. Speaker Options
5. Meter Scales

6. App Settings
7. System Update
8. System Reboot
9. Factory Reset

The menus associated with these options are described in the following nine sections.

Dolby Settings

Touch the **Dolby Settings** button to proceed to the **Dolby Settings Screen**.

Dolby Settings Screen: Decoder Tab

Dolby Settings Screen contains four tabs, each containing a number of option settings. Figure 2-36 shows the **Decoder** tab.

Figure 2-36: Dolby Settings: Decoder Tab

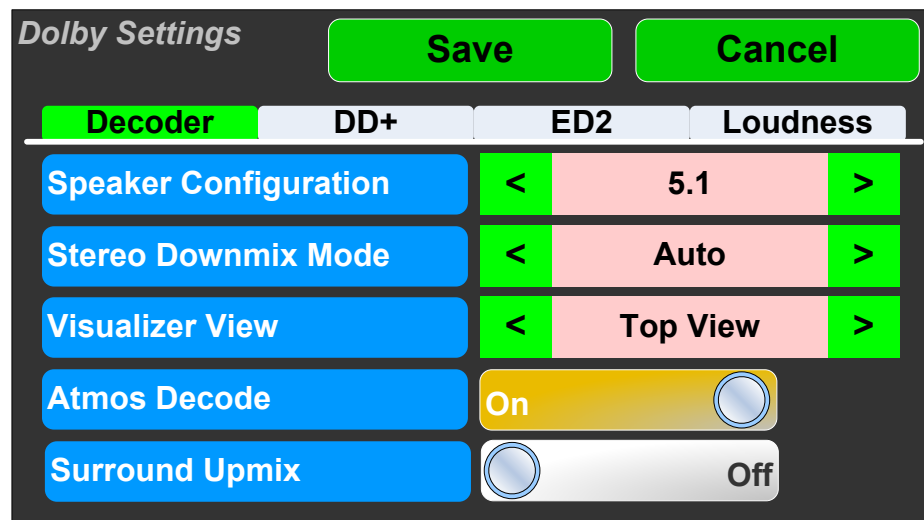

1. **Speaker Configuration:** This setting defines the output speaker configuration in a range from 2.0 to 7.1.4. This setting is reflected in channel descriptions of the audio level meters. Select an option from the list by touching the **Left** (<) and **Right** (>) buttons. Speakers that receive no content from the input source are silent.
2. **Stereo Downmix Mode:** This setting provides a choice between Auto, LtRt, or LoRo downmix modes. Select an option from the list by touching the **Left** (<) and **Right** (>) buttons.
3. **Visualizer View:** The iAM-12G-SDI, when equipped with a valid Dolby Atmos license, provides the ability to view the various objects in a 3D space. There are two views available, a Top View or a Front View.
4. **Atmos Decode:** This setting applies Dolby Digital Plus and ED2 (ED2: Dolby E + Evolution) bitstreams only. (If the optional Dolby Atmos license is not contained in the iAM-12G-SDI, then this option will always be set to the **Off** position. Contact Wohler Sales to obtain this license.) Set the **Dolby Atmos**

Decode touch switch to **On** to enable Dolby Atmos content decoding. Set the touch switch to **Off** to disable Dolby Atmos content decoding. Dolby Digital Plus with Dolby Atmos content is then decoded as Dolby Digital Plus. When **Atmos Decode** is set to **Off**, then on the Dolby MetaData screen the **Atmos 3D** or **Show Video** buttons do not display.

5. **Dolby Surround Upmix:** The Dolby Surround Upmix option upmixes channel-based content, but does not apply to audio objects. This setting applies to Dolby Digital Plus bitstreams only. To enable Dolby Surround Upmix, the **Dolby Atmos Decode** option must be turned **On**. Set the **Dolby Surround Upmix** touch switch to **On** to enable the Dolby Surround Upmix option. Set the touch switch to **Off** to disable the Dolby Surround Upmix option.

Dolby Settings Screen: DD+ Tab

Figure 2-37 shows the option settings on the **DD+** tab.

Figure 2-37: Dolby Settings: DD+ Tab, Line Mode

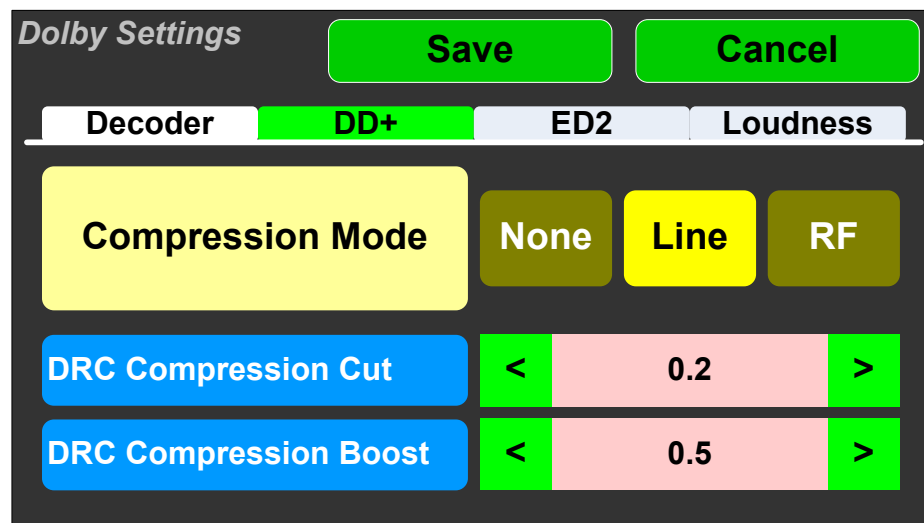

1. **Compression Mode:** Setting a compression mode is not required. If you do not need or want to set the mode, leave the default selection as **Line**. Otherwise, select the **Line** or **RF** mode as appropriate to your decoding requirements.
2. **DRC Compression Cut:** This option is used only when the **Compression Mode** is set to **Line**. 1.0 is equivalent to 100% Dynamic Range Control Compression Cut Rate and each 0.1 is equivalent to 10%. Set the DRC Compression Cut Rate in the range of 0 to 1, in increments of 0.1. Select an option from the list by touching the **Left (<)** and **Right (>)** buttons. The default setting is 0.
3. **DRC Compression Boost:** This option is used only when the **Compression Mode** is set to **Line**. 1.0 is equivalent to 100% Dynamic Range Control Compression Boost Rate and each 0.1 is equivalent to 10%. Set the DRC Compression Boost Rate in the range of 0 to 1, in increments of 0.1. Select an option from the list by touching the **Left (<)** and **Right (>)** buttons. The default setting is 0.

If the **Compression Mode** is set to either **None** or **RF**, then the **DRC**

Compression Cut and **Boost** controls cannot be adjusted and the screen appears as shown in Figure 2.38.

Figure 2-38: Dolby Settings: DD+ Tab, None or RF Mode



Dolby Settings Screen: ED2 Tab

Figure 2-39 shows the option settings on the **ED2** tab.

Figure 2-39: Dolby Settings: ED2 Tab



1. **Audio Presentation:** This option is used only when the Dolby ED2 is present. ED2 supports multiple presentations. This screen allows you to determine which presentation is used as default when in Wohler Zoom mode. Set the **Audio Presentation** in the range of 1 to 16. If you select a presentation that does not exist in the stream, it will default to Presentation 1. Select a program from the list by touching the **Left (<)** and **Right (>)** buttons. The default setting is 1.

Dolby Settings Screen: Loudness Tab

Figure 2-40 shows the option settings on the **Loudness** tab.

Figure 2-40: Dolby Settings: Loudness Tab

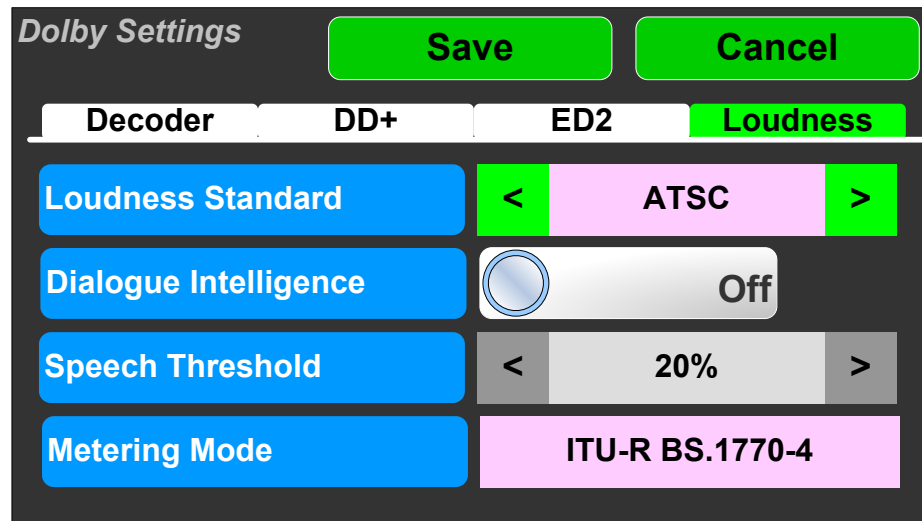

1. **Loudness Standard:** Loudness Standards vary in broadcasting throughout the world. Select the Loudness Standard from the list by touching the **Left** (<) and **Right** (>) buttons. The available standards are:
 - a. **ATSC:** For broadcasts originating in North America
 - b. **ARIB:** For broadcasts originating in Japan
 - c. **EBU R128:** For broadcasts originating in Europe
 - d. **Free TV:** For broadcasts originating in Australia
2. **Dialogue Intelligence:** Select **On** to apply Dolby Dialogue Intelligence, if applicable, for the broadcast stream.
3. **Speech Threshold:** Set the Loudness Speech Threshold to any setting between 1 and 100 percent. Select an option from the list by touching the **Left** (<) and **Right** (>) buttons. The default setting is 20 percent.
4. **Metering Mode:** This shows the metering mode that was automatically chosen based upon the Loudness standard. Either of the following will be displayed:
 - a. ITU-R BS.1770-4
 - b. ITU-R BS.1770-4 plus Dialogue Intelligence

Network Settings

Touch the **Network Settings** button in the **System Options Menu** to display the **Network Settings** menu as shown in Figure 2-41. This screen lets you view or change the product IP, the Net Mask, and the Gateway. It also lets you switch between a static (fixed) or a dynamic (DHCP) network address.

Figure 2-41: Network Settings Menu

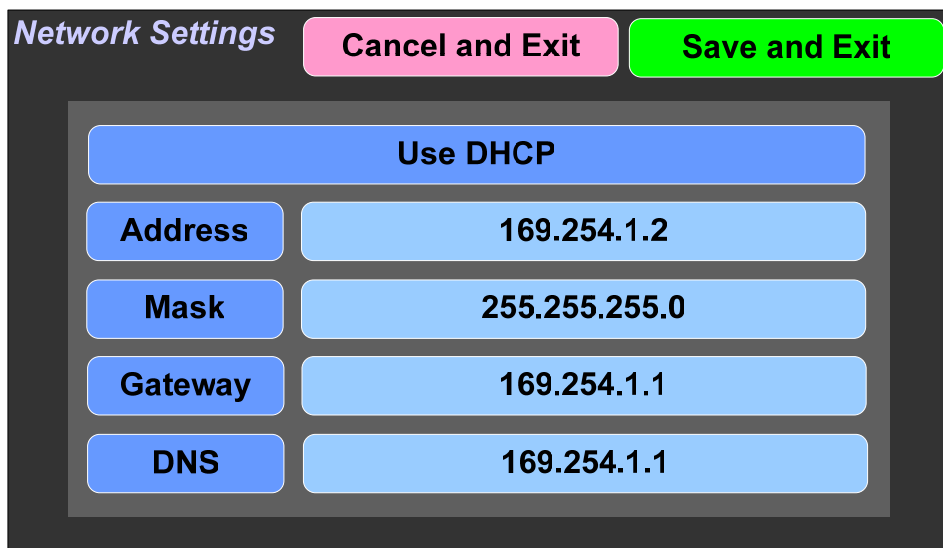

Network Settings	
Cancel and Exit Save and Exit	
Use DHCP	
Address	169.254.1.2
Mask	255.255.255.0
Gateway	169.254.1.1
DNS	169.254.1.1

1. To change the IP Address, Net Mask, Gateway, or DNS, tap the address you would like to change. A keypad will appear, as shown in Figure 2-42.

Figure 2-42: Network Settings: Address Change



Address		169.254.1.2	
1	2	3	Backspace
4	5	6	Clear
7	8	9	Cancel
255	0	.	Enter

2. Touch the digits to be entered, including the decimal points. Touch **Clear** to erase the address so that you can type a new one. Touch the **Backspace** button to correct an individual mistyped digit. Touch the **Cancel** button to

cancel the address change operation and return to the **Network Settings** screen.

3. When the address is typed, touch the **Enter** button. This will return to the **Network Settings** screen and the changed address can be seen.

To change from a static (fixed) to a dynamic (DHCP) network address, touch the **DHCP** button. The screen will change, as shown in Figure 2-43. To change back to a static (fixed) network address, touch the **DHCP** button again. The screen depicted in Figure 2-41 will reappear.

Figure 2-43: Network Settings: DHCP

The screenshot shows the 'Network Settings' screen. At the top left is the title 'Network Settings'. To its right are two buttons: 'Cancel and Exit' (pink) and 'Save and Exit' (green). Below these is a large yellow button labeled 'Use DHCP'. Underneath the yellow button is a table with four rows, each representing a network parameter and its value:

Address	169.254.1.2
Mask	255.255.255.0
Gateway	169.254.1.1
DNS	169.254.1.1

1. To complete the network addressing scheme change, touch the **Save and Exit** button. This will return to the **Menu**.
2. To abandon the changes you made, touch the **Cancel and Exit** button. This will return to the **Menu**.

Output Configuration

Touching the **Output Configuration** button in the **System Options Menu** displays the **Output Configuration** screen. Contained in this menu is an **Analog Output Reference** as illustrated in Figure 2-44. The parameters set on this tab pertain to the DB25 and XLR connectors on the rear panel of the iAM-12G-SDI.

Figure 2-44: Analog Output Reference

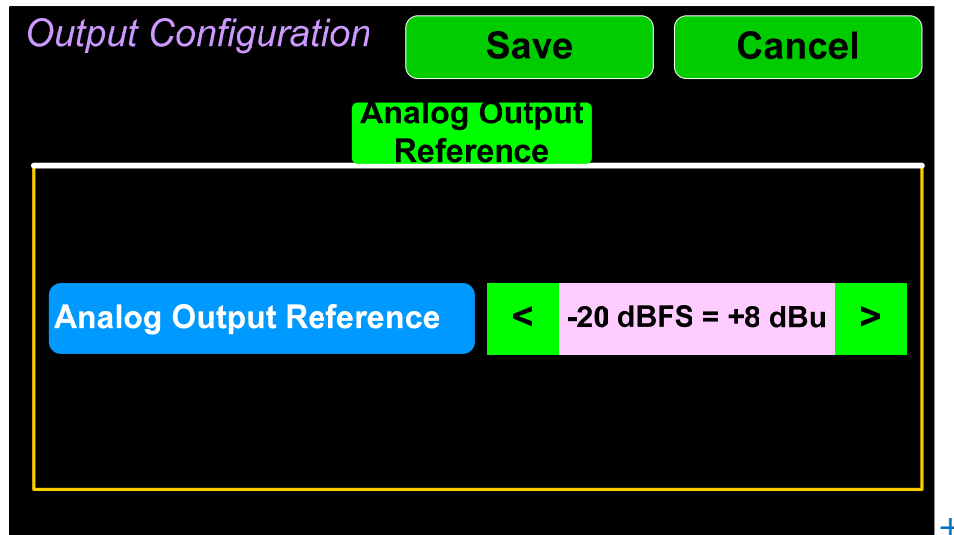

There is only one setting on the **Analog Output Reference** tab:

1. **Analog Output Reference:** This setting adjusts the relationship between the monitored digital signal level and the analog signal level that is output from both of the DB25 and both of the XLR connectors on the back panel. The default setting is -20 Dbfs = +8 dBu as shown in Figure 2-44. The range of possible settings is as follows:
 - a. -22 Dbfs = +4 dBu
 - b. -20 Dbfs = +4 dBu
 - c. -18 Dbfs = +4 dBu
 - d. -16 Dbfs = +4 dBu
 - e. -20 Dbfs = +8 dBu
 - f. -20 Dbfs = 0 dBu
 - g. -18 Dbfs = 0 dBu
 - h. -8 Dbfs = 0 dBu
 - i. 0 Dbfs = +15 dBu

Touching **Save** will save any changes made, or touching **Cancel** will return you to the **System Options** menu without saving.

Speaker Options

Touching the **Speaker Options** button on the **System Options Menu** displays the **Speaker Options** screen as shown in Figure 2-45. The controls on this screen affect various characteristics of the monitored audio as heard on the iAM-12G-SDI.

Figure 2-45: Speaker Options



The controls function as follows:

1. **Volume Reference:** The **Volume Reference** setting controls the attenuation level of the internal speakers. The value ranges from 0 to -255 dB. 0 results in full volume and -255 causes the speakers to be muted.
2. **Low Cut:** **Low Cut** is provided for cases where unusually deep content produces audible distortion and interferes with monitoring.
3. **Treble:** This tone control adjusts the high frequency speaker audio response from -12 Db to +12 Db. Lowering **Treble** compensates for high frequency pre-emphasis or removes sibilance effects. Increasing **Treble** will add "sizzle" to the sound and bring high-pitched sounds out of the mix. The control can be touched and moved left or right to adjust in 1 Db increments. Alternatively, after touching the control, the **Adjust B** knob can be used to more critically adjust the setting.
4. **Bass:** This tone control adjusts the low frequency speaker audio response from -12 Db to +12 Db. Lowering **Bass** will unmask midrange band sounds, while increasing **Bass** will make the sound "fatter". The control can be touched and moved left or right to adjust in 1 Db increments. Alternatively, after touching the control, the **Adjust B** knob can be used to more critically adjust the setting.
5. **Set to Flat:** This button sets both the **Treble** and **Bass** controls to 0 Db, removing any emphasis or de-emphasis they can provide. Selecting **Flat** provides the flattest measured response from the internal speakers.

Touch **Back** to exit this screen.

Meter Scales

Touching the **Meter Scales** button on the **System Options Menu** displays the **Meter Scales** screen as shown in Figure 2-46. The controls on this screen select the scale standards as well as the ballistics that will be applied to the audio meters.

Figure 2-46: Meter Scales Screen

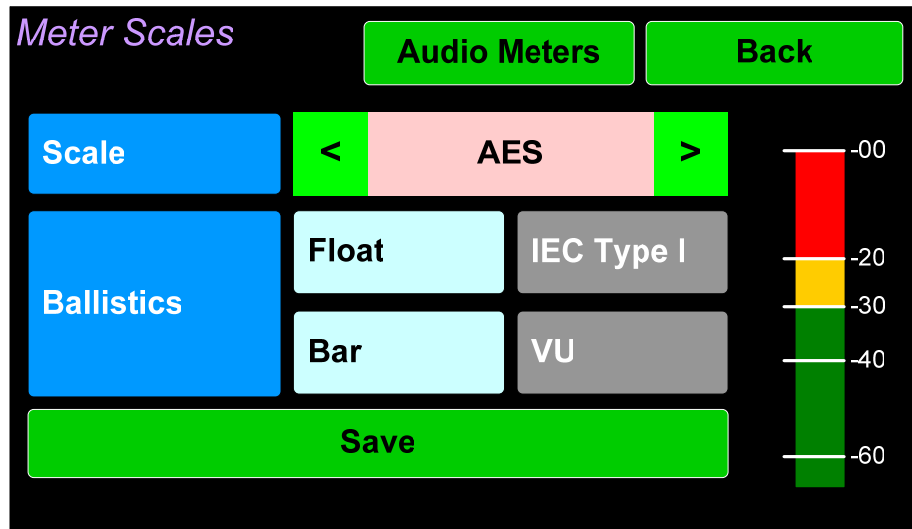

The controls function as follows:

1. **Scale:** This meter scales standard to be used when displaying audio levels. A choice of seven scales is available. Use the left and right arrows to select the scale. A representation of the chosen scale will be shown at the right. The possible scales that can be used are shown in Figure 2-47.

Figure 2-47: Meter Scale Selection

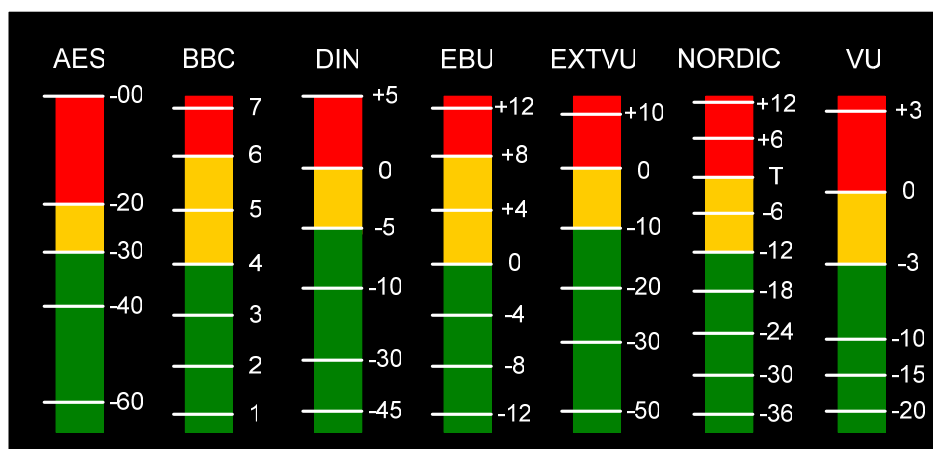

Table 2-4: Meter Limits and References

Scale	Bottom Limit	Top Limit	Default Reference	Default Color Bounds		Default Ballistics	
				Lower	Upper	Float	Bar
AES	-72 Dbfs	0.0 Dbfs	0 Dbfs = 0 Dbfs	-30 Dbfs	-20 Dbfs	IEC Type I	VU
BBC	-13.25 dBr	+13.0 dBr	-18 Dbfs = 0 dBr	0 dBr	8 dBr	—	IEC Type I
DIN	-53 dBr	+5.5 dBr	-15 Dbfs = 0 dBr	-5 dBr	0 dBr	—	IEC Type I
EBU	-13.25 dBr	+13.0 dBr	-18 Dbfs = 0 dBr	0 dBr	8 dBr	—	IEC Type I
EXTVU	-56 dBr	+16.0 dBr	-20 Dbfs = 0 dBr	-10 dBr	0 dBr	—	VU
NORDIC	-44 dBr	+12.5 dBr	-18 Dbfs = 0 dBr	-10 dBr	0 dBr	—	IEC Type I
VU	-45 dBr	+3.5 dBr	-20 Dbfs = 0 dBr	-3 dBr	0 dBr	—	VU

2. **Ballistics:** The Bar and Float ballistics associated with the selected meter scale are displayed. Refer to Table 2-5. Ballistic timings are valid only at 48 kHz.

Table 2-5: Meter Timings

Ballistics	Rise	Fall	
		Level Change	Time
VU	Not Specified		
IEC Type I	5 ms to reach -2 Db of settled reading	-20 Db	1.7 sec.
IEC Type II	10 ms to reach -2 Db of settled reading	-24 Db	2.8 sec.
None	Bar or Floating Segment Not Displayed		

When you have made your choices, touch **Save** to retain them. Touch **Back** or **Audio Meters** to exit this screen.

App Settings

Touching the **App Settings** button in the **System Options Menu** displays the **Application Settings** screen as shown in Figure 2-48.

Figure 2-48: Application Settings

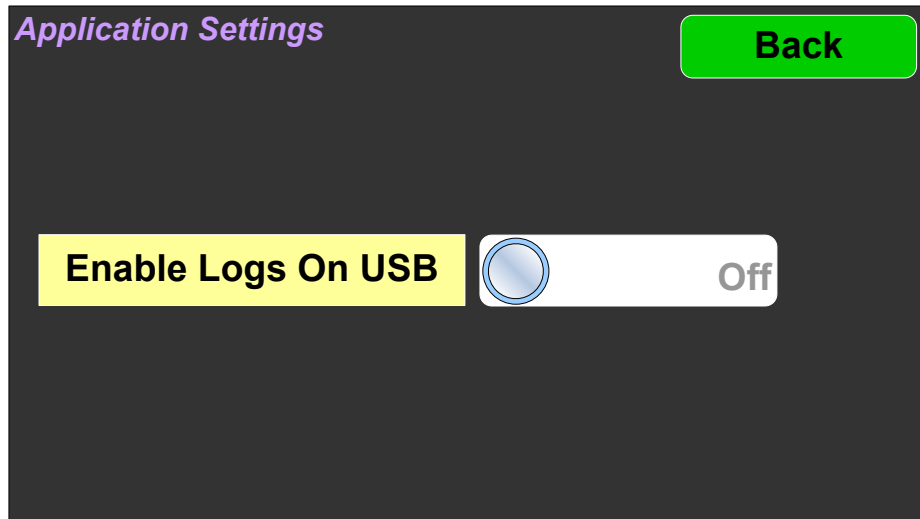

There is one setting:

1. **Enable Logs On USB:** When this setting is turned On, records of internal actions and events within the iAM-12G-SDI are recorded onto a flash drive inserted into the USB connection on the front panel. This feature would generally be used under advice from Wohler Technical Service.

Touching **Back** will return you to the **System Options** menu.

System Software Update

Touching the **System Update** button in the **System Options Menu** displays the **Software Update** screen as shown in Figure 2-49. Refer to Appendix A for complete instructions to perform a software update.

The **System Update** function should be used with a bit of caution. It puts the system out of service for at least 5 minutes while it is updating and later rebooting.

Figure 2-49: Software Update

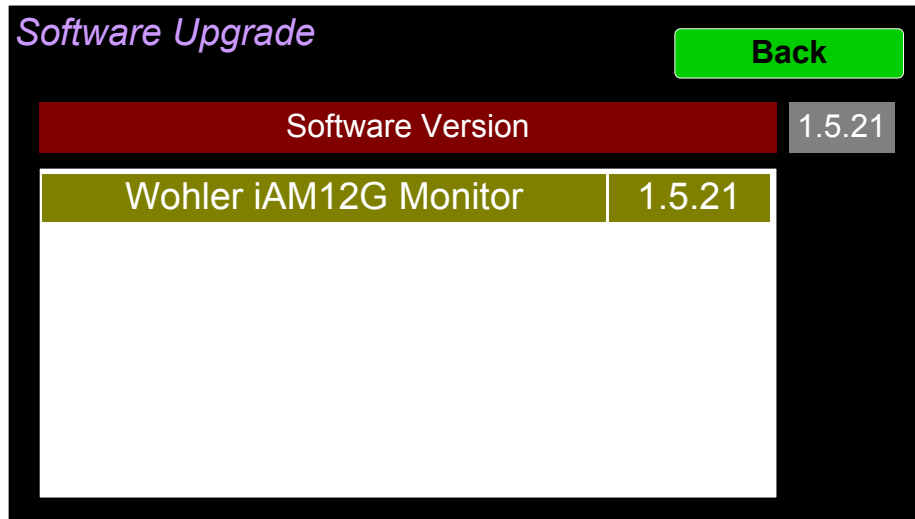

If you have any doubt as to whether you should press **Yes**, press **Back** instead, and contact Wohler Technical Service for advice. Pressing **Back** will return you to the **System Options** menu.

System Reboot

Touching the **System Reboot** button in the **System Options Menu** displays the **System Reboot** screen as shown in Figure 2-50. This function is normally only used upon request from Wohler Technical Service to troubleshoot or correct an issue.

The **System Reboot** function should be used with a bit of caution. It puts the system out of service for several minutes while it is rebooting.

Figure 2-50: System Reboot

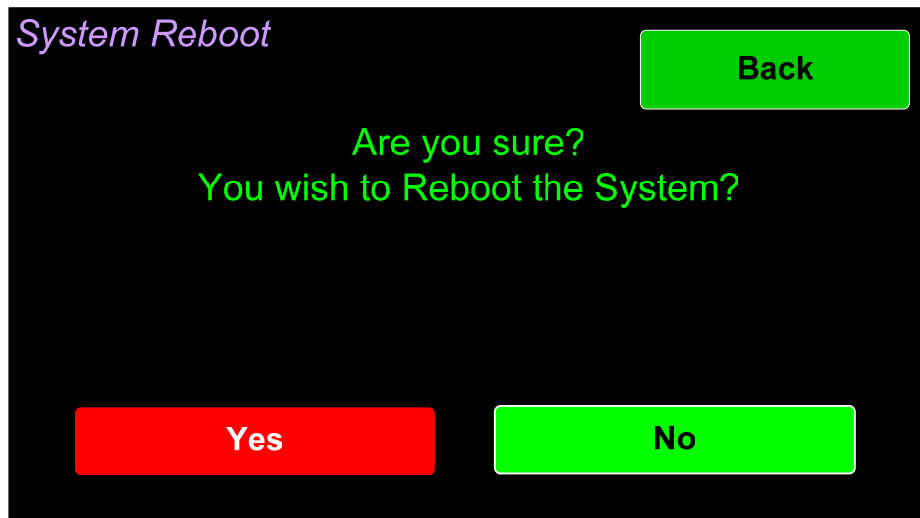

If you have any doubt as to whether you should press **Yes**, press **Back** or **No** instead, and contact Wohler Technical Service for advice. Pressing **Back** or **No** will return you to the **System Options** menu.

Factory Reset

Touching the **Factory Reset** button in the **System Options Menu** displays the **Factory Reset** screen as shown in Figure 2-51. Because of the large change this function is about to make to the product, it asks for you for verification that you really want to proceed.

The **Factory Reset** function should be used with caution. It deletes all of the settings you have programmed into the system. It returns the system to the way it was when received new from the factory.

Figure 2-51: Factory Reset

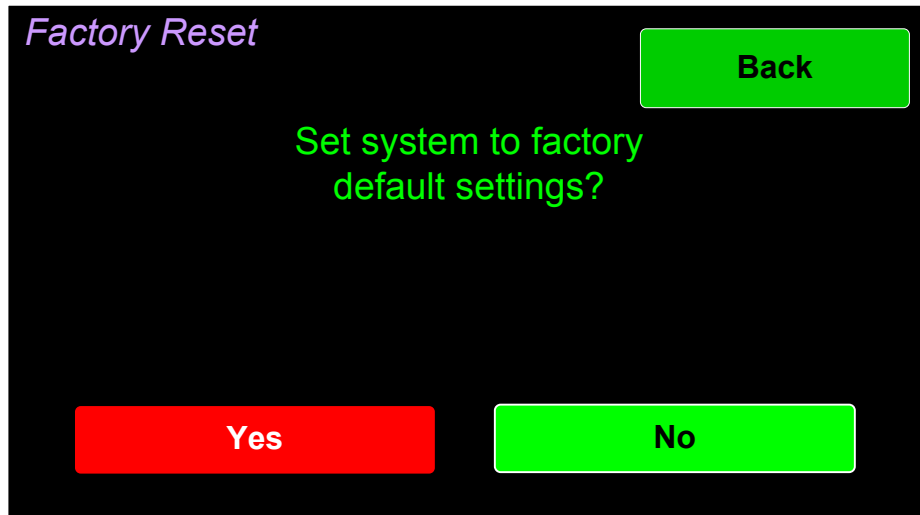

Note: **Factory Reset** will also reset your IP address to the default one.

After a Factory Reset, the IP Settings will need to be updated. The default IP address for the unit is determined based upon the Mac address. It is 169.254.1.xx where xx is the last octet of the management Mac address. For example, if the Mac address is b4:ed:54:d0:04:28 then the IP address would be 169.254.1.40 (40 is the decimal equivalent for the last octet of Mac address 28.)

If you have any doubt as to whether you should press **Yes**, press **Back** or **No** instead, and contact Wohler Technical Service for advice. Pressing **Back** or **No** will return you to the **System Options** menu.

System Information

Touching the **System Information** button in the **Menu** displays the **System Information** screen as shown in Figure 2-52. This is a tabbed screen that will let you view various system data, as well as data for any options that are part of the system. The information shown on these screens is read only and cannot be changed.

Figure 2-52: System Information Screen – System Tab

System Information	
Menu	
System	919469
919464	
System State	Valid
System IP Address	169.254.1.40
Software	1.3.1
Serial Number	000000
MAC Address	b4:ed:54:d0:04:28

Additional data shown on other tabs is shown in Figures 2-53, 2-54 and 2-55. Simply touch a tab to show its data. The number of tabs will vary according to how the product is equipped with options and features. Touch the **Menu** button return to the **Menu**.

Figure 2-53: System Information Screen – 919469 Tab

System Information	
Menu	
System	919469
919464	
Type	Option
State	Valid
Version	1.3.1
Hardware Revision	B.2
Upgraded for Revision	B.2

Figure 2-54: System Information Screen – 919464 Tab

System Information **Menu**

System	919469	919464
---------------	--------	---------------

Type	Mainboard
State	Valid
Version	1.3.1
Hardware Revision	B.2
Upgraded for Revision	B.2

Figure 2-55: System Information Screen – 919475 Tab

System Information **Menu**

System	919469	919464	919475
---------------	--------	--------	---------------

Type	AoIPOption
State	Valid
Version	1.7.33
Hardware Revision	A.0
Upgraded for Revision	.

Passcode Settings

To prevent accidental or unauthorized changing of critical settings in some of the menus, it is possible to block or restrict access to various menus. The Wohler Web GUI can be used to limit access to the menus of your choice. Refer to Chapter 4, the **Front Panel Configuration** tab of **System Preferences**.

The iAM-12G-SDI contains a **Passcode Settings** screen. Access to this screen is always protected by a unique Passcode, which you can set. Note that the protection of the **Passcode Settings** selection is indicated by an orange lock icon:  The **Passcode Settings** button on the **System Options** screen contains this icon, as shown in Figure 2-56. The factory default Passcode is 0-0-0-0.

Figure 2-56: System Options – Passcode Settings Lock



Touching the **Passcode Settings** selection in the **System Options** menu proceeds to the **Passcode Entry** screen as shown in the left image of Figure 2-57.

Figure 2-57: Passcode Entry Screen

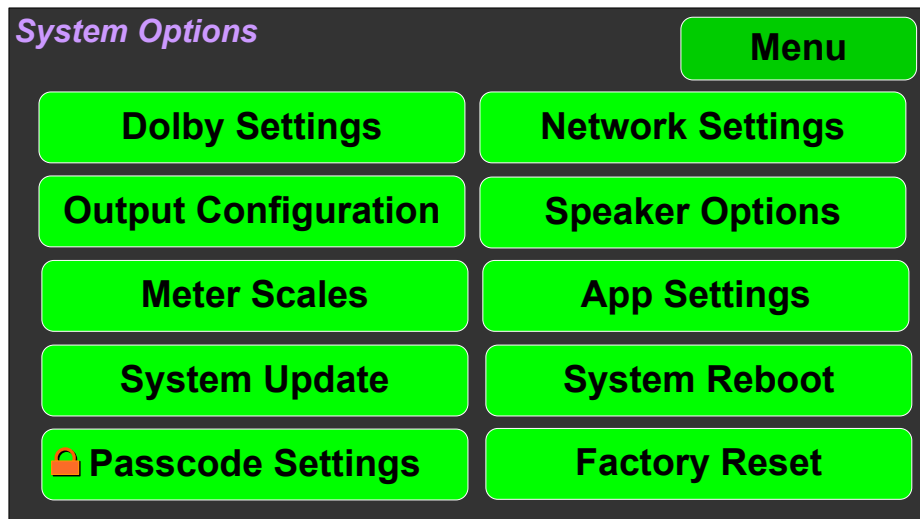
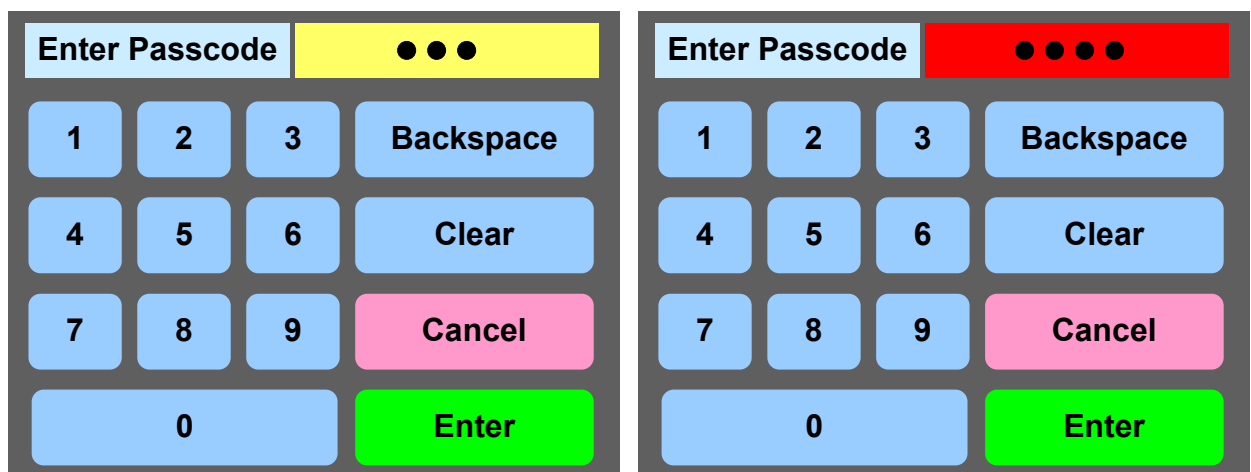

Enter the Passcode on the keypad and touch **Enter**. The numbers will display as

bullets in the field. If you enter the wrong Passcode, the entry field will turn red, as shown on the right image of Figure 2-57. Press **Clear** and try again.

When you have successfully entered the Passcode, the Passcode Settings screen will appear, as shown in Figure 2-58.

Figure 2-58: Passcode Settings Screen

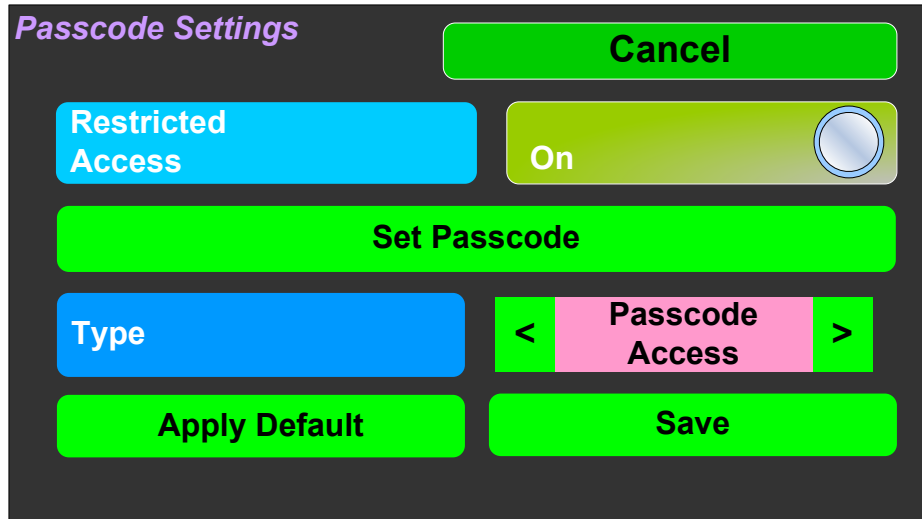

The functions on this screen are as follows:

Restricted Access: This switch will turn ON or OFF protection or blocking of any menus, except for the Passcode Settings menu, which is always Passcode protected.

Set Passcode: Touching this button proceeds to a keypad which allows you to enter a new Passcode. The screen shown in Figure 2-59 will appear. The Passcode can be any 4-digit number. Touch **Enter** to save the new Passcode or touch **Cancel** to keep the previous Passcode. Be sure to save the Passcode in a safe place for future reference.

Figure 2-59: Set Passcode Screen

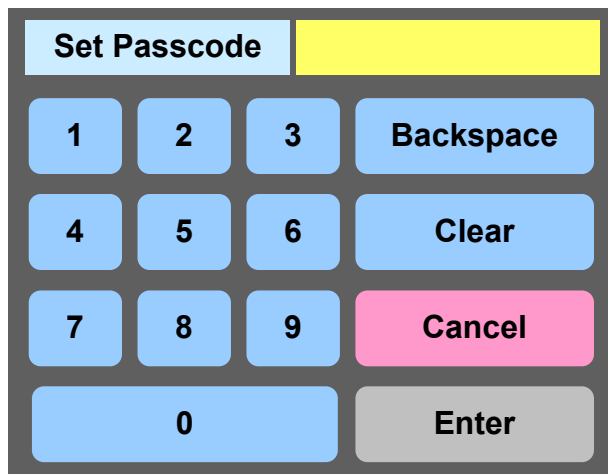

Type: Select the type of disabled button appearance using the **Type** button. The choices are:

Passcode Access: The Passcode protected function buttons include a small orange padlock icon within the buttons. This is shown in the left image of Figure 2-60. Touching these buttons will cause a Passcode entry screen to appear, as shown in the left image of Figure 2-58. The correct Passcode must be entered to proceed.

No Access: If the function buttons are protected by No Access, the buttons are grayed out and non-functional, as shown in the right image of Figure 2-60. These buttons cannot be accessed at all unless the restricted protection is removed by switching OFF the **Restricted Access** setting in this menu.

Figure 2-60: Examples of Menu Protection

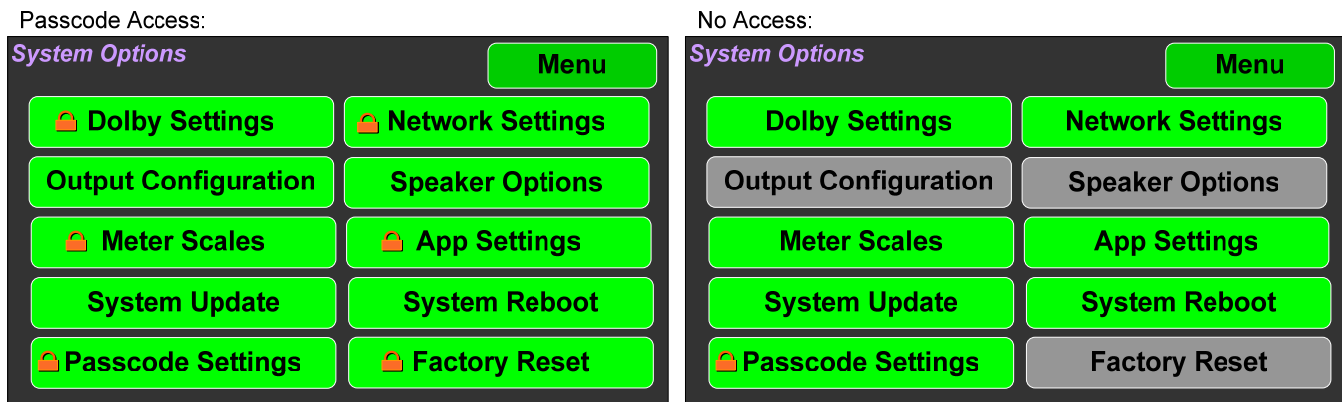

Apply Default: Touching this button returns the settings in this screen to the factory default values. The Passcode becomes 0-0-0-0.

Save: Touching this button saves the settings made in this screen and returns to the **System Options** screen.

Forgotten Passcode

Although the Passcode should be remembered or securely noted somewhere, it can happen that it is forgotten. This can be remedied by performing a Factory Reset from the Wohler Web GUI. Unfortunately, this will also erase all of the menu settings. You may also contact Wohler Technical Service for help.

CHAPTER 3: Technical Info

Table 3-1: iAM-12G-SDI Specifications

Specification	Values/Domains
Power Requirements	100 VAC to 240 V AC \pm 10%, 50/60Hz
Power Consumption	40 Watts
Dimensions (2RU) (H x W x D)	3.5" x 19" x 9.5" (88mm x 483mm x 242mm), standard 19" rack mounting
Weight	11 lbs. (5 kg)
Supplied Accessories	AC Power Cord
Display Type	4.3" (109mm) LCD touchscreen, 24-bit RGB
Number of Displays	2
Screen Resolution	480H x 272V
Level Meters	Simultaneous Average (VU like) & PPM
Level Meter Scale	Digital Scale
Sample Rate	48kHz
De-Multiplexing	16 channels from 12G/3G/HD/SD-SDI
SDI Inputs / Outputs	<ul style="list-style-type: none"> • Two 12G/3G/HD/SD-SDI Inputs and one Output selected from any SDI input • 1 or 2 SDI Inputs or Outputs Optional – Single SFP Transceiver: <ul style="list-style-type: none"> • HD-BNC Coax 3G/HD/SD-SDI • Multi-Mode Fiber: 1 SI Optical SC-Connector, 1300nm • Single-Mode Fiber: 1 SI Optical SC Connector, 1310nm
SMPTE 2022-6 or 2110 Receiver	Optional – SFP Receiver: <ul style="list-style-type: none"> • Multi-Mode Fiber: LC Connectors, 850nm
Cable/Fiber Length (max)	COAX (such as Belden 1694A): > 150 m
	Multi-mode fiber: 1 km
	Single-mode fiber: 10 km

Specification	Values/Domains
AES Inputs	8 AES channel pairs on HD-15
Video Formats	Ultra HD (4K): 2160p23.98/24/25/29.97/30/50/59.94/60 2K: DCI 23.98p/23.98PsF/24p/24PsF 3G: 1080p50/59.94/60 1080p23.98/24/25/29.97/30/ 1080Sf23.98/24/25/29.97/30 1080i50/59.94/60 720p23.98/24/25/29.97/30/50/59.94/60 625i50 PAL 525i59.94 NTSC YcbCr 10 bit 4:2:2
Audio Formats	Dolby ATMOS / E / D / DD+ (E-AC3) Up to 48 kHz audio
SDI Input Termination	75Ω unbalanced
AES/EBU Input Termination	75Ω unbalanced
AES/EBU Sampling Rate	48 kHz
Analog Outputs	16 balanced (8 L/R channels) on 2 x DB25F 2 balanced (1 L/R channel) on 2 x XLR-F +24 dBu max
Analog Output Frequency Response	40 Hz to 20 kHz (\pm 1Db)
Analog Output	<0.01% THD+N
Analog Output Dynamic	> 100 Db
Analog Output Reference	-20 Dbfs = +4 \pm 1.0 dBu
Internal Speakers	Stereo, 80mm, Full Range
Peak Acoustic Output	104 Dba SPL (@ 2 feet)
Hum and Noise	Better than -75 Db below full output
Power Output	15 Watts RMS, 30 Watts peak (each side)
Acoustic Frequency Response	60 Hz to 16 kHz (\pm 5 Db) (-10 Db @ 50 Hz, 20 kHz)
Headphone Output	Stereo, 40 Hz to 20 kHz (\pm 1 Db)
Headphone Load	8Ω to 150Ω

Table 3–2: iAM-12G-SDI Processing Options

Option	Part #	Description
OPT-DOLBY ATMOS	829163	Allows decoding and monitoring of Dolby® D, DD+, E, and ATMOS from SDI, SMPTE 2110, SMPTE 2022-6, and AES streams. Hardware card with software activation key.
OPT-DOLBY	829167	Allows decoding and monitoring of Dolby® D, DD+, & E from SDI, SMPTE 2110, SMPTE 2022-6, and AES streams. Hardware card with software activation key.
OPT-DANTE	829164	Enable monitoring from up to a 64 ch Dante Input. Hardware card with activation key.
OPT-RAVENNA	829165	Enable monitoring from up to a 64 ch Ravenna / AES67 Input. Hardware card with activation key.
OPT-MPEG-H	829185	Enable the ability to monitor and quality check all MPEG-H Audio interactivity options. Software activation key.

Table 3–3: iAM-12G-SDI I/O Options

Option	Part #	Description
SFP-2110 EMBER+	829086	SMTPE 2110 EMBER+ receiver; Multi-Mode 850 NM, LC (fiber) connectors. It can support up to 3G SDI. SFP module with software activation key. Use MN-Set** to configure SFP.
SFP-2110 NMOS	829086-1	SMTPE 2110 NMOS receiver; Multi-Mode 850 NM, LC (fiber) connectors. It can support up to 3G SDI. SFP module with software activation key. Use MN-Set** to configure SFP.
SFP-2022-6	829088	SMTPE 2022-6 receiver; Multi-Mode 850 NM, LC (fiber) connectors. It can support up to 3G SDI. SFP module with software activation key. Use MN-Set** to configure SFP.
SFP-2110 EMBER+ & 2022-6	829087	SMTPE 2110 EMBER+ and 2022-6 receiver; Multi-Mode 850 NM, LC (fiber) connectors. SFP module with software activation key. Use MN-Set** to configure SFP.

SFP-2110 NMOS & 2022-6	829087-1	SMTPE 2110 NMOS and 2022-6 receiver; Multi-Mode 850 NM, LC (fiber) connectors. SFP module with software activation key. Use MN-Set** to configure SFP.
OPT-DANTE OPT-RAVENNA	829171 829172	AoIP option card to enable decoding and monitoring of up to 64 ch of Dante™ OR Ravenna™ / AES67/ 2110-30 Input streams with NMOS Support. Provides 2 x RJ-45 ports for 2022-7 support + SFP cage allowing MM and SM SFPs as an alternate primary for AoIP Signals. TOSLINK included.
SFP-SDI	829089	3G/HD/SD-SDI single video receiver with active loopback, HD-BNC connectors. SFP module with software activation key.
SFP-12G-SDI- FIBER	829160	12G/3G/HD/SD-SDI single mode Opt. LC (fiber) video receiver. LC (fiber) connectors.
SFP-SDI-FIBER	829084	3G/HD/SD-SDI video SFP optical input; LC (fiber) connectors; Single-Mode Receiver, Medium Haul, Non-MSA, no output; (video only) with software activation key.
SFP-SDI- Output	829083	3G-SDI Transmitter module; HD-BNC connectors; Audio and Video Output (video output at 1080p60) are from the monitored source. SFP module with software activation key, for use in the SFP Output Module Cage only.
SFP-HDMI- Output	829155	HDMI/DVI Output module; Video output at 1080p60 from the monitored source. 2 Channel Audio support as well. SFP module with software activation key, for use in the SFP Output Module Cage only.
OPT- MADI/ANLG/ TOS (12G)	829168	Multiple Interface module; 8 Analog channels on DB-25 receiver, Optical TOSLINK receiver, 1 x MADI64 input via BNC, SFP cage for MADI Optical input, Primary and Secondary 1 GB Ethernet connectors for Dante64 or Ravenna64 / AES67 processing options.
SFP-MADI-MM- Fiber	829081	MADI optical fiber receiver; Multi-Mode, LC (fiber) Connectors. SFP Module with software activation key.
SFP-MADI-SM- Fiber	829082	MADI optical fiber receiver; Single-Mode, LC (fiber) Connectors. SFP Module with software activation key.

****MN-Set** is configuration software that is necessary so that you can set up this module. It is available at no cost either from its manufacturer, Embrionix, or by contacting Wohler Technologies Technical Service.

Figure 3-1: iAM-12G-SDI Block Diagram

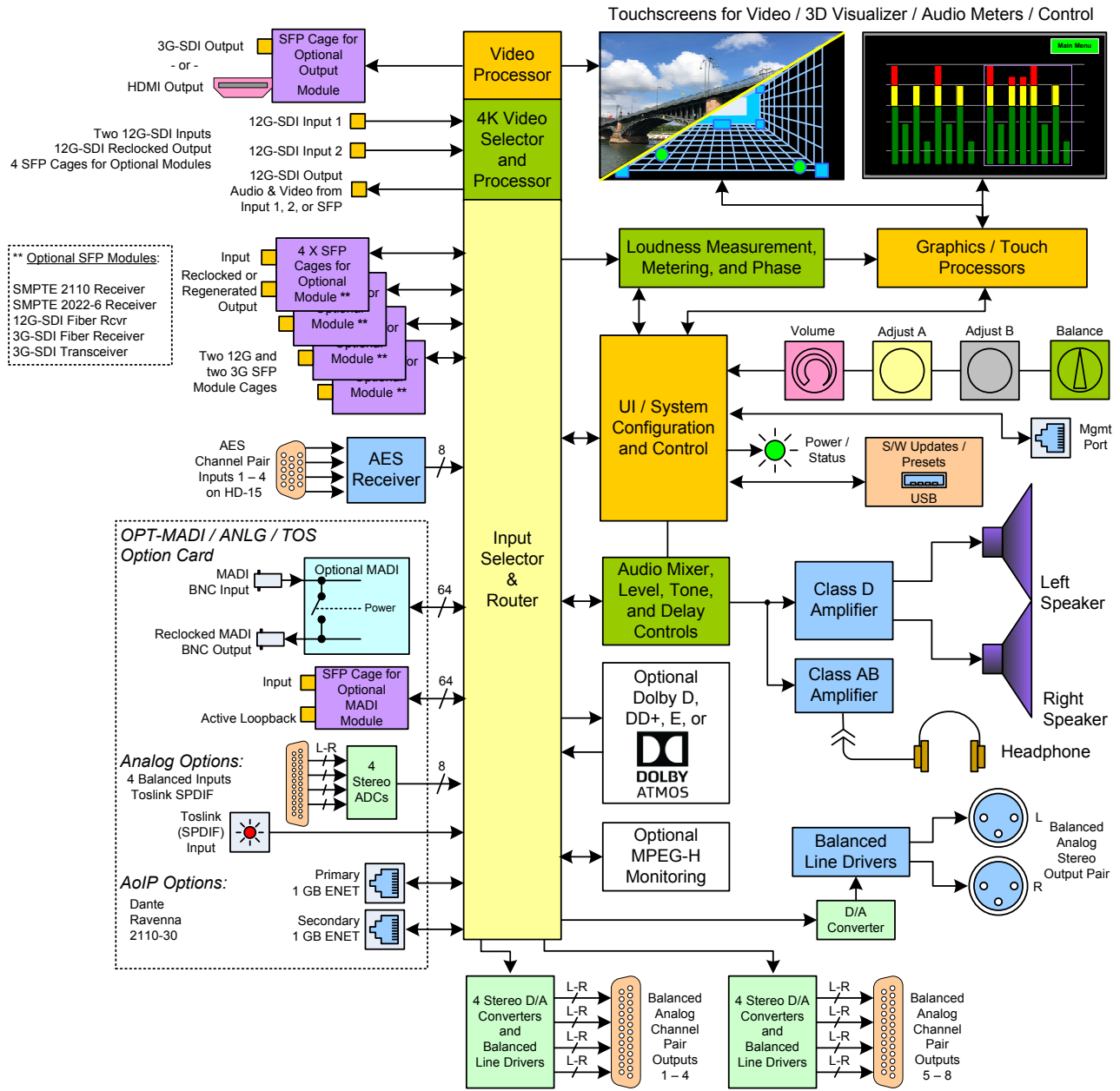

CHAPTER 4: The iAM-12G-SDI Web GUI

The self-contained iAM-12G-SDI Web GUI allows you to customize the configuration of the iAM-12G-SDI to suit your needs. If the default configuration of the iAM-12G-SDI suits your needs and you prefer to use it that way, then you do not need to use the iAM-12G-SDI Web GUI.

Web Browser / Control Device

Any web browser application running on any networked device such as desktop or laptop computer, tablet or smart phone can be used with the iAM-12G-SDI Web GUI.

Tablets with no network connector need to be linked to a copper LAN through a Wi-Fi adapter.

Although they can be used, smart phones are not recommended because their smaller screen size would require more scrolling, making operation challenging.

The Chrome[®] web browser is recommended for speed and compatibility.

First Time IP Assignments

The iAM-12G-SDI can operate with a static (fixed) or dynamic (DHCP) IPv4 address. When received from the factory the default address will be **169.254.1.xx** where xx is the last octet of the management Mac address. For example, if the Mac address is b4:ed:54:d0:04:28 then the IP address would be 169.254.1.40 (40 is the decimal equivalent for the last octet of Mac address 28.) There two basic types of connections that may be used to connect the iAM-12G-SDI to a web browser, a **Peer-to-Peer Connection** or a **Network Connection**.

Peer-to-Peer Connection

The most straightforward way to connect the iAM-12G-SDI to a web browser, free of possible network conflicts, is to establish a static peer-to-peer connection between the setup computer and the iAM-12G-SDI. A 10/100/1000 MHz Ethernet switch may be used in between, but is not required.

Figure 4-1 shows an example of suitable address settings for the host computer in a Windows 7 control panel.

Figure 4–1: Host IP Settings

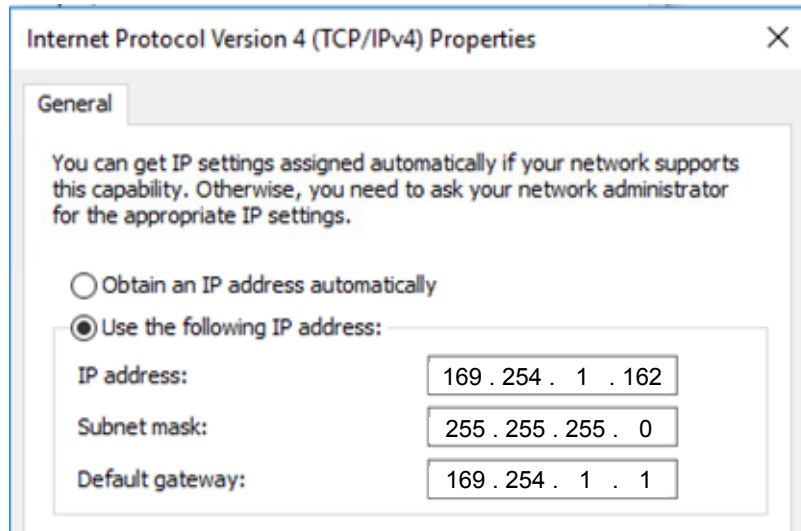

Close the control panel and reboot the host computer after making an IP address change to be sure the change takes effect. **Either reconnect to the installed network or continue with this direct connection to access the iAM-12G-SDI Web GUI.**

Network Connection

When connected to a network, the iAM-12G-SDI address will need to be changed to another address in order to be compatible with the address assignments for that particular network. Immediately after the host setup is complete, change the iAM-12G-SDI's address. Make the corresponding address, mask and gateway changes in the iAM-12G-SDI **Network Setup** page. Refer to the **Network Setup** section of this chapter and Figure 4-11.

Otherwise set the iAM-12G-SDI to DHCP address mode by checking the box for 'Use DHCP?' in Network Setup and have your IT administrator assign rights and settings for operation on the network. Allow enough time for your network's DHCP server to recognize a new network device and assign an address after booting.

The iAM-12G-SDI uses link local addressing for its internal network, so no accommodation for this need be made in the network.

Dashboard

Throughout the Web GUI, pages are a click or two away using the list of selections on the left side. The **Dashboard** page shows all of the available Preset configurations at a glance. The iAM-12G-SDI allows you to assign Presets to particular groups. In Figure 4-2, although 24 Presets have been defined, only the single Favorite Preset is shown.

Figure 4-2: Dashboard Preset Overview

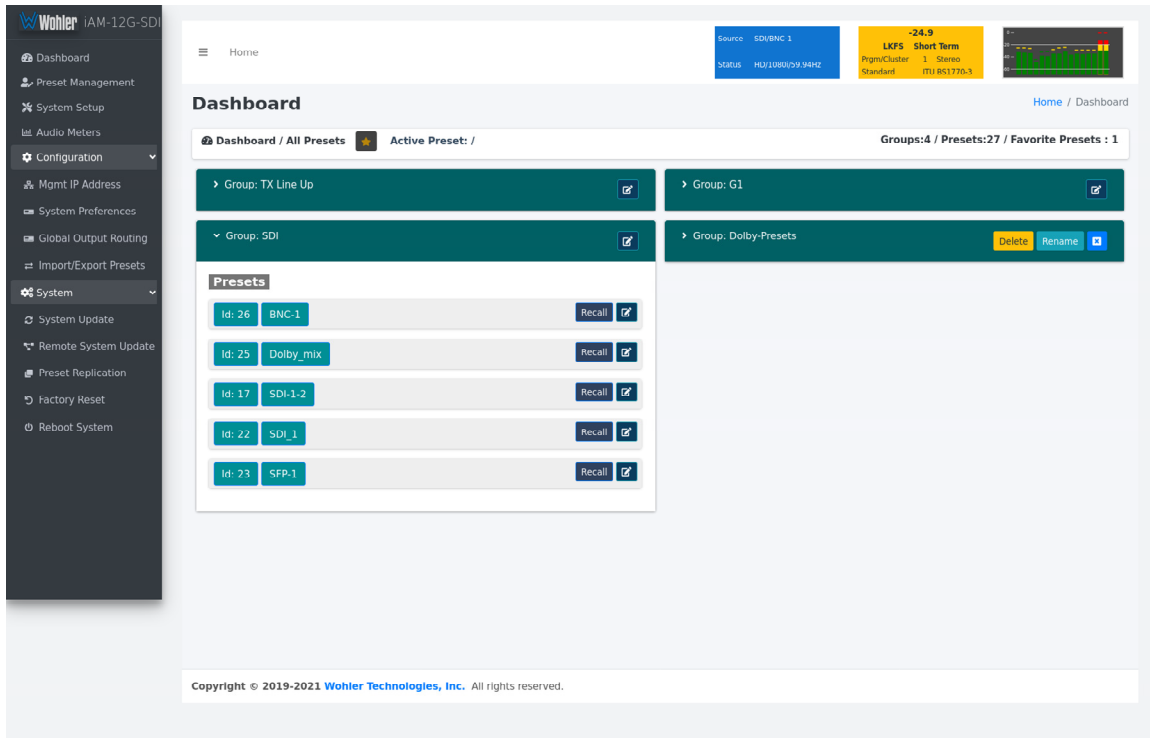

To view all of the Presets within a group, click on that group.

In Figure 4-3, it can be seen that there are three Presets in the Operator-1 group and only one Preset in the Operator-2 group. The currently selected active Preset for local operation is shown in red. In Figure 4-3, this is the Preset named SDI-AES-Mix.

Figure 4–3: Dashboard Preset Recall / Edit

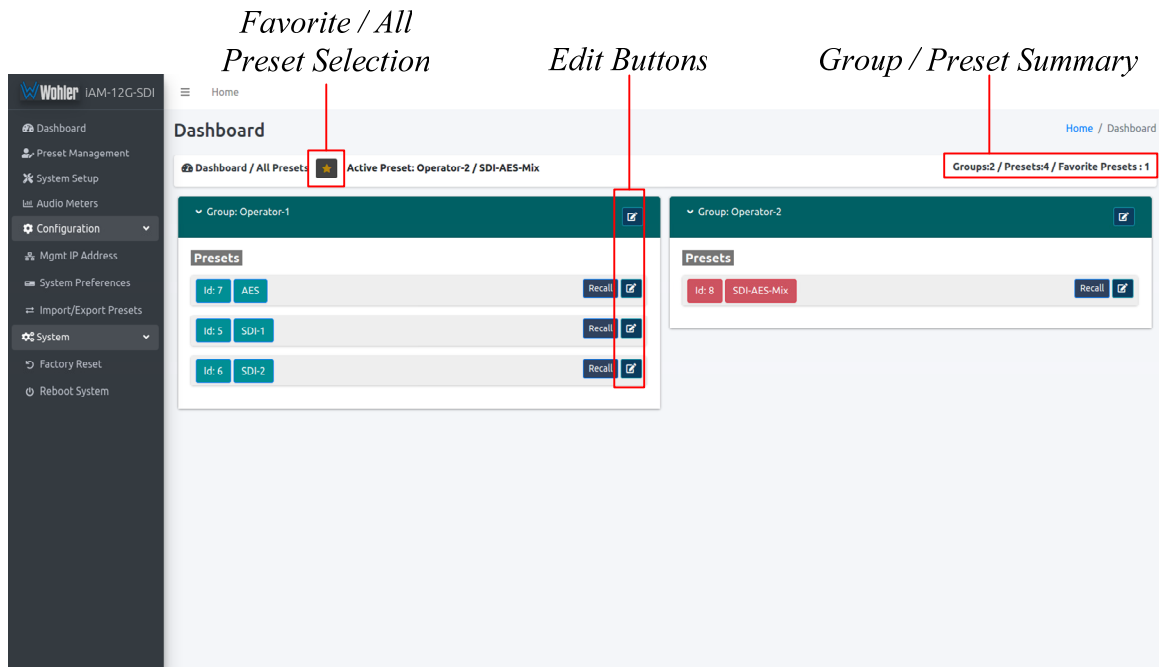

A Group / Preset Summary is shown in the upper right of the screen. This enables you to see the total number of Groups, Presets and Favorite Presets in the iAM-12G-SDI.

Use the  button, as shown in Figure 4-3, to toggle between Favorite Presets or All Presets.

Click the **Recall** button to recall a Preset. To Edit a Preset, click the **Edit** icon, as shown in Figure 4-3, to the right of the associated **Recall** button.

After clicking the **Preset Edit** button, the screen shown in Figure 4-4 will appear. Clicking a **Group Edit** button will cause the screen in Figure 4-5 to appear.

Figure 4–4: Dashboard Preset Edit

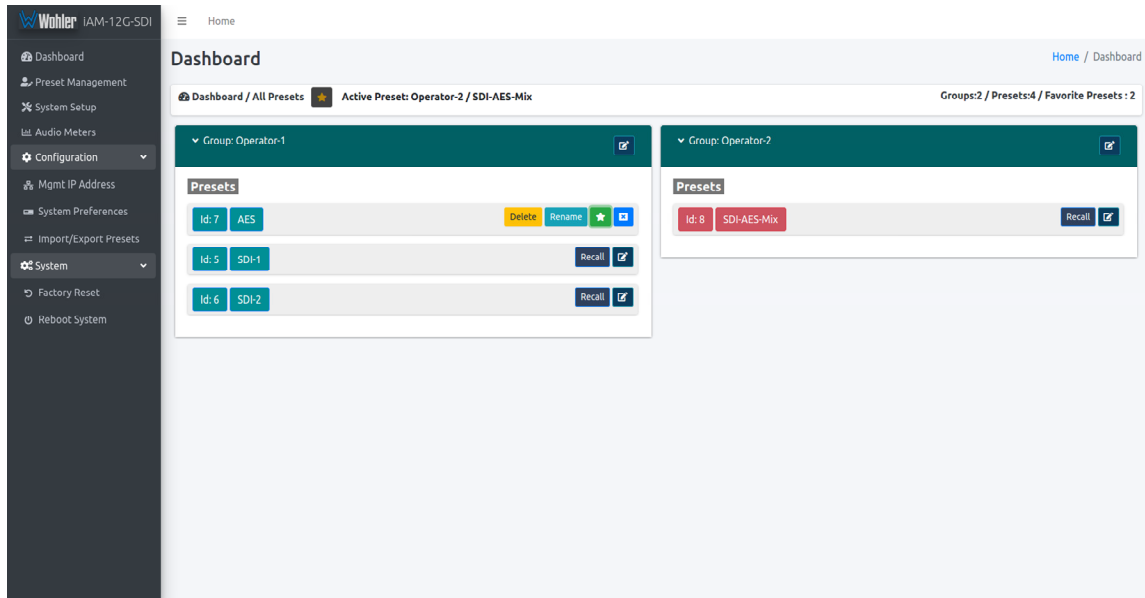

The Edit options for a Preset are:

1. Delete: Remove the Preset from the system. **Do Not delete the currently active Preset.**
2. Rename: Rename the Preset, but keep all of its other characteristics.
3. Make Favorite: Make this Preset a favorite. This can be done for frequently used Presets.

Figure 4–5: Dashboard Group Edit

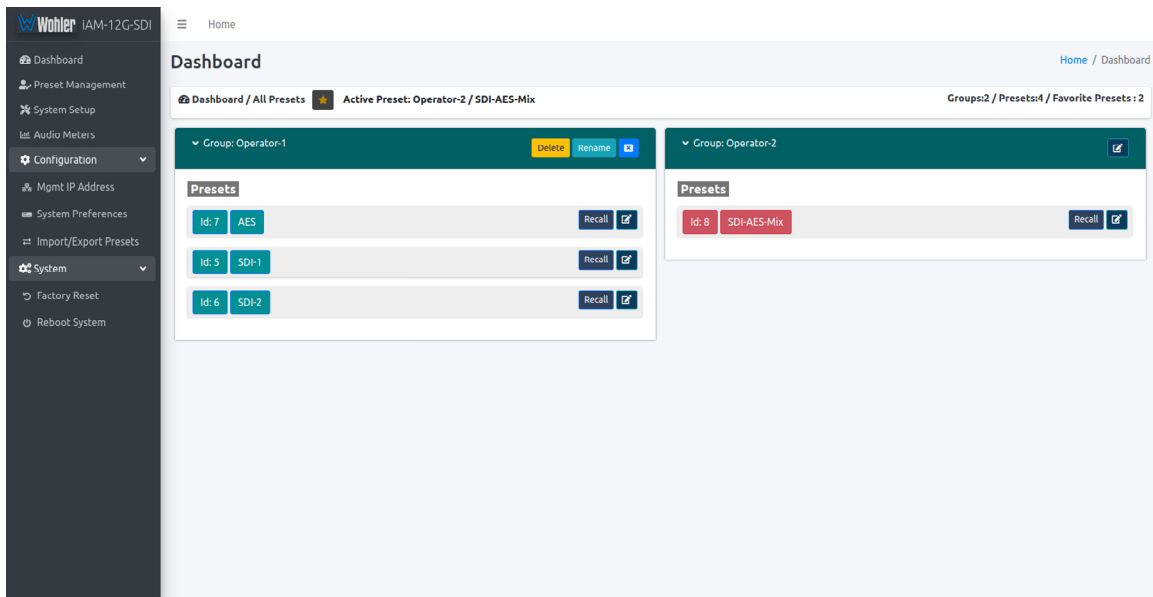

The Edit options for a Group are as follows:

1. Delete: Delete the Group and all of the Presets it contains.
2. Rename: Rename the Group, but keep all of its other characteristics.

Preset Management

Although the **Source Select** function, as described in the Source Select section of Chapter 2, can be used to choose which input sources to monitor, often a more customized input monitoring scheme will better meet your needs. Inputs from multiple sources can be arranged in logical metering and monitoring configurations using Presets. Almost any number of Presets can be created, saved, and identified with unique names of your choosing. Using these names, Presets can be recalled immediately from the iAM-12G-SDI front panel.

Preset Input Routing

The **Configuration - Preset Management - Preset Input Routing** tab is where the routing of input source signals to the meters and the speakers can be defined in virtually any arrangement.

Presets are monitoring configurations that can be composed of channels from multiple sources and displayed on the meters in any order. Presets should be set up to allow operators to quickly shift between setups for monitoring. The **Configuration - Preset Management** screen contains selections of all of the details for a Preset, and is largely arranged in a matrix format connecting input channels to monitoring channels. The screen is shown in Figure 4-6.

Figure 4-6: Configure Presets

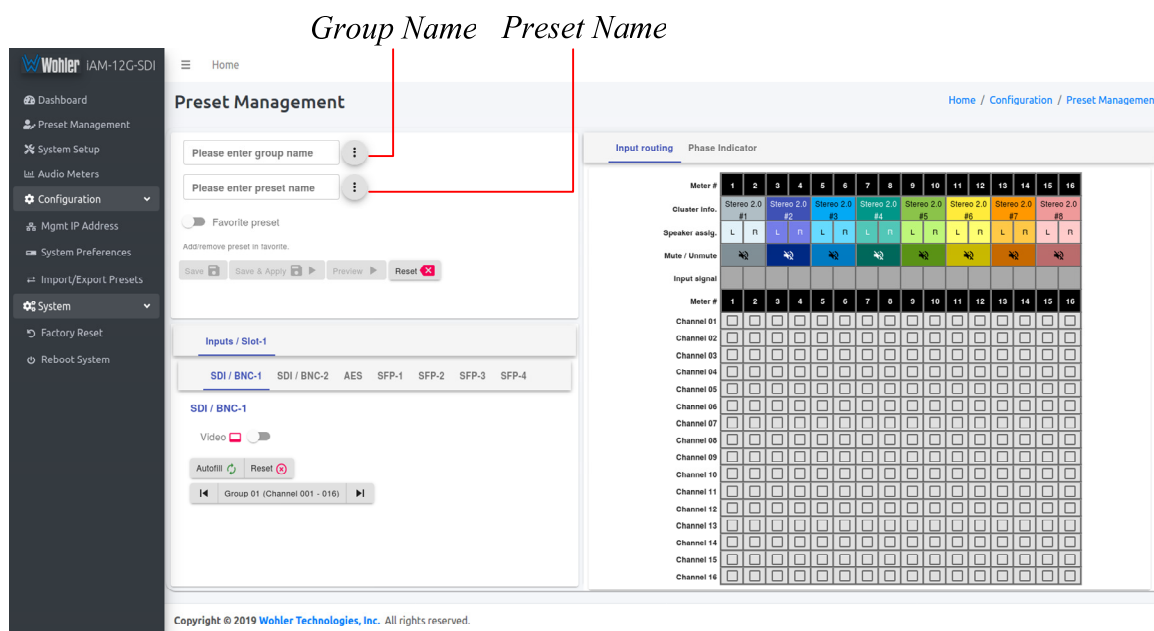

1. **Preset Configuration:** You may create a new Preset, adjust an existing

Preset, or create a new Preset from an existing Preset. Refer to Figure 4-7:

- **To create a new Preset**, first either select a Group from the pull down list or type the name of a new Group in the Group Name field provided. Then enter a name for the new Preset in the Preset Name field. Then make all of the settings needed and save it.
- **To make changes to an existing Preset**, select the Group and Preset from the pull down lists, make the needed changes and save it.
- **To create a new Preset starting with an existing Preset**, first select the Group and the existing Preset from the pull down lists. Next, enter the name for the new Preset and save it. Then make the needed changes and save it again.

Figure 4-7: Create / Adjust Preset

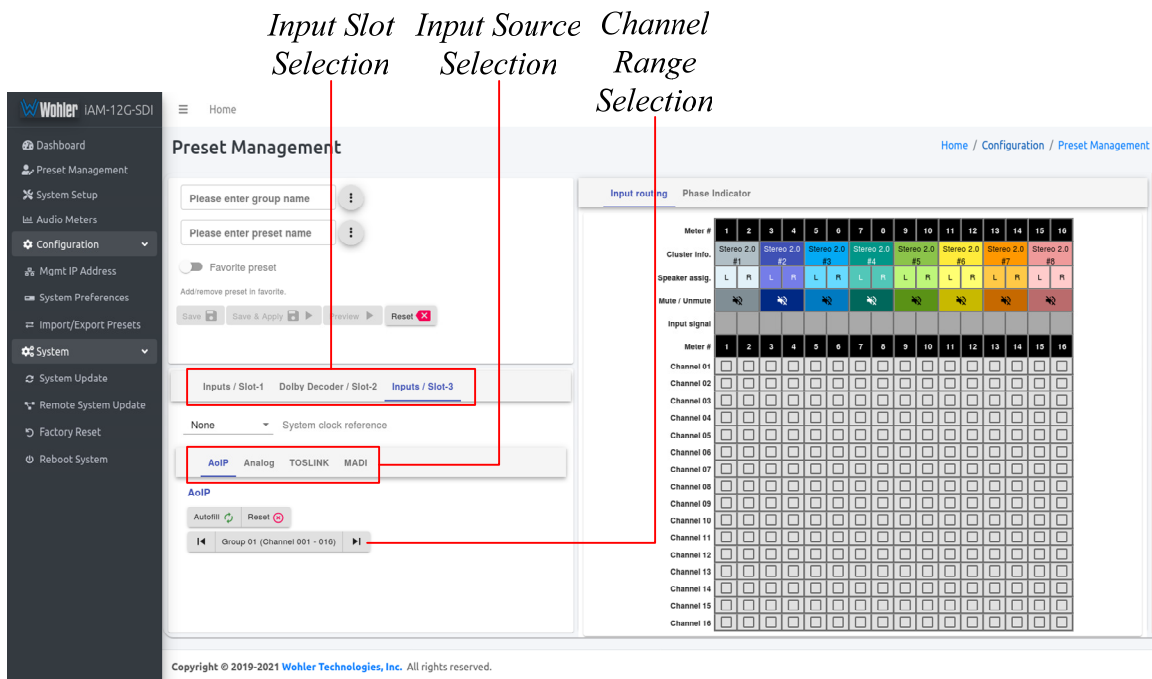

2. **Input Selection:** Audio from any of the input sources in a given Input Slot (option module) may be applied to the monitoring scheme in any way. For example, you may have 6 channels from an SDI stream, along with 2 AES channels, and along with 2 analog channels assigned your choice of meters. A **Preset Input/Output Matrix** is provided on the lower right side of the screen to allow you to assign each channel. Simply select each input source, one at a time, and then check the boxes in the **Matrix** to apply each input channel number to a metered channel number. They do not have to be applied in any specific order. The order of assignment should be chosen to make it easy for the operator to understand. If there are more than 16 channels in a source, the desired Channel Range of 16 can also be selected from the box in the lower left of the screen.
3. **Autofill Selection:** If you simply want to map all 16 input channels to all 16 meters in the same order, click the **Autofill** button. The **Preset Input/Output Matrix** will automatically fill out. To remove all mapping,

click the **Reset** button that is adjacent to the **Autofill** button.

4. **System Clock Reference:** For reliable operation, it is imperative that an appropriate clock reference selection be made. This is done in a pull down menu. Refer to Figure 4-8. **The lack of an appropriate clock reference may result in erratic monitoring or no ability to monitor at all.**

Figure 4-8: System Clock Reference

System Clock Reference

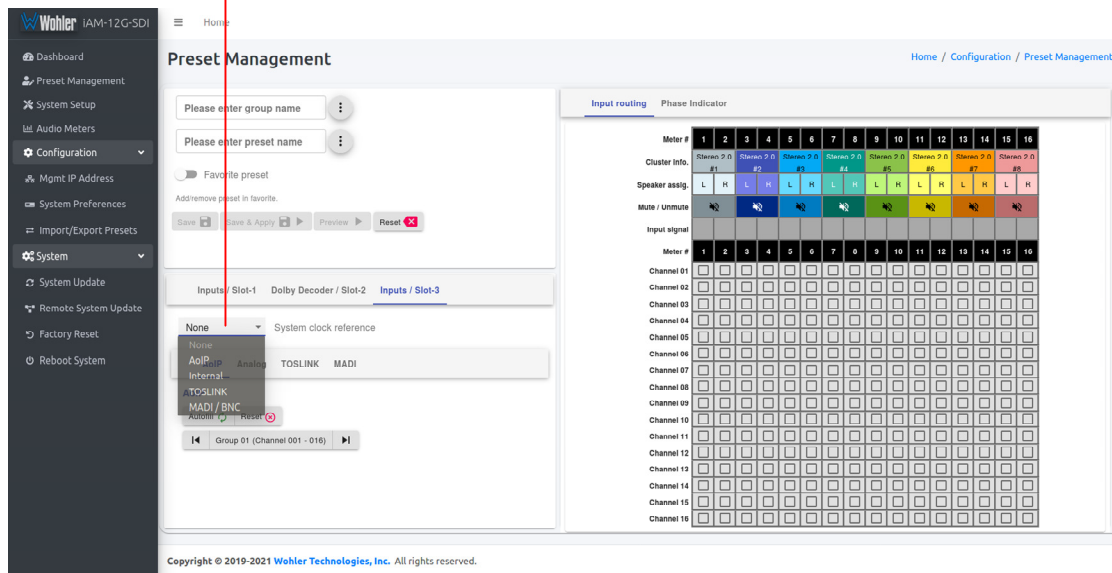

5. **Cluster Definition and Naming:** Channel Clusters are a series of channels that are all associated with monitoring the same signal. For example, a Stereo Cluster consists of two channels that together monitor a stereo signal. A Surround 5.1 Cluster consists of 6 channels that together monitor a 5.1 surround sound signal. Refer to Figure 4-9. Clicking a **Cluster Info** box opens a **Cluster** selection box.

Figure 4–9: Cluster Assignment

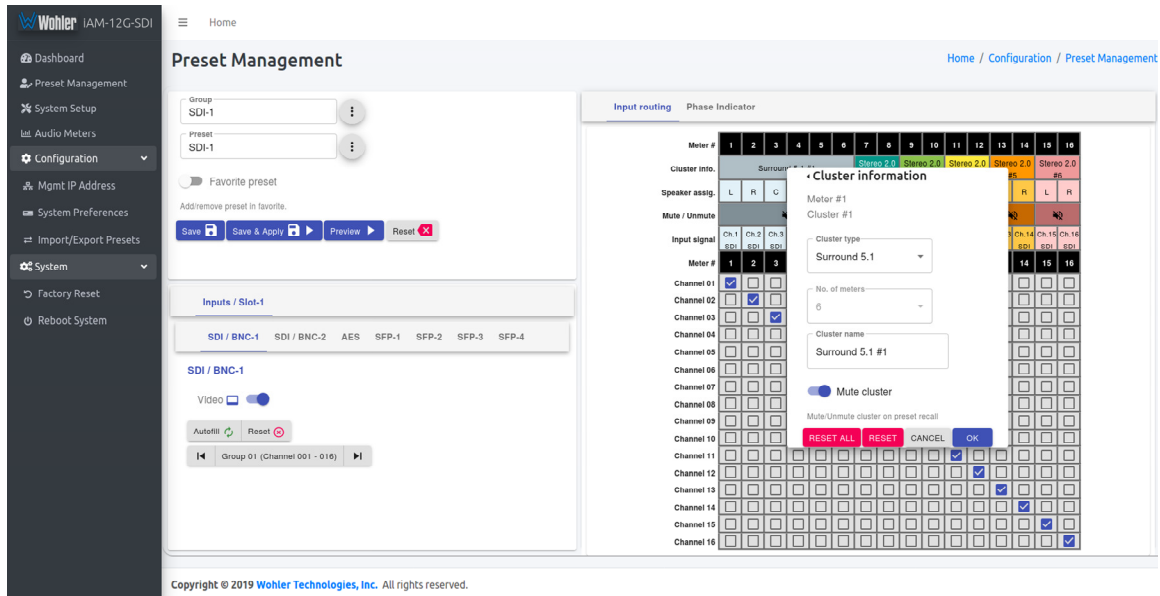

In the **Cluster** box, you can select the type of Cluster from a pull down selection. The available **Cluster Type** selections are:

- Mono 1.0: The channel will appear within a single-channel cluster.
- Stereo 2.0: The channels will appear within a two-channel cluster.
- Surround 5.1: The channels will appear within a 6-channel cluster.
- Surround 7.1: The channels will appear within an 8-channel cluster.
- Custom: You may define a 0 to 8 channel cluster.

Multichannel clusters will expand to the right and overwrite any clusters on overlapping meter positions.

By default, all odd numbered channels will map to the left speakers and all even numbered channels will map to the right speakers. You may change this using the crosspoint selections in the Input/Output Matrix.

A default name will be chosen and it will appear on the metering screen. You may name the Cluster anything you want by simply changing the words within the **Cluster Name** field.

When finished, click **Update**. To undo your change, click **Reset**. To undo all of the Cluster changes for the 16 channels, click **Reset All**. Click **X** to close the box.

6. **Speaker Assign:** Speaker assignments are made automatically when a cluster is set. However, it can be that in an actual signal, the channel assignments may be different than what the automatic assignment assumes. A speaker assignment adjustment is provided for each channel, should you need to override the automatic settings. **It is important to accurately assign the function of each channel so that the Loudness calculations will be accurate.** Clicking a **Speaker Assign** button on a channel opens a box that lets you change the current setting. Click **OK** or **Cancel** to close the box. Refer to Figure 4-10.

Figure 4–10: Speaker Assignment

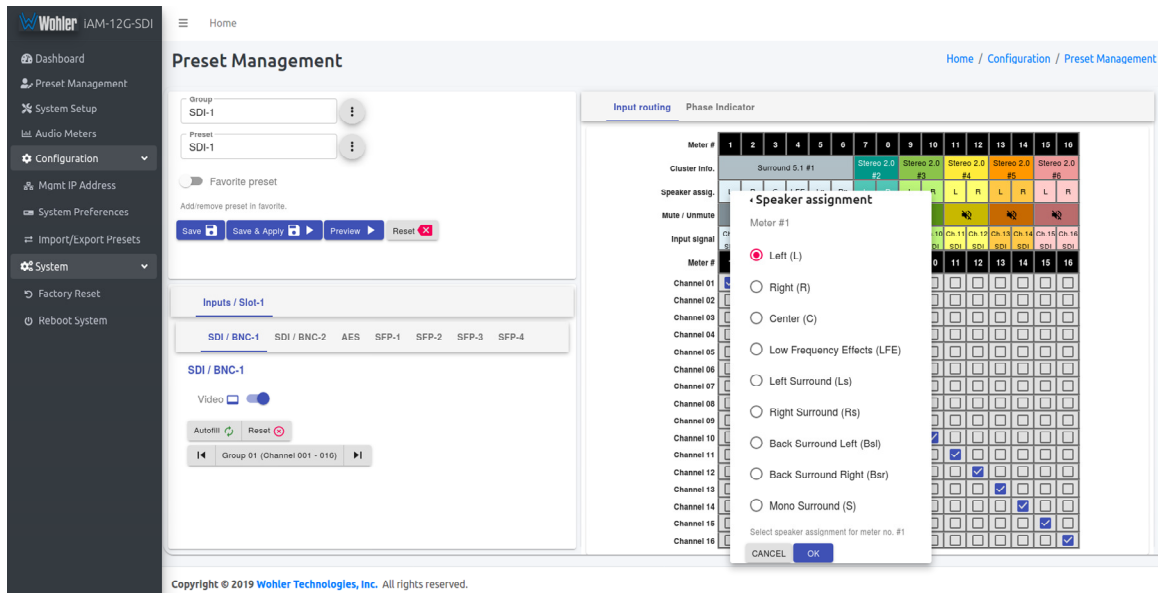

7. **Mute/Unmute:** A **Mute/Unmute** control is provided for each channel, although the adjustment will affect all channels in the Cluster. This allows the operator to just see the meters for certain channels and not hear the audio. This is an alternate action control.

8. **Channel Information:** Hovering over each red/yellow/green **Channel or Cluster Info** box opens a summary of channel settings. You may use this to verify that you have correctly entered the needed channel settings.

Presets may be created for any licensed inputs, even if the SFP module for an input is not plugged into its respective socket at the time. This makes it easy to swap SFP input modules without having to recreate presets after the insertion or removal of an SFP module. Note that if a licensed SFP module is not detected, such as when one is removed to be swapped, its monitoring inputs will be muted. Likewise, if the required license has not been entered for an SFP module that is inserted, its monitoring inputs will also be muted. Refer to the **Licenses** section in this chapter and to Figure 4-18 to install software licenses.

9. When you have finished creating a Preset or making changes to a Preset, either click the **Save** button to save the Preset, click the **Save & Apply** button to save the Preset and make it the current Preset, or click the **Reset** button to discard the changes just made. These selections can be seen in Figure 4-9.

Dolby Presets

Dolby Presets are useful for customers who want to simultaneously monitor both Dolby decoded channels and other inputs or want to have an auto-zoom to monitor a certain pair that is known to be carrying Dolby encoded audio.

Creating a Dolby Preset is in many ways very similar to creating any other Preset. Refer to the **Preset Input Routing** section of this chapter. Figure 4-11 shows a Dolby Preset being created.

Figure 4-11: Creating a Dolby Preset

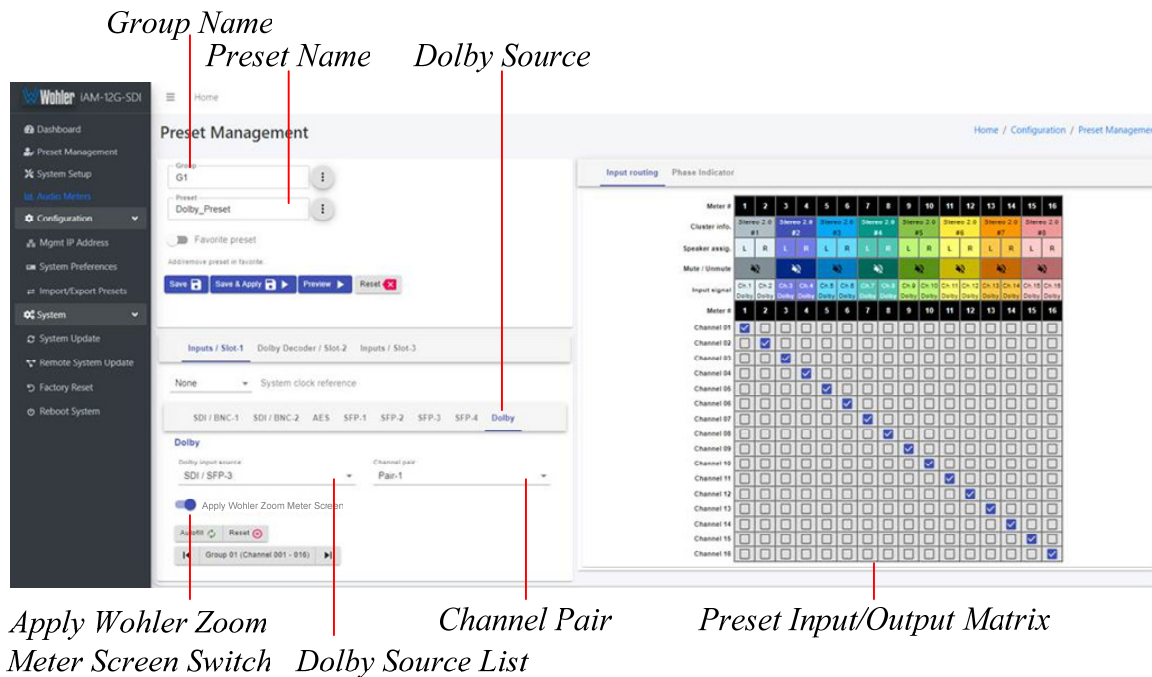

After clicking **Preset Management** in the list on the left, and selecting or creating a Group name and Preset name, as shown in Figure 4-11, use the following steps to set up a Dolby Preset:

1. Click the **Dolby Input Source**, as indicated in Figure 4-11. A list of all of your physical inputs will display. Select the one containing the Dolby signal that you are interested in monitoring.
2. Click the **Channel Pair**. A list of all of the channel pairs in your selected source appears. Select the one that contains the Dolby signal to be monitored.
3. Using the **Preset Input/Output Matrix**, select which decoded Dolby channels should appear on which meters. To automatically fill out this matrix, mapping channels 1 - 16 to meters 1 - 16, simply click the **Autofill** button. Note that by default, channels 15 and 16 are a downmix of the decoded Dolby channels.
4. Moving the **Apply Wohler Zoom Meter Screen Switch** to the **ON** position (to the right) allows you to view the Dolby Preset in a similar way as the **Wohler Zoom Screen** is seen. When this is done, the **Wohler Zoom Screen** will have the **Exit Dolby** button replaced by a **Menu** button, as shown here:

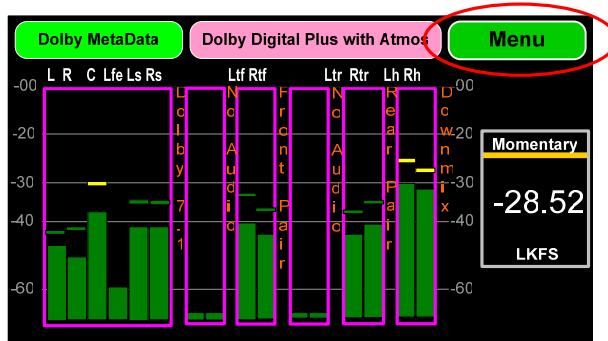

Note: If the **Apply Wohler Zoom Meter Screen** option is turned on and if **Apply Common Dolby Configurations** is selected while creating a Dolby preset, the channel clustering shown on the screen follows the **Speaker Configuration** as set in the **Dolby Configuration**. Otherwise, the channel clustering shown on the screen follows the speaker configuration selected while creating a Dolby preset.

Note: The **Loudness** calculations are always done on the Dolby channels, even if the Preset has other mixed channels.

Refer to Figure 4-12 to configure the Dolby decoder for this Preset.

Figure 4-12: Dolby Decoder Configuration

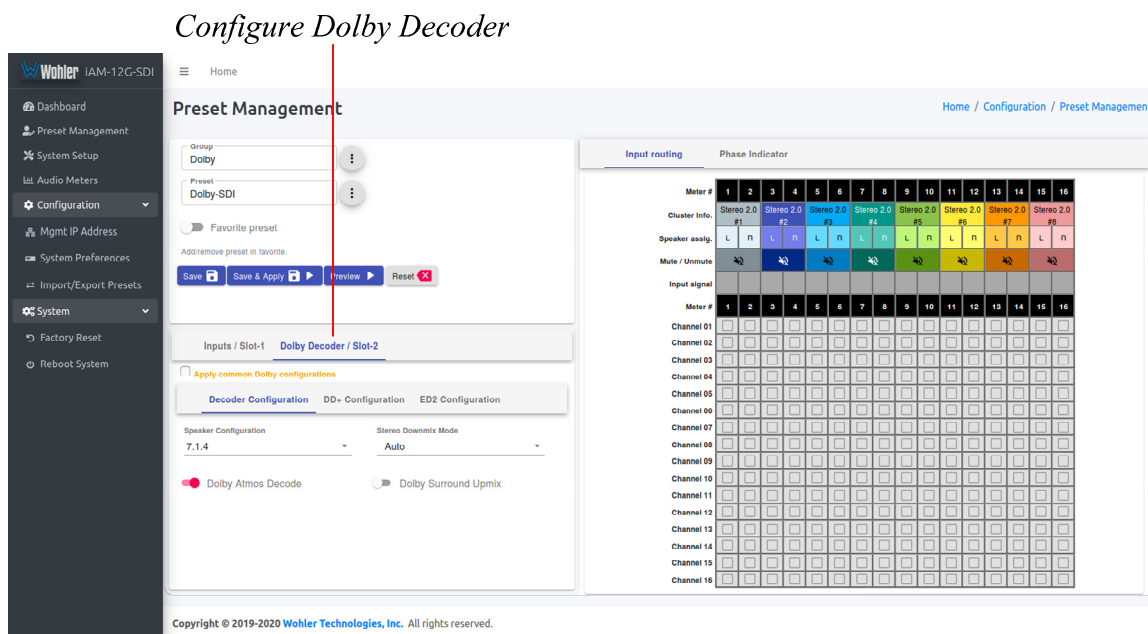

Click the **Dolby Decoder** tab, as indicated in Figure 4-12. You may then select from the tabs below it to choose the following:

1. Decoder Configuration
2. DD+ Configuration
3. ED2 Configuration

Each of these tabs contains one or more settings that you can set up to customize the decoder behavior. Select each one to set them according to your preferences, to be used in this Dolby Preset only.

Alternatively, if you would rather set up the Dolby Decoder to operate as is set in

the Common Dolby configuration of this unit, simply click the **Apply Common Dolby Configurations** checkbox. The **Dolby Settings** section of this chapter explains the **Common Dolby Configurations**. The screen will then appear as is shown in Figure 4-13.

Note: You may also replace some of the decoded channels with un-encoded input source channels so that they can all be monitored on the same meter screen. To do this, use the following steps:

1. In the **Preset Input/Output Matrix**, uncheck the Dolby channels that will be replaced from the numbered meter positions.
2. Click the **Inputs** tab shown in Figure 4-13.
3. In the row of tabs below the **Inputs** tab, click the tab for the source for the channels you want to replace some of the decoded Dolby channels. After you do this, the unchecked columns in the **Preset Input/Output Matrix** are highlighted and can now be checked for the source channels that you want to monitor, routing them to the meters you choose.

Note: If you combine decoded Dolby channels with other channels on the same metering screen, if they do not have the same clock source, audio glitches can appear.

Figure 4-13: Apply Common Dolby Configurations

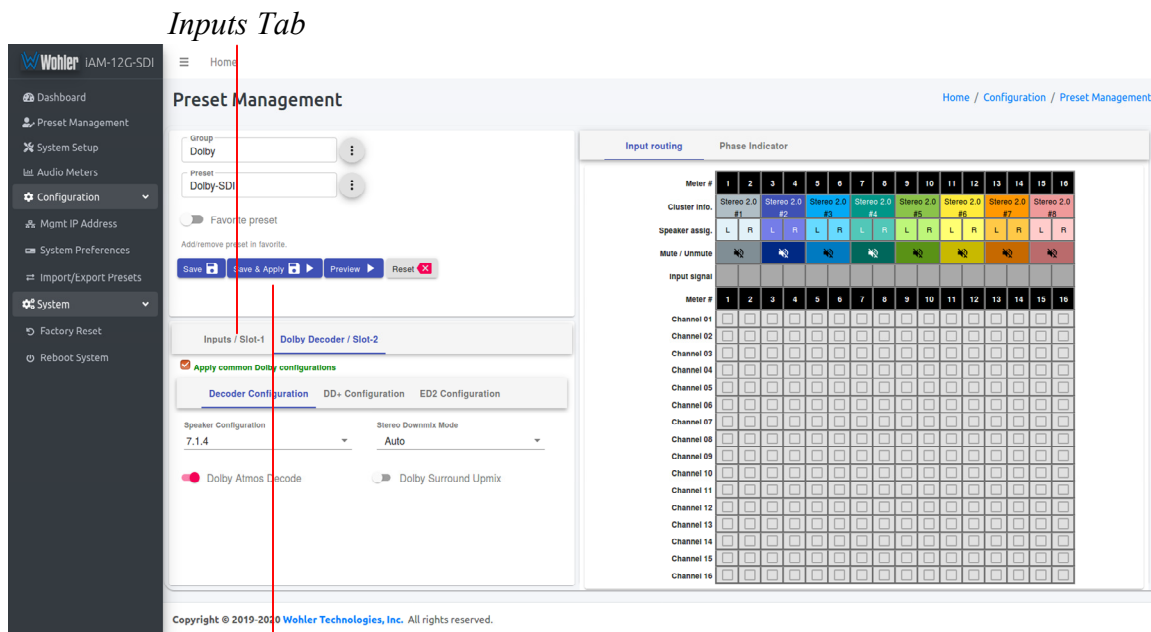

Save & Apply

When you have finished making all of the settings for this Dolby Preset, click **Save & Apply**.

MPEG-H Presets

MPEG-H monitoring is an optional feature, which may be purchased at the time of product purchase or later. MPEG-H Presets are useful for customers who want to simultaneously monitor both MPEG-H channels and other inputs.

Important Note: For MPEG-H monitoring, the preset created to monitor MPEG-H signal should not contain any Dolby channels. If an input SDI signal has both Dolby & MPEG-H channels, then for MPEG-H monitoring, a preset should be created that skips any Dolby channels. You may monitor either Dolby signals or MPEG-H signals, but not both at the same a time by setting separate Dolby and MPEG-H presets.

Creating an MPEG-H Preset is in many ways very similar to creating any other Preset. Refer to the **Preset Input Routing** section of this chapter. Figure 4-14 shows an MPEG-H Preset being created. To monitor the MPEG-H signal, you must create a preset with the settings shown in Figure 4-14. In the MPEG-H signal, MPEG-H control track is always present in the 16th meter slot (16th channel) and that must be selected.

Figure 4-14: Creating an MPEG-H Preset

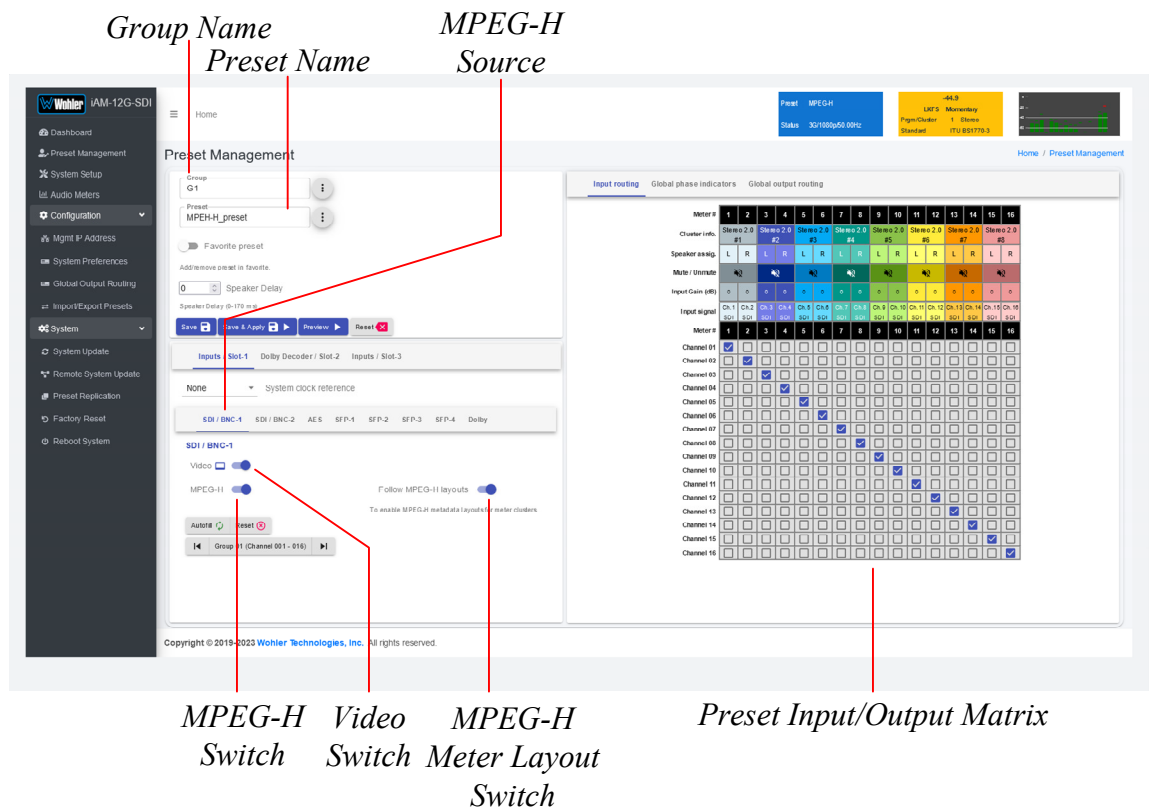

After clicking **Preset Management** in the list on the left, and selecting or creating a Group name and Preset name, as shown in Figure 4-14, use the following steps to set up a Dolby Preset:

1. Click the **SDI Input Source containing the MPEG-H channels**, as indicated in Figure 4-14.
2. Turn **ON** the **MPEG-H Switch** and the **Video Switch**.
3. Turn **ON** the **Follow MPEG-H Inputs Switch** or use the **Preset Input/Output Matrix** to select which MPEG-H channels should appear on

which meters. To automatically fill out this matrix, mapping channels 1 - 16 to meters 1 - 16, simply click the **Autofill** button. Note that by default, channel 16 is the MPEG-H control channel and it must be selected.

When you have finished making all of the settings for the MPEG-H Preset, click **Save & Apply**. After applying the MPEG-H preset, monitoring of the MPEG-H signal starts and its metadata can be seen on the MPEG-H Metadata tab on the Audio Meters menu as shown in Figure 4-15.

Figure 4-15: Audio Meters MPEG-H Metadata Tab

The screenshot shows the Wöhler iAM-12G-SDI Audio Meters interface. The main content area is divided into several sections:

- Presets:** A table showing preset configurations.

Label	Kind	Loudness
Default	Undefined	-31.75
Members		
Name	Gain	Gain Interac.
5.1+4H Bed	0	Yes
Language	0	Yes
Dialog		
	Hearing Impaired (LI)	-22.75
Commentary off		
	Undefined	-39.75
- Switch Groups:** A table showing switch group configurations.

Label	Members
Language	<ul style="list-style-type: none"> English German French Italian Russian
- Components:** A table showing component details.

Label	Type	Layout	Kind	Language	Gain Int (dB)	Asm. Int (deg)	Elev. Int (deg)	Loudness	Audio Tracks			
5.1+4H Bed	Channel	5.1+4H	Bed (Mixed)	Unknown	0	0	0	-40.00	1 2 3 4 5 6 7 8 9 10			
English	Dynamic Object	Unknown Layout	Commentary	English	-6	12	-90	80	0	39	-31.75	11
German	Dynamic Object	Unknown Layout	Commentary	German	-6	12	-90	80	0	39	-33.50	12
French	Dynamic Object	Unknown Layout	Commentary	French	-6	12	-90	80	0	39	-33.75	13
Italian	Dynamic Object	Unknown Layout	Commentary	Italian	-6	12	-90	80	0	39	-32.75	14
Russian	Dynamic Object	Unknown Layout	Commentary	Russian	-6	12	-90	80	0	39	-31.00	15
- Components Top View:** Two diagrams showing channel and dynamic object layouts. The left diagram is labeled "Channels Layout : 5.1+4H Bed" and the right is "Dynamic Objects : 5". A table on the right shows dynamic object details.

Dynamic Objects	index	Azimuth	Elevation
English	2/1	0.0	0.0
German	3/1	0.0	0.0
French	4/1	0.0	0.0
Italian	5/1	0.0	0.0
Russian	6/1	0.0	0.0

Phase Indicators by Preset

The **Configuration - Preset Management - Phase Indicator** tab is where the Phase Indicators can be enabled to show on the Audio Meters screen or whether they shouldn't according to each Preset. Generally speaking, the Phase Indicators should be shown, but if the channels of any pair contain dissimilar material, then the Phase Indicator for that channel pair should be disabled. This is to keep the operator from seeing the Phase Indicator frequently but needlessly light. An example of this situation would be when the Center channel and the LFE channel are on the same pair in a 5.1 configuration.

Figure 4-16: Preset Management - Phase Indicator

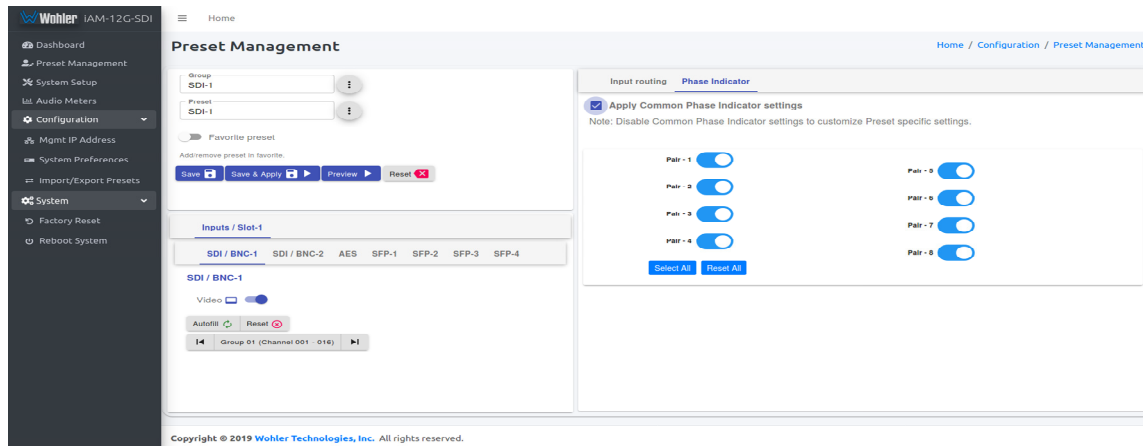

Follow these steps to create a unique Phase Indicator setup for a Preset:

1. If the Phase Indicator setting in this Preset is to be different from the Common Phase Indicator setting, then uncheck the Apply Common Phase Indicator Settings box.
2. Click on any channel pair switch(es) to enable or disable the Phase Indicator for that channel pair.
3. When you have finished creating a Preset or making changes to a Preset, either click the **Save** button to save the Preset, click the **Save & Apply** button to save the Preset and make it the current Preset, or click the **Reset** button to discard the changes just made. These selections can be seen in Figure 4-16.

Output Routing by Preset

The **Output Routing** tab allows you to determine exactly which input channels are routed to which outputs. It appears as shown in Figure 4-17. This very flexible capability allows you to route signals according to Preset or as a default for the whole system. Refer to the **Global Output Routing** section in this chapter to learn the function of each of the checkboxes and of the matrix in this tab.

To set up a different input to output routing scheme for the Preset you are creating, click the **Global Output Routing** tab and uncheck the **Apply Global Output Routing** checkbox. You may then adjust the output routing as you desire on this tab and it will only apply to this Preset.

Figure 4-17: Global Output Routing Preset Tab

Global Output Routing Tab

The screenshot displays the 'Global Output Routing' tab within a 'Preset Management' interface. On the left, there are input fields for 'Please enter group name' and 'Please enter preset name', along with a 'Favorite preset' toggle and buttons for 'Save', 'Save & Apply', 'Preview', and 'Reset'. The main area shows a routing matrix with the following structure:

Cluster info.		Stereo 2.0		Stereo 2.1		Stereo 2.2		Stereo 2.3		Stereo 2.4		Stereo 2.5		Stereo 2.6		Stereo 2.8		Volume Control	Headphone Inversion	Main on Mute	Solo Mute	Speaker Mute
L	R	L	R	L	R	L	R	L	R	L	R	L	R	L	R	L	R					
Input Gain (dB)		9	9	9	9	9	9	9	9	9	9	9	9	9	9	9	9					
Meter #		1	2	3	4	5	6	7	8	9	10	11	12	13	14	15	16					
Speaker Headphone		L 1	L 2	L 3	L 4	L 5	L 6	L 7	L 8	L 9	L 10	L 11	L 12	L 13	L 14	L 15	L 16	<input checked="" type="checkbox"/>	<input checked="" type="checkbox"/>	<input checked="" type="checkbox"/>	<input checked="" type="checkbox"/>	<input checked="" type="checkbox"/>
Analog / XLR		L 1	L 2	L 3	L 4	L 5	L 6	L 7	L 8	L 9	L 10	L 11	L 12	L 13	L 14	L 15	L 16	<input checked="" type="checkbox"/>	<input type="checkbox"/>	<input checked="" type="checkbox"/>	<input checked="" type="checkbox"/>	<input checked="" type="checkbox"/>
Analog / DB25/ Pair-1		L 1	L 2	L 3	L 4	L 5	L 6	L 7	L 8	L 9	L 10	L 11	L 12	L 13	L 14	L 15	L 16	<input checked="" type="checkbox"/>	<input type="checkbox"/>	<input checked="" type="checkbox"/>	<input type="checkbox"/>	<input type="checkbox"/>
Analog / DB25/ Pair-2		L 3	L 4	L 5	L 6	L 7	L 8	L 9	L 10	L 11	L 12	L 13	L 14	L 15	L 16	L 17	L 18	<input checked="" type="checkbox"/>	<input type="checkbox"/>	<input checked="" type="checkbox"/>	<input type="checkbox"/>	<input type="checkbox"/>
Analog / DB25/ Pair-3		L 5	L 6	L 7	L 8	L 9	L 10	L 11	L 12	L 13	L 14	L 15	L 16	L 17	L 18	L 19	L 20	<input checked="" type="checkbox"/>	<input type="checkbox"/>	<input checked="" type="checkbox"/>	<input type="checkbox"/>	<input type="checkbox"/>
Analog / DB25/ Pair-4		L 7	L 8	L 9	L 10	L 11	L 12	L 13	L 14	L 15	L 16	L 17	L 18	L 19	L 20	L 21	L 22	<input checked="" type="checkbox"/>	<input type="checkbox"/>	<input checked="" type="checkbox"/>	<input type="checkbox"/>	<input type="checkbox"/>
Analog / DB25/ Pair-5		L 9	L 10	L 11	L 12	L 13	L 14	L 15	L 16	L 17	L 18	L 19	L 20	L 21	L 22	L 23	L 24	<input checked="" type="checkbox"/>	<input type="checkbox"/>	<input checked="" type="checkbox"/>	<input type="checkbox"/>	<input type="checkbox"/>
Analog / DB25/ Pair-6		L 11	L 12	L 13	L 14	L 15	L 16	L 17	L 18	L 19	L 20	L 21	L 22	L 23	L 24	L 25	L 26	<input checked="" type="checkbox"/>	<input type="checkbox"/>	<input checked="" type="checkbox"/>	<input type="checkbox"/>	<input type="checkbox"/>
Analog / DB25/ Pair-7		L 13	L 14	L 15	L 16	L 17	L 18	L 19	L 20	L 21	L 22	L 23	L 24	L 25	L 26	L 27	L 28	<input checked="" type="checkbox"/>	<input type="checkbox"/>	<input checked="" type="checkbox"/>	<input type="checkbox"/>	<input type="checkbox"/>
Analog / DB25/ Pair-8		L 15	L 16	L 17	L 18	L 19	L 20	L 21	L 22	L 23	L 24	L 25	L 26	L 27	L 28	L 29	L 30	<input checked="" type="checkbox"/>	<input type="checkbox"/>	<input checked="" type="checkbox"/>	<input type="checkbox"/>	<input type="checkbox"/>
VIDEO OUT SDI/ Pair-1		L 1	L 2	L 3	L 4	L 5	L 6	L 7	L 8	L 9	L 10	L 11	L 12	L 13	L 14	L 15	L 16	<input type="checkbox"/>	<input type="checkbox"/>	<input type="checkbox"/>	<input type="checkbox"/>	<input type="checkbox"/>
VIDEO OUT SDI/ Pair-2		L 3	L 4	L 5	L 6	L 7	L 8	L 9	L 10	L 11	L 12	L 13	L 14	L 15	L 16	L 17	L 18	<input type="checkbox"/>	<input type="checkbox"/>	<input type="checkbox"/>	<input type="checkbox"/>	<input type="checkbox"/>
VIDEO OUT SDI/ Pair-3		L 5	L 6	L 7	L 8	L 9	L 10	L 11	L 12	L 13	L 14	L 15	L 16	L 17	L 18	L 19	L 20	<input type="checkbox"/>	<input type="checkbox"/>	<input type="checkbox"/>	<input type="checkbox"/>	<input type="checkbox"/>
VIDEO OUT SDI/ Pair-4		L 7	L 8	L 9	L 10	L 11	L 12	L 13	L 14	L 15	L 16	L 17	L 18	L 19	L 20	L 21	L 22	<input type="checkbox"/>	<input type="checkbox"/>	<input type="checkbox"/>	<input type="checkbox"/>	<input type="checkbox"/>

Copyright © 2019-2021 Wohler Technologies, Inc. All rights reserved.

When you have finished creating a Preset or making changes to a Preset, either click the **Save** button to save the Preset, click the **Save & Apply** button to save the Preset and make it the current Preset, or click the **Reset** button to discard the changes just made. These selections are shown in Figure 4-17.

Output Routing

The **Output Routing** feature (OPT-OUTPUT-ROUTING) allows channels to be routed or combined and routed in custom ways to various destination outputs. **Output Routing** is applied to:

1. Signals monitored using "Input Source select" from the Front Panel,
2. Presets that have been created to apply the Output Routing.

Any change to the routing will affect the Presets that have "Apply Output Routing" selected. For example, multiple channels of a 7.1 channel program can be combined and directed to the left or right internal speakers. Six or eight channels could be directed to the Balanced Analog Outputs, which could feed an external surround sound system.

By default, any of the inputs can be monitored in stereo or mono only through the internal speakers. The headphone jack and the analog XLR outputs will follow whatever is directed to the speakers. By default, all the outputs except for speakers are configured to not mute when the headphone is inserted into its jack. However, using the checkboxes in the Mute on Headphone Insertion column, you may change which outputs get muted.

To change the routing of inputs to outputs, select **Global Output Routing** under **Configuration** will display the **Global Output Routing** screen shown in Figure 4-18. This screen contains a matrix of checkboxes which are an easy way for you to set up the wide variety of input to output routing and mixing capabilities.

Figure 4-18: Global Output Routing Option

Destination Outputs *Source Inputs* *Output Options*

Cluster info.		Stereo 2.0		Stereo 2.0		Stereo 2.0		Stereo 2.0		Stereo 2.0		Stereo 2.0		Stereo 2.0		Volume Control	Mute on Headphone Insertion	Solo Mute	Speaker Mix
Speaker assign.		L	R	L	R	L	R	L	R	L	R	L	R						
Input Gain (dB)		0	0	0	0	0	0	0	0	0	0	0	0	0					
Meter #		1	2	3	4	5	6	7	8	9	10	11	12	13	14	15	16		
Speaker Headphone	L	1	<input checked="" type="checkbox"/>	<input checked="" type="checkbox"/>	<input checked="" type="checkbox"/>	<input checked="" type="checkbox"/>	<input checked="" type="checkbox"/>	<input checked="" type="checkbox"/>	<input checked="" type="checkbox"/>	<input checked="" type="checkbox"/>	<input checked="" type="checkbox"/>	<input checked="" type="checkbox"/>	<input checked="" type="checkbox"/>	<input checked="" type="checkbox"/>	<input checked="" type="checkbox"/>	<input checked="" type="checkbox"/>	<input checked="" type="checkbox"/>	<input checked="" type="checkbox"/>	<input checked="" type="checkbox"/>
	R	2	<input checked="" type="checkbox"/>	<input checked="" type="checkbox"/>	<input checked="" type="checkbox"/>	<input checked="" type="checkbox"/>	<input checked="" type="checkbox"/>	<input checked="" type="checkbox"/>	<input checked="" type="checkbox"/>	<input checked="" type="checkbox"/>	<input checked="" type="checkbox"/>	<input checked="" type="checkbox"/>	<input checked="" type="checkbox"/>	<input checked="" type="checkbox"/>	<input checked="" type="checkbox"/>	<input checked="" type="checkbox"/>	<input checked="" type="checkbox"/>	<input checked="" type="checkbox"/>	<input checked="" type="checkbox"/>
Analog / XLR	L	1	<input checked="" type="checkbox"/>	<input checked="" type="checkbox"/>	<input checked="" type="checkbox"/>	<input checked="" type="checkbox"/>	<input checked="" type="checkbox"/>	<input checked="" type="checkbox"/>	<input checked="" type="checkbox"/>	<input checked="" type="checkbox"/>	<input checked="" type="checkbox"/>	<input checked="" type="checkbox"/>	<input checked="" type="checkbox"/>	<input checked="" type="checkbox"/>	<input checked="" type="checkbox"/>	<input checked="" type="checkbox"/>	<input checked="" type="checkbox"/>	<input checked="" type="checkbox"/>	<input checked="" type="checkbox"/>
	R	2	<input checked="" type="checkbox"/>	<input checked="" type="checkbox"/>	<input checked="" type="checkbox"/>	<input checked="" type="checkbox"/>	<input checked="" type="checkbox"/>	<input checked="" type="checkbox"/>	<input checked="" type="checkbox"/>	<input checked="" type="checkbox"/>	<input checked="" type="checkbox"/>	<input checked="" type="checkbox"/>	<input checked="" type="checkbox"/>	<input checked="" type="checkbox"/>	<input checked="" type="checkbox"/>	<input checked="" type="checkbox"/>	<input checked="" type="checkbox"/>	<input checked="" type="checkbox"/>	<input checked="" type="checkbox"/>
Analog / DB25/ Pair-1	L	1	<input checked="" type="checkbox"/>	<input type="checkbox"/>	<input type="checkbox"/>	<input type="checkbox"/>	<input type="checkbox"/>	<input type="checkbox"/>	<input type="checkbox"/>	<input type="checkbox"/>	<input type="checkbox"/>	<input type="checkbox"/>	<input type="checkbox"/>	<input type="checkbox"/>	<input type="checkbox"/>	<input type="checkbox"/>	<input type="checkbox"/>	<input checked="" type="checkbox"/>	<input type="checkbox"/>
	R	2	<input type="checkbox"/>	<input checked="" type="checkbox"/>	<input type="checkbox"/>	<input type="checkbox"/>	<input type="checkbox"/>	<input type="checkbox"/>	<input type="checkbox"/>	<input type="checkbox"/>	<input type="checkbox"/>	<input type="checkbox"/>	<input type="checkbox"/>	<input type="checkbox"/>	<input type="checkbox"/>	<input type="checkbox"/>	<input type="checkbox"/>	<input checked="" type="checkbox"/>	<input type="checkbox"/>
Analog / DB25/ Pair-2	L	3	<input type="checkbox"/>	<input checked="" type="checkbox"/>	<input type="checkbox"/>	<input type="checkbox"/>	<input type="checkbox"/>	<input type="checkbox"/>	<input type="checkbox"/>	<input type="checkbox"/>	<input type="checkbox"/>	<input type="checkbox"/>	<input type="checkbox"/>	<input type="checkbox"/>	<input type="checkbox"/>	<input type="checkbox"/>	<input type="checkbox"/>	<input checked="" type="checkbox"/>	<input type="checkbox"/>
	R	4	<input type="checkbox"/>	<input type="checkbox"/>	<input checked="" type="checkbox"/>	<input type="checkbox"/>	<input type="checkbox"/>	<input type="checkbox"/>	<input type="checkbox"/>	<input type="checkbox"/>	<input type="checkbox"/>	<input type="checkbox"/>	<input type="checkbox"/>	<input type="checkbox"/>	<input type="checkbox"/>	<input type="checkbox"/>	<input type="checkbox"/>	<input checked="" type="checkbox"/>	<input type="checkbox"/>
Analog / DB25/ Pair-3	L	5	<input type="checkbox"/>	<input type="checkbox"/>	<input checked="" type="checkbox"/>	<input type="checkbox"/>	<input type="checkbox"/>	<input type="checkbox"/>	<input type="checkbox"/>	<input type="checkbox"/>	<input type="checkbox"/>	<input type="checkbox"/>	<input type="checkbox"/>	<input type="checkbox"/>	<input type="checkbox"/>	<input type="checkbox"/>	<input type="checkbox"/>	<input checked="" type="checkbox"/>	<input type="checkbox"/>
	R	6	<input type="checkbox"/>	<input type="checkbox"/>	<input type="checkbox"/>	<input checked="" type="checkbox"/>	<input type="checkbox"/>	<input type="checkbox"/>	<input type="checkbox"/>	<input type="checkbox"/>	<input type="checkbox"/>	<input type="checkbox"/>	<input type="checkbox"/>	<input type="checkbox"/>	<input type="checkbox"/>	<input type="checkbox"/>	<input type="checkbox"/>	<input checked="" type="checkbox"/>	<input type="checkbox"/>
Analog / DB25/ Pair-4	L	7	<input type="checkbox"/>	<input type="checkbox"/>	<input type="checkbox"/>	<input type="checkbox"/>	<input checked="" type="checkbox"/>	<input type="checkbox"/>	<input type="checkbox"/>	<input type="checkbox"/>	<input type="checkbox"/>	<input type="checkbox"/>	<input type="checkbox"/>	<input type="checkbox"/>	<input type="checkbox"/>	<input type="checkbox"/>	<input type="checkbox"/>	<input checked="" type="checkbox"/>	<input type="checkbox"/>
	R	8	<input type="checkbox"/>	<input type="checkbox"/>	<input type="checkbox"/>	<input type="checkbox"/>	<input type="checkbox"/>	<input checked="" type="checkbox"/>	<input type="checkbox"/>	<input type="checkbox"/>	<input type="checkbox"/>	<input type="checkbox"/>	<input type="checkbox"/>	<input type="checkbox"/>	<input type="checkbox"/>	<input type="checkbox"/>	<input type="checkbox"/>	<input checked="" type="checkbox"/>	<input type="checkbox"/>
Analog / DB25/ Pair-5	L	9	<input type="checkbox"/>	<input type="checkbox"/>	<input type="checkbox"/>	<input type="checkbox"/>	<input type="checkbox"/>	<input checked="" type="checkbox"/>	<input type="checkbox"/>	<input type="checkbox"/>	<input type="checkbox"/>	<input type="checkbox"/>	<input type="checkbox"/>	<input type="checkbox"/>	<input type="checkbox"/>	<input type="checkbox"/>	<input type="checkbox"/>	<input checked="" type="checkbox"/>	<input type="checkbox"/>
	R	10	<input type="checkbox"/>	<input type="checkbox"/>	<input type="checkbox"/>	<input type="checkbox"/>	<input type="checkbox"/>	<input type="checkbox"/>	<input checked="" type="checkbox"/>	<input type="checkbox"/>	<input type="checkbox"/>	<input type="checkbox"/>	<input type="checkbox"/>	<input type="checkbox"/>	<input type="checkbox"/>	<input type="checkbox"/>	<input type="checkbox"/>	<input checked="" type="checkbox"/>	<input type="checkbox"/>
Analog / DB25/ Pair-6	L	11	<input type="checkbox"/>	<input type="checkbox"/>	<input type="checkbox"/>	<input type="checkbox"/>	<input type="checkbox"/>	<input type="checkbox"/>	<input type="checkbox"/>	<input checked="" type="checkbox"/>	<input type="checkbox"/>	<input type="checkbox"/>	<input type="checkbox"/>	<input type="checkbox"/>	<input type="checkbox"/>	<input type="checkbox"/>	<input type="checkbox"/>	<input checked="" type="checkbox"/>	<input type="checkbox"/>
	R	12	<input type="checkbox"/>	<input type="checkbox"/>	<input type="checkbox"/>	<input type="checkbox"/>	<input type="checkbox"/>	<input type="checkbox"/>	<input type="checkbox"/>	<input type="checkbox"/>	<input checked="" type="checkbox"/>	<input type="checkbox"/>	<input type="checkbox"/>	<input type="checkbox"/>	<input type="checkbox"/>	<input type="checkbox"/>	<input type="checkbox"/>	<input checked="" type="checkbox"/>	<input type="checkbox"/>
Analog / DB25/ Pair-7	L	13	<input type="checkbox"/>	<input type="checkbox"/>	<input type="checkbox"/>	<input type="checkbox"/>	<input type="checkbox"/>	<input type="checkbox"/>	<input type="checkbox"/>	<input type="checkbox"/>	<input type="checkbox"/>	<input checked="" type="checkbox"/>	<input type="checkbox"/>	<input type="checkbox"/>	<input type="checkbox"/>	<input type="checkbox"/>	<input type="checkbox"/>	<input checked="" type="checkbox"/>	<input type="checkbox"/>
	R	14	<input type="checkbox"/>	<input type="checkbox"/>	<input type="checkbox"/>	<input type="checkbox"/>	<input type="checkbox"/>	<input type="checkbox"/>	<input type="checkbox"/>	<input type="checkbox"/>	<input type="checkbox"/>	<input type="checkbox"/>	<input checked="" type="checkbox"/>	<input type="checkbox"/>	<input type="checkbox"/>	<input type="checkbox"/>	<input type="checkbox"/>	<input checked="" type="checkbox"/>	<input type="checkbox"/>
Analog / DB25/ Pair-8	L	15	<input type="checkbox"/>	<input type="checkbox"/>	<input type="checkbox"/>	<input type="checkbox"/>	<input type="checkbox"/>	<input type="checkbox"/>	<input type="checkbox"/>	<input type="checkbox"/>	<input type="checkbox"/>	<input type="checkbox"/>	<input type="checkbox"/>	<input checked="" type="checkbox"/>	<input type="checkbox"/>	<input type="checkbox"/>	<input type="checkbox"/>	<input checked="" type="checkbox"/>	<input type="checkbox"/>
	R	16	<input type="checkbox"/>	<input type="checkbox"/>	<input type="checkbox"/>	<input type="checkbox"/>	<input type="checkbox"/>	<input type="checkbox"/>	<input type="checkbox"/>	<input type="checkbox"/>	<input type="checkbox"/>	<input type="checkbox"/>	<input type="checkbox"/>	<input type="checkbox"/>	<input checked="" type="checkbox"/>	<input type="checkbox"/>	<input type="checkbox"/>	<input checked="" type="checkbox"/>	<input type="checkbox"/>
VIDEO OUT SDI/ Pair-1	L	1	<input checked="" type="checkbox"/>	<input type="checkbox"/>	<input type="checkbox"/>	<input type="checkbox"/>	<input type="checkbox"/>	<input type="checkbox"/>	<input type="checkbox"/>	<input type="checkbox"/>	<input type="checkbox"/>	<input type="checkbox"/>	<input type="checkbox"/>	<input type="checkbox"/>	<input type="checkbox"/>	<input type="checkbox"/>	<input type="checkbox"/>	<input type="checkbox"/>	<input type="checkbox"/>
	R	2	<input type="checkbox"/>	<input checked="" type="checkbox"/>	<input type="checkbox"/>	<input type="checkbox"/>	<input type="checkbox"/>	<input type="checkbox"/>	<input type="checkbox"/>	<input type="checkbox"/>	<input type="checkbox"/>	<input type="checkbox"/>	<input type="checkbox"/>	<input type="checkbox"/>	<input type="checkbox"/>	<input type="checkbox"/>	<input type="checkbox"/>	<input type="checkbox"/>	<input type="checkbox"/>
VIDEO OUT SDI/ Pair-2	L	3	<input type="checkbox"/>	<input checked="" type="checkbox"/>	<input type="checkbox"/>	<input type="checkbox"/>	<input type="checkbox"/>	<input type="checkbox"/>	<input type="checkbox"/>	<input type="checkbox"/>	<input type="checkbox"/>	<input type="checkbox"/>	<input type="checkbox"/>	<input type="checkbox"/>	<input type="checkbox"/>	<input type="checkbox"/>	<input type="checkbox"/>	<input type="checkbox"/>	<input type="checkbox"/>
	R	4	<input type="checkbox"/>	<input type="checkbox"/>	<input checked="" type="checkbox"/>	<input type="checkbox"/>	<input type="checkbox"/>	<input type="checkbox"/>	<input type="checkbox"/>	<input type="checkbox"/>	<input type="checkbox"/>	<input type="checkbox"/>	<input type="checkbox"/>	<input type="checkbox"/>	<input type="checkbox"/>	<input type="checkbox"/>	<input type="checkbox"/>	<input type="checkbox"/>	<input type="checkbox"/>
VIDEO OUT SDI/ Pair-3	L	5	<input type="checkbox"/>	<input type="checkbox"/>	<input checked="" type="checkbox"/>	<input type="checkbox"/>	<input type="checkbox"/>	<input type="checkbox"/>	<input type="checkbox"/>	<input type="checkbox"/>	<input type="checkbox"/>	<input type="checkbox"/>	<input type="checkbox"/>	<input type="checkbox"/>	<input type="checkbox"/>	<input type="checkbox"/>	<input type="checkbox"/>	<input type="checkbox"/>	<input type="checkbox"/>
	R	6	<input type="checkbox"/>	<input type="checkbox"/>	<input type="checkbox"/>	<input checked="" type="checkbox"/>	<input type="checkbox"/>	<input type="checkbox"/>	<input type="checkbox"/>	<input type="checkbox"/>	<input type="checkbox"/>	<input type="checkbox"/>	<input type="checkbox"/>	<input type="checkbox"/>	<input type="checkbox"/>	<input type="checkbox"/>	<input type="checkbox"/>	<input type="checkbox"/>	<input type="checkbox"/>
VIDEO OUT SDI/ Pair-4	L	7	<input type="checkbox"/>	<input type="checkbox"/>	<input type="checkbox"/>	<input type="checkbox"/>	<input checked="" type="checkbox"/>	<input type="checkbox"/>	<input type="checkbox"/>	<input type="checkbox"/>	<input type="checkbox"/>	<input type="checkbox"/>	<input type="checkbox"/>	<input type="checkbox"/>	<input type="checkbox"/>	<input type="checkbox"/>	<input type="checkbox"/>	<input type="checkbox"/>	<input type="checkbox"/>
	R	8	<input type="checkbox"/>	<input type="checkbox"/>	<input type="checkbox"/>	<input type="checkbox"/>	<input type="checkbox"/>	<input checked="" type="checkbox"/>	<input type="checkbox"/>	<input type="checkbox"/>	<input type="checkbox"/>	<input type="checkbox"/>	<input type="checkbox"/>	<input type="checkbox"/>	<input type="checkbox"/>	<input type="checkbox"/>	<input type="checkbox"/>	<input type="checkbox"/>	<input type="checkbox"/>

Destination Outputs

On the left of the **Global Output Routing** screen are listed the Destination Outputs. These are the outputs to which any input can be routed. They are as follows:

1. **Speaker/Headphone:** Selected inputs will be sent to the left and right speakers. The default routing is set as per the Speaker Assignment, left channels are sent to the left speaker and right channels are sent to the Right speaker.
2. **Analog XLR:** Selected inputs will be mixed to the left and right channels and played through the two Analog XLR Outputs. By default, these outputs will follow the speaker assignments. These outputs are not muted upon Headphone insertion.
3. **Analog DB-25 Outputs 1 to 16:** Selected inputs will be sent to the 16 channel outputs of the Analog DB-25 connector on the rear panel.
4. **Video Out SDI Pair 1 to Video Out SDI Pair-4:** Selected inputs of your choice will be sent to the first 8 of the 16 SDI audio channels of the SFP slot on the rear panel. The sources appearing on meters 9 though 16 are sent to

SDI output channels 9 through 16 and that is not configurable.

Source Inputs

The source inputs which may be routed are described in this section.

1. **Cluster Information:** Cluster information shows the type of cluster and the cluster name.
2. **Speaker Assignment:** Speaker assignment can be used to configure to which speakers the audio is routed to. The possible options are:
 - L** Left
 - R** Right
 - C** Center
 - LFE** Low Frequency Effects
 - Ls** Left Surround
 - Rs** Right Surround
 - Bsl** Back Surround Left
 - Bsr** Back Surround Right
 - S** Mono Surround
3. **Input/Output Matrix:** By checking the various boxes in this matrix, any input channels can be freely routed to any output channels. This flexible channel assignment is called a **Free Mix**. However, when the **Speaker Mix** box is checked in the **Output Options** section, the associated row within the matrix is automatically set to the speaker mix and the checkboxes are grayed out indicating that you may not change them with a **Free Mix** assignment.

Output Options

The optional settings in this section allow for customization.

1. **Speaker Mix:** This option selects whether an output has the **Speaker Mix** or a **Free Mix** as set in the Routing Input section. The Speaker/Headphone output is always in the **Speaker Mix**.
2. **Solo/Mute:** This setting determines whether or not the outputs are affected by solos and mutes. The Speaker/Headphone output is always affected by solos and mutes. Note also, that all outputs in **Speaker Mix** mode also are affected by solos and mutes.
3. **Mute on Headphone Insertion:** This option controls whether the outputs should be muted upon a headphone insertion. This setting can be adjusted even for outputs whether they are in **Speaker Mix** or **Free Mix** modes.
4. **Volume Control:** This setting determines whether each output pair is adjusted by the **Volume Control** knob. Speaker/Headphone outputs are always affected by the **Volume Control** knob, as are any outputs that are in **Speaker Mix** mode.

Typical Questions Regarding Output Routing

The questions and thoughts in this section are commonly asked by people when setting up the Output Routing capability.

What signal outputs can be controlled using the Output Routing feature?

All the outputs on the iAM-12G-SDI can be controlled using the Output Routing feature. This includes – Internal Speakers, Analog XLR outputs, all 8 pairs of Analog DB25 outputs and 4 pairs of SDI SFP outputs.

How do the outputs behave in their factory default settings?

By default, the outputs are configured as follows:

1. **Speakers:** All monitored channels are always available on the internal speakers. The left and right speaker assignment is determined by the **Speaker Assignment**. Audio on the speakers is controlled by the **Volume** and **Balance** knobs and is muted whenever a headphone is inserted into the **Headphone** jack.
2. **Analog XLRs:** These outputs follow the same configuration as the internal speakers. They are controlled by the **Volume** and **Balance** knobs. These outputs also follow the solo/mute selections on the Audio Meter screen. The Analog XLR outputs by default do not mute with headphone insertion.
3. **Analog Pairs 1 through 8:** The 16 monitored channels will appear on these outputs in numeric order. By default, the audio levels on this output are controlled by the **Volume** and **Balance** knobs and also follow the solo/mutes from the Audio Meter screen.
4. **SDI Pairs 1 through 4:** The first 8 monitored channels will appear on these outputs in numeric order. By default these outputs are in pre-fade mode. They are not controlled by the **Volume** or **Balance** knobs and do not follow the mute/unmute selections on the Audio Meter screen. The remaining 4 pairs of SDI outputs always follow the last 4 pairs of the monitored channels and cannot be configured using the output routing feature.

What is the difference between Global Output Routing and Output Routing in Presets?

Both are used to configure the unit outputs. Global Output Routing is applied by default when you select a source or when creating presets and when you don't change the Output Routing to be unique to any Preset.

How do I route whatever is being monitored to the Analog XLR outputs?

Using **Global Output Routing**, you may route any signals using the Analog/XLR

checkboxes.

Cluster info.		Stereo 2.0		Stereo 2.0		Stereo 2.0		Stereo 2.0		Stereo 2.0		Stereo 2.0		Stereo 2.0		Stereo 2.0		Volume Control	Headphone Insertion	Mute on Headphone Mute	Solo Mute	Speaker Mix
Speaker assig.		L	R	L	R	L	R	L	R	L	R	L	R	L	R	L	R					
Input Gain (dB)		0	0	0	0	0	0	0	0	0	0	0	0	0	0	0	0					
Meter #		1	2	3	4	5	6	7	8	9	10	11	12	13	14	15	16					
Analog / XLR	L	1	<input checked="" type="checkbox"/>	<input type="checkbox"/>	<input type="checkbox"/>	<input type="checkbox"/>	<input type="checkbox"/>	<input type="checkbox"/>	<input type="checkbox"/>	<input type="checkbox"/>	<input type="checkbox"/>	<input type="checkbox"/>	<input type="checkbox"/>	<input type="checkbox"/>	<input type="checkbox"/>	<input type="checkbox"/>	<input type="checkbox"/>	<input checked="" type="checkbox"/>	<input type="checkbox"/>	<input checked="" type="checkbox"/>	<input type="checkbox"/>	<input type="checkbox"/>
	R	2	<input type="checkbox"/>	<input checked="" type="checkbox"/>	<input type="checkbox"/>	<input type="checkbox"/>	<input type="checkbox"/>	<input type="checkbox"/>	<input type="checkbox"/>	<input type="checkbox"/>	<input type="checkbox"/>	<input type="checkbox"/>	<input type="checkbox"/>	<input type="checkbox"/>	<input type="checkbox"/>	<input type="checkbox"/>	<input type="checkbox"/>	<input type="checkbox"/>	<input type="checkbox"/>	<input type="checkbox"/>	<input type="checkbox"/>	<input type="checkbox"/>

As shown in the above example, signals appearing on Audio Meter channels 1 and 2 are routed to the Analog XLR outputs. This output is volume and balance controlled and will follow the Solo/Mutes on the Audio Meter screen.

How do I have a downmixed pre-fade output on Analog DB-25 Pair-1 combined with a post-fade output on the Analog XLRs?

To control whether a specific output is pre-faded or post-faded use the **Volume Control** setting on the Output Routing configuration page.

Cluster info.		Stereo 2.0		Stereo 2.0		Stereo 2.0		Stereo 2.0		Stereo 2.0		Stereo 2.0		Stereo 2.0		Stereo 2.0		Volume Control
Speaker assig.		L	R	L	R	L	R	L	R	L	R	L	R	L	R	L	R	
Input Gain (dB)		0	0	0	0	0	0	0	0	0	0	0	0	0	0	0	0	
Meter #		1	2	3	4	5	6	7	8	9	10	11	12	13	14	15	16	
Analog / XLR	L	1	<input checked="" type="checkbox"/>	<input type="checkbox"/>	<input checked="" type="checkbox"/>	<input type="checkbox"/>	<input checked="" type="checkbox"/>	<input type="checkbox"/>	<input checked="" type="checkbox"/>	<input type="checkbox"/>	<input checked="" type="checkbox"/>	<input type="checkbox"/>	<input checked="" type="checkbox"/>	<input type="checkbox"/>	<input checked="" type="checkbox"/>	<input type="checkbox"/>	<input checked="" type="checkbox"/>	<input checked="" type="checkbox"/>
	R	2	<input type="checkbox"/>	<input checked="" type="checkbox"/>	<input type="checkbox"/>	<input checked="" type="checkbox"/>	<input type="checkbox"/>	<input checked="" type="checkbox"/>	<input type="checkbox"/>	<input checked="" type="checkbox"/>	<input type="checkbox"/>	<input checked="" type="checkbox"/>	<input type="checkbox"/>	<input checked="" type="checkbox"/>	<input type="checkbox"/>	<input checked="" type="checkbox"/>	<input type="checkbox"/>	<input type="checkbox"/>
Analog / DB25/ Pair-1	L	1	<input checked="" type="checkbox"/>	<input checked="" type="checkbox"/>	<input type="checkbox"/>	<input checked="" type="checkbox"/>	<input type="checkbox"/>	<input checked="" type="checkbox"/>	<input type="checkbox"/>	<input checked="" type="checkbox"/>	<input type="checkbox"/>	<input checked="" type="checkbox"/>	<input type="checkbox"/>	<input checked="" type="checkbox"/>	<input type="checkbox"/>	<input checked="" type="checkbox"/>	<input type="checkbox"/>	<input type="checkbox"/>
	R	2	<input checked="" type="checkbox"/>	<input type="checkbox"/>	<input checked="" type="checkbox"/>	<input type="checkbox"/>	<input checked="" type="checkbox"/>	<input type="checkbox"/>	<input checked="" type="checkbox"/>	<input type="checkbox"/>	<input checked="" type="checkbox"/>	<input type="checkbox"/>	<input checked="" type="checkbox"/>	<input type="checkbox"/>	<input checked="" type="checkbox"/>	<input type="checkbox"/>	<input checked="" type="checkbox"/>	<input type="checkbox"/>

Volume Control:
 On - Post-fade
 Off - Pre-fade

In the settings shown above, the Analog XLRs as well as the Analog DB-25 Pair-1 outputs will have a downmix of whatever is being monitored, however the XLR outputs will be post-fade and DB-25 Pair-1 output will be pre-fade.

How do I make the XLR outputs follow the Audio Meter screen Solos and Mutes while the Analog DB-25 Pair-1 does not?

When Make the settings shown in the **Solo / Mute** column:

Cluster info.		Stereo 2.0		Stereo 2.0		Stereo 2.0		Stereo 2.0		Stereo 2.0		Stereo 2.0		Stereo 2.0		Stereo 2.0		Volume Control	Headphone Insertion	Mute on Headphone Mute	Solo Mute
Speaker assig.		L	R	L	R	L	R	L	R	L	R	L	R	L	R	L	R				
Input Gain (dB)		0	0	0	0	0	0	0	0	0	0	0	0	0	0	0	0				
Meter #		1	2	3	4	5	6	7	8	9	10	11	12	13	14	15	16				
Analog / XLR	L	1	<input checked="" type="checkbox"/>	<input checked="" type="checkbox"/>	<input checked="" type="checkbox"/>	<input checked="" type="checkbox"/>	<input checked="" type="checkbox"/>	<input checked="" type="checkbox"/>	<input checked="" type="checkbox"/>	<input checked="" type="checkbox"/>	<input checked="" type="checkbox"/>	<input checked="" type="checkbox"/>	<input checked="" type="checkbox"/>	<input checked="" type="checkbox"/>	<input checked="" type="checkbox"/>	<input checked="" type="checkbox"/>	<input checked="" type="checkbox"/>	<input checked="" type="checkbox"/>	<input checked="" type="checkbox"/>	<input checked="" type="checkbox"/>	<input checked="" type="checkbox"/>
	R	2	<input checked="" type="checkbox"/>	<input checked="" type="checkbox"/>	<input checked="" type="checkbox"/>	<input checked="" type="checkbox"/>	<input checked="" type="checkbox"/>	<input checked="" type="checkbox"/>	<input checked="" type="checkbox"/>	<input checked="" type="checkbox"/>	<input checked="" type="checkbox"/>	<input checked="" type="checkbox"/>	<input checked="" type="checkbox"/>	<input checked="" type="checkbox"/>	<input checked="" type="checkbox"/>	<input checked="" type="checkbox"/>	<input checked="" type="checkbox"/>	<input checked="" type="checkbox"/>	<input checked="" type="checkbox"/>	<input checked="" type="checkbox"/>	<input checked="" type="checkbox"/>
Analog / DB25/ Pair-1	L	1	<input checked="" type="checkbox"/>	<input type="checkbox"/>	<input type="checkbox"/>	<input type="checkbox"/>	<input type="checkbox"/>	<input type="checkbox"/>	<input type="checkbox"/>	<input type="checkbox"/>	<input type="checkbox"/>	<input type="checkbox"/>	<input type="checkbox"/>	<input type="checkbox"/>	<input type="checkbox"/>	<input type="checkbox"/>	<input type="checkbox"/>	<input type="checkbox"/>	<input checked="" type="checkbox"/>	<input type="checkbox"/>	<input type="checkbox"/>
	R	2	<input checked="" type="checkbox"/>	<input type="checkbox"/>	<input type="checkbox"/>	<input type="checkbox"/>	<input type="checkbox"/>	<input type="checkbox"/>	<input type="checkbox"/>	<input type="checkbox"/>	<input type="checkbox"/>	<input type="checkbox"/>	<input type="checkbox"/>	<input type="checkbox"/>	<input type="checkbox"/>	<input type="checkbox"/>	<input type="checkbox"/>	<input type="checkbox"/>	<input checked="" type="checkbox"/>	<input type="checkbox"/>	<input type="checkbox"/>

Solo Mute:
 On - Outputs follow user Solo/Mute
 Off - Outputs do not follow user Solo/Mutes

The setting shown above determines that outputs will follow the Audio Meter screen solos & mutes for the XLR outputs because the checkbox is checked. It is not checked for Analog DB25 Pair 1, so that will not be affected by the solo & mute choices.

The Global Output Routing feature works great. But what if we don't want to create any Presets and want to monitor audio only using Source Select? How would I configure different outputs for Source Select choices?

Use the **Global Output Routing** settings to determine how the outputs are configured for source select options.

How do I keep the internal speakers muted and have audio only on the analog XLR outputs?

In the **Global Output Routing** configuration, do not select any **Speaker Headphone** checkboxes for any meter channels as shown below, and then select the desired meters for Analog XLR. In this way, the internal speakers will always be muted, but the audio will appear on the Analog XLR outputs (for amplified external speakers). Make sure that the **Speaker Mix** checkbox selection is unchecked for Analog/XLR.

Cluster info.		Stereo 2.0		Stereo 2.0		Stereo 2.0		Stereo 2.0		Stereo 2.0		Stereo 2.0		Stereo 2.0		Volume Control	Mute on Headphone Insertion	Solo Mute	Speaker Mix
Speaker assign.		L	R	L	R	L	R	L	R	L	R	L	R	L	R				
Input Gain (dB)		0	0	0	0	0	0	0	0	0	0	0	0	0	0				
Meter #		1	2	3	4	5	6	7	8	9	10	11	12	13	14	15	16		
Speaker Headphone	L	1	<input type="checkbox"/>	<input type="checkbox"/>	<input type="checkbox"/>	<input type="checkbox"/>	<input type="checkbox"/>	<input type="checkbox"/>	<input type="checkbox"/>	<input type="checkbox"/>	<input type="checkbox"/>	<input type="checkbox"/>	<input type="checkbox"/>	<input type="checkbox"/>	<input type="checkbox"/>	<input type="checkbox"/>	<input checked="" type="checkbox"/>	<input checked="" type="checkbox"/>	<input checked="" type="checkbox"/>
	R	2	<input type="checkbox"/>	<input type="checkbox"/>	<input type="checkbox"/>	<input type="checkbox"/>	<input type="checkbox"/>	<input type="checkbox"/>	<input type="checkbox"/>	<input type="checkbox"/>	<input type="checkbox"/>	<input type="checkbox"/>	<input type="checkbox"/>	<input type="checkbox"/>	<input type="checkbox"/>	<input type="checkbox"/>	<input checked="" type="checkbox"/>	<input checked="" type="checkbox"/>	<input checked="" type="checkbox"/>
Analog / XLR	L	1	<input checked="" type="checkbox"/>	<input checked="" type="checkbox"/>	<input checked="" type="checkbox"/>	<input checked="" type="checkbox"/>	<input checked="" type="checkbox"/>	<input checked="" type="checkbox"/>	<input checked="" type="checkbox"/>	<input checked="" type="checkbox"/>	<input checked="" type="checkbox"/>	<input checked="" type="checkbox"/>	<input checked="" type="checkbox"/>	<input checked="" type="checkbox"/>	<input checked="" type="checkbox"/>	<input checked="" type="checkbox"/>	<input checked="" type="checkbox"/>	<input checked="" type="checkbox"/>	<input type="checkbox"/>
	R	2	<input checked="" type="checkbox"/>	<input checked="" type="checkbox"/>	<input checked="" type="checkbox"/>	<input checked="" type="checkbox"/>	<input checked="" type="checkbox"/>	<input checked="" type="checkbox"/>	<input checked="" type="checkbox"/>	<input checked="" type="checkbox"/>	<input checked="" type="checkbox"/>	<input checked="" type="checkbox"/>	<input checked="" type="checkbox"/>	<input checked="" type="checkbox"/>	<input checked="" type="checkbox"/>	<input checked="" type="checkbox"/>	<input checked="" type="checkbox"/>	<input checked="" type="checkbox"/>	<input type="checkbox"/>

How do I ensure that the outputs are automatically muted when the Headphone jack is inserted?

In the **Global Output Routing** configuration, if the **Mute on Headphone Insertion** checkbox is ON then the outputs get automatically muted when a headphone is inserted into the Headphone jack.

Mute on Headphone Insertion:
On: Outputs are muted when Headphone Jack is inserted
Off: Outputs are not muted when Headphone Jack is inserted.

Cluster info.		Stereo 2.0		Stereo 2.0		Stereo 2.0		Stereo 2.0		Stereo 2.0		Stereo 2.0		Stereo 2.0		Volume Control	Mute on Headphone Insertion	Solo Mute	
Speaker assign.		L	R	L	R	L	R	L	R	L	R	L	R	L	R				
Input Gain (dB)		0	0	0	0	0	0	0	0	0	0	0	0	0	0				
Meter #		1	2	3	4	5	6	7	8	9	10	11	12	13	14	15	16		
Speaker Headphone	L	1	<input type="checkbox"/>	<input type="checkbox"/>	<input type="checkbox"/>	<input type="checkbox"/>	<input type="checkbox"/>	<input type="checkbox"/>	<input type="checkbox"/>	<input type="checkbox"/>	<input type="checkbox"/>	<input type="checkbox"/>	<input type="checkbox"/>	<input type="checkbox"/>	<input type="checkbox"/>	<input type="checkbox"/>	<input checked="" type="checkbox"/>	<input checked="" type="checkbox"/>	<input checked="" type="checkbox"/>
	R	2	<input type="checkbox"/>	<input type="checkbox"/>	<input type="checkbox"/>	<input type="checkbox"/>	<input type="checkbox"/>	<input type="checkbox"/>	<input type="checkbox"/>	<input type="checkbox"/>	<input type="checkbox"/>	<input type="checkbox"/>	<input type="checkbox"/>	<input type="checkbox"/>	<input type="checkbox"/>	<input type="checkbox"/>	<input checked="" type="checkbox"/>	<input checked="" type="checkbox"/>	<input checked="" type="checkbox"/>
Analog / XLR	L	1	<input checked="" type="checkbox"/>	<input checked="" type="checkbox"/>	<input checked="" type="checkbox"/>	<input checked="" type="checkbox"/>	<input checked="" type="checkbox"/>	<input checked="" type="checkbox"/>	<input checked="" type="checkbox"/>	<input checked="" type="checkbox"/>	<input checked="" type="checkbox"/>	<input checked="" type="checkbox"/>	<input checked="" type="checkbox"/>	<input checked="" type="checkbox"/>	<input checked="" type="checkbox"/>	<input checked="" type="checkbox"/>	<input checked="" type="checkbox"/>	<input checked="" type="checkbox"/>	<input type="checkbox"/>
	R	2	<input checked="" type="checkbox"/>	<input checked="" type="checkbox"/>	<input checked="" type="checkbox"/>	<input checked="" type="checkbox"/>	<input checked="" type="checkbox"/>	<input checked="" type="checkbox"/>	<input checked="" type="checkbox"/>	<input checked="" type="checkbox"/>	<input checked="" type="checkbox"/>	<input checked="" type="checkbox"/>	<input checked="" type="checkbox"/>	<input checked="" type="checkbox"/>	<input checked="" type="checkbox"/>	<input checked="" type="checkbox"/>	<input checked="" type="checkbox"/>	<input checked="" type="checkbox"/>	<input type="checkbox"/>
Analog / DB25/ Pair-1	L	1	<input checked="" type="checkbox"/>	<input type="checkbox"/>	<input type="checkbox"/>	<input type="checkbox"/>	<input type="checkbox"/>	<input type="checkbox"/>	<input type="checkbox"/>	<input type="checkbox"/>	<input type="checkbox"/>	<input type="checkbox"/>	<input type="checkbox"/>	<input type="checkbox"/>	<input type="checkbox"/>	<input type="checkbox"/>	<input type="checkbox"/>	<input type="checkbox"/>	<input type="checkbox"/>
	R	2	<input checked="" type="checkbox"/>	<input type="checkbox"/>	<input type="checkbox"/>	<input type="checkbox"/>	<input type="checkbox"/>	<input type="checkbox"/>	<input type="checkbox"/>	<input type="checkbox"/>	<input type="checkbox"/>	<input type="checkbox"/>	<input type="checkbox"/>	<input type="checkbox"/>	<input type="checkbox"/>	<input type="checkbox"/>	<input type="checkbox"/>	<input type="checkbox"/>	<input type="checkbox"/>

As shown above, if a headphone is inserted then the output on the internal speakers will be muted, while the audio on the Analog XLRs and Analog DB-25 Pair 1 will remain on.

How do I ensure that my outputs are pre-faded but follow the solo-mutes? This will allow us to monitor only the unmuted/solo Audio Meter channels on amplified stereo speakers connected to the Analog XLR's.

In the **Output Routing** setting, for the Analog XLR outputs, keep the **Volume Control** checkbox unchecked and the **Solo/Mute** checkbox checked. This ensures that the Volume Control is **not** applied to the outputs, while the Solos/Mutes **are**.

Cluster info.		Stereo 2.0		Stereo 2.0		Stereo 2.0		Stereo 2.0		Stereo 2.0		Stereo 2.0		Stereo 2.0		Volume Control	Mute on Headphone Insertion	Solo Mute	Speaker Mix
Speaker assign.		L	R	L	R	L	R	L	R	L	R	L	R						
Input Gain (dB)		0	0	0	0	0	0	0	0	0	0	0	0						
Meter #		1	2	3	4	5	6	7	8	9	10	11	12	13	14				
Speaker Headphone	L 1	<input type="checkbox"/>	<input type="checkbox"/>	<input type="checkbox"/>	<input type="checkbox"/>	<input type="checkbox"/>	<input type="checkbox"/>	<input type="checkbox"/>	<input type="checkbox"/>	<input type="checkbox"/>	<input type="checkbox"/>	<input type="checkbox"/>	<input type="checkbox"/>	<input type="checkbox"/>	<input type="checkbox"/>	<input checked="" type="checkbox"/>	<input checked="" type="checkbox"/>	<input checked="" type="checkbox"/>	<input checked="" type="checkbox"/>
	R 2	<input type="checkbox"/>	<input type="checkbox"/>	<input type="checkbox"/>	<input type="checkbox"/>	<input type="checkbox"/>	<input type="checkbox"/>	<input type="checkbox"/>	<input type="checkbox"/>	<input type="checkbox"/>	<input type="checkbox"/>	<input type="checkbox"/>	<input type="checkbox"/>	<input type="checkbox"/>	<input type="checkbox"/>	<input type="checkbox"/>	<input checked="" type="checkbox"/>	<input checked="" type="checkbox"/>	<input checked="" type="checkbox"/>
Analog / XLR	L 1	<input checked="" type="checkbox"/>	<input type="checkbox"/>	<input type="checkbox"/>	<input type="checkbox"/>	<input type="checkbox"/>	<input type="checkbox"/>	<input type="checkbox"/>	<input type="checkbox"/>	<input type="checkbox"/>	<input type="checkbox"/>	<input type="checkbox"/>	<input type="checkbox"/>	<input type="checkbox"/>	<input type="checkbox"/>	<input type="checkbox"/>	<input type="checkbox"/>	<input checked="" type="checkbox"/>	<input type="checkbox"/>
	R 2	<input type="checkbox"/>	<input checked="" type="checkbox"/>	<input type="checkbox"/>	<input type="checkbox"/>	<input type="checkbox"/>	<input type="checkbox"/>	<input type="checkbox"/>	<input type="checkbox"/>	<input type="checkbox"/>	<input type="checkbox"/>	<input type="checkbox"/>	<input type="checkbox"/>	<input type="checkbox"/>	<input type="checkbox"/>	<input type="checkbox"/>	<input type="checkbox"/>	<input checked="" type="checkbox"/>	<input type="checkbox"/>

Preset Replication

Preset Replication allows you to copy presets from a master unit to multiple iAM-12G-SDI units. This can save a lot of setup time if multiple units all need basically the same setup.

To start Preset Replication, click on the **Preset Replication** tab on the master unit. This will start the unit discovery process and will list all the iAM-12G-SDI units that you currently have on your network. The discovery process will continue for a period of 2 minutes. However, you may stop the discovery process sooner if you believe all the units in the network have been discovered. Simply click the **Stop Scan** button.

Figure 4-19: Preset Replication Scanning Screen

The screenshot shows the 'Preset Replication' interface. At the top, it says 'Scanning...' and 'Time remaining 42 seconds out of 120 seconds.' Below this is a circular progress indicator and a 'Stop Scan' button. A table below shows the following data:

#	Name	Serial	Model	System Version	IP Address	Preset Version
1	iAM-12G-SDI	162347	iAM-12G-SDI	1.8.11	10.11.11.16	4
2	iAM-12G-SDI	163173	iAM-12G-SDI	1.8.10	10.11.11.56	2
3	iAM-12G-SDI	163166	iAM-12G-SDI	1.8.11	10.11.11.9	4
4	iAM-12G-SDI	163175	iAM-12G-SDI	1.8.11	10.11.11.54	4
5	JV-iAM-12G	160597	iAM-12G-SDI	1.8.11	10.11.11.13	4

Once all the units are discovered you may either copy the presets that are currently created on the Master unit or can use an external preset file that you want to copy to any or all of the Target units. **Note that any and all of the Presets that may already be contained in each Target unit will be erased by copying the new Presets.**

Figure 4-18: Preset Replication Target Selection Screen

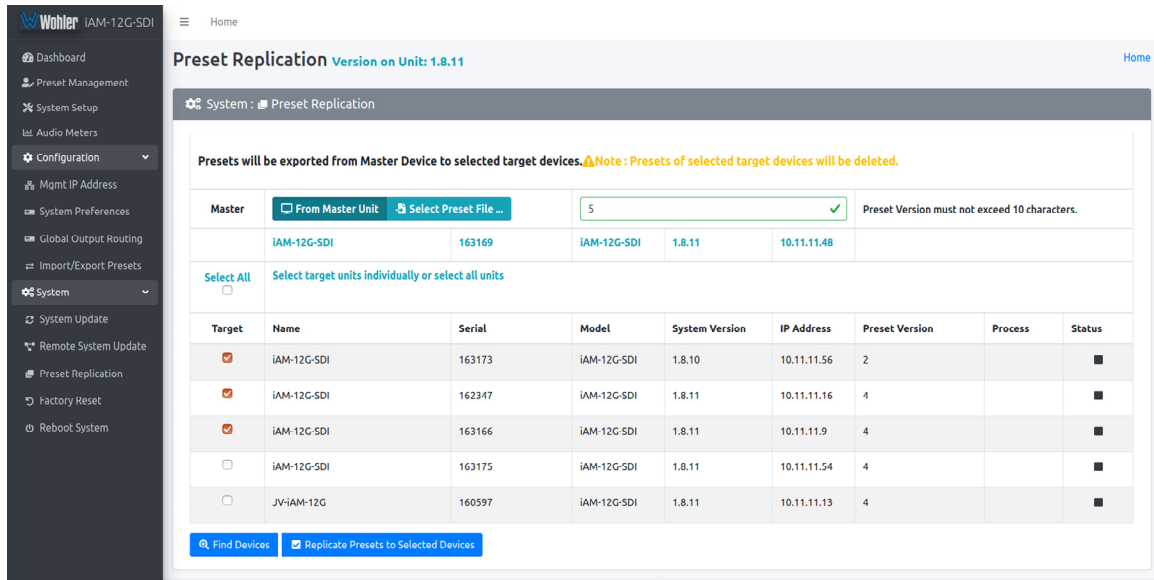

Click either **From Master Unit** or **Select Preset File**. This determines the source of the Presets to be copied. Preset Files would be files that you have previously stored in the computer running the Web GUI.

You may add a descriptive name or version to the Presets being copied. This may aid in remembering what tag or version of the presets are available on the unit. The Preset name or version may be up to 10 characters in length.

Next, select the Target units from the list of units shown by checking or unchecking each of the **Target** boxes at the left. Alternatively, you may click **Select All** to select all of the units. Then select the **Replicate Presets to Selected Devices** button. The progress of the Preset replication for each unit, as the Presets are being copied, will be displayed in the **Process** column. When all of the Presets have been copied to each of the selected units, you may leave this screen.

Remote Monitor

Click on the **Remote Monitor** page to provide a live view of the audio bar graph and Loudness meters for the current preset. There are two tabs, **Audio Meters** and **Dolby Metadata**.

Audio Meters

The following figure shows the **Audio Meters** tab.

Figure 4–21: Remote Monitor Audio Meters

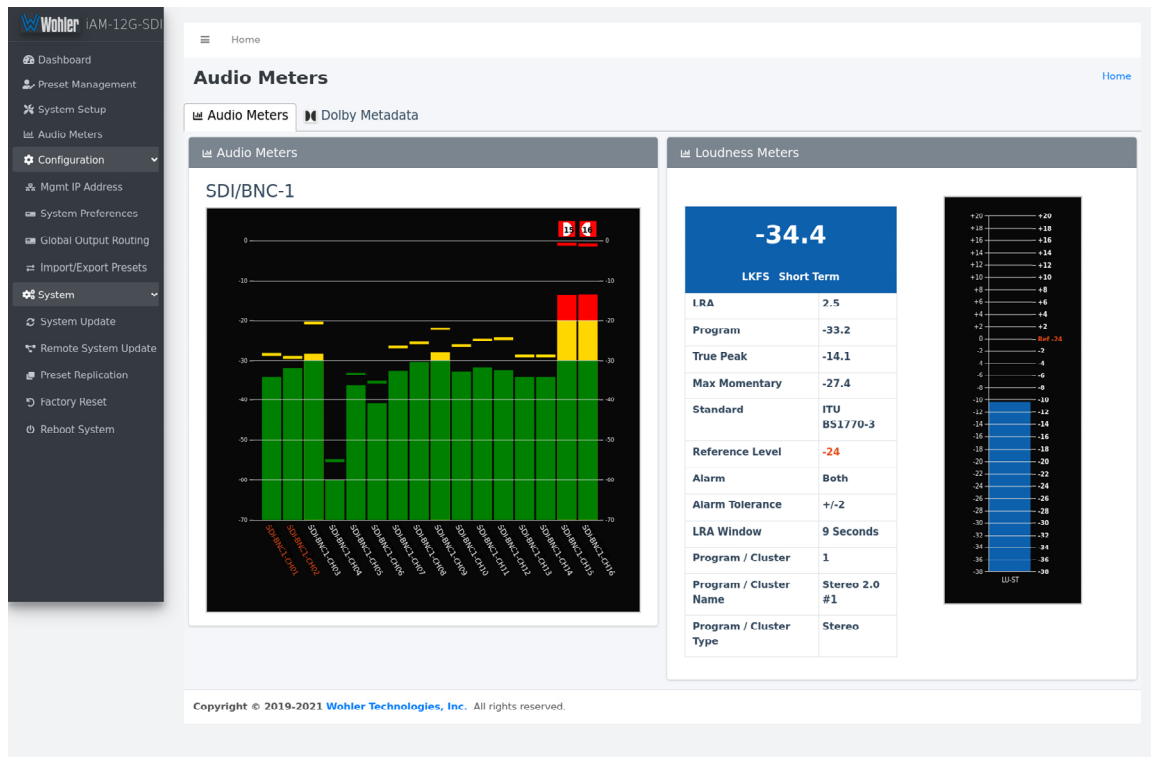

The left side of the screen shows the level meters for the currently selected input source. If a meter pair is indicating a Dolby bitstream, the following symbol appears above the pair:

The right side of the screen shows the Remote Loudness Meter. Both digital and analog meters are displayed. The background color of the digital meter indicates whether or not the displayed level is in an alarm stage. The various alarm stages are denoted by the following colors:

1. No Alarm: **Green**
2. Under Alarm: **Blue**
3. Over Alarm: **Orange**

Included in the view of this meter is a summary of the Loudness settings currently in effect. These parameters can be adjusted in the **Configuration | System Preference | Loudness Configuration** tab of the Web GUI. Refer to Figure 4-27.

Dolby Metadata

The following figures show various Dolby metadata tabs that might be presented.

Figure 4-22 – Remote Monitor ED2: Multiple Presentations

Wohler iAM-12G-SDI

Home

Audio Meters

Audio Meters | **Dolby Metadata**

ED2: Dolby E + Evolution / ED2

Status Information

Substream 1		Substream 2	Loudness	
Frame Type	ED2	ED2	Regulation	ATSC
Type	ED2: Dolby E + Evolution	ED2: Dolby E + Evolution	Meter Mode	ITU-R BS.1770-4
Errors	0	0	Dialnorm	-20
Frame rate	29.97 fps	29.97 fps	True Peak	-19.99
Bit depth	20 bits	20 bits	Momentary Loudness	-19.98
Program configuration	8x1	8x1	Integ. Level Gated Loudness	-19.98
Evo status	Present	Present	Integ. Ungated Loudness	-120.00
Line Position (Lines)	30	30	Integ. Loudness Range	0.00
ED2 Misalignment (Lines)	0	0	Integ. Speech Gated Loudness	-120.00
Signal Type	SDI	SDI	Integ. Speech Percentage	-
Pair	7	8	S.T. 10s Speech Gated Loudness	-120.00
Channel Config.	7.1.2	7.1.2	S.T. 10s Ungated Loudness	-19.98
			S.T. 3s Ungated Loudness	-19.98
			Sample Peak	-20.00

^ Presentation Metadata (Active presentation: P1, 1 of 11)

^ P1 (Active)

Object Metadata

	Bed	Object 1	Object 2	Object 3
Object Type	Bed	Dynamic	Dynamic	Dynamic
Object Class	-	Ordinary	Ordinary	Ordinary
Speaker Config	5.1.2	1.0	1.0	1.0
Object Position x	-	0.00	0.00	0.03
Object Position y	-	0.39	1.00	-0.81
Object Position z	-	0.00	0.00	0.00
Object Source	-	0	0	0
Object Gain	-	0.00	0.00	0.00

^ P2

Object Metadata

	Bed	Object 1	Object 2	Object 3
Object Type	Bed	Dynamic	Dynamic	Dynamic
Object Class	-	Ordinary	Ordinary	Ordinary
Speaker Config	5.1.2	1.0	1.0	1.0
Object Position x	-	0.00	-0.87	0.66
Object Position y	-	1.00	-0.35	-0.35
Object Position z	-	0.00	0.00	0.00
Object Source	-	0	0	0
Object Gain	-	0.00	0.00	0.00

^ P3

^ P4

^ P5

^ P6

^ P7

^ P8

^ P9

^ P10

^ P11

Copyright © 2019-2021 Wohler Technologies, Inc. All rights reserved.

Figure 4-23 – Remote Monitor ED2: Single Presentation

Wohler iAM-12G-SDI

- Dashboard
- Preset Management
- System Setup
- Audio Meters
- Configuration
- Mgmt IP Address
- System Preferences
- Global Output Routing
- Import/Export Presets
- System
- System Update
- Remote System Update
- Preset Replication
- Factory Reset
- Reboot System

Home
Home

Audio Meters

Audio Meters
Dolby Metadata

ED2: Dolby E + Evolution / ED2

Status Information		Loudness	
	Substream 1	Substream 2	
Frame Type	ED2	ED2	Regulation
Type	ED2: Dolby E + Evolution	ED2: Dolby E + Evolution	ATSC
Errors	0	0	Meter Mode
Frame rate	29.97 fps	29.97 fps	ITU-R BS 1770-4
Bit depth	20 bits	20 bits	Dialnorm
Program configuration	8x1	8x1	True Peak
Evo status	Present	Present	Momentary Loudness
Line Position (Lines)	30	30	Integ. Level Gated Loudness
ED2 Misalignment (Lines)	0	0	Integ. Ungated Loudness
Signal Type	SDI	SDI	Integ. Loudness Range
Pair	7	8	Integ. Speech Gated Loudness
Channel Config.	7.1.2	7.1.2	Integ. Speech Percentage
			S.T. 10s Speech Gated Loudness
			S.T. 10s Ungated Loudness
			S.T. 3s Ungated Loudness
			Sample Peak

Presentation Metadata (Active presentation: P1, 1 of 11)

P1 (Active)

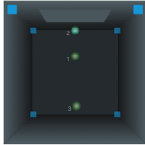

Object Metadata

	Bed	Object 1	Object 2	Object 3
Object Type	Bed	Dynamic	Dynamic	Dynamic
Object Class	-	Ordinary	Ordinary	Ordinary
Speaker Config	6.1.2	1.0	1.0	1.0
Object Position x	-	0.00	0.00	0.03
Object Position y	-	0.39	1.00	-0.81
Object Position z	-	0.00	0.00	0.00
Object Source	-	0	0	0
Object Gain	-	0.00	0.00	0.00

- ∨ P2
- ∨ P3
- ∨ P4
- ∨ P5
- ∨ P6
- ∨ P7
- ∨ P8
- ∨ P9
- ∨ P10
- ∨ P11

Copyright © 2019-2021 Wohler Technologies, Inc. All rights reserved.

Figure 4-24 – Dolby ED2 Misalignment Information

Wohler iAM-12G-SDI

Home

Audio Meters

Audio Meters | Dolby Metadata

ED2: Dolby E + Evolution / ED2

Status Information			Loudness	
	Substream 1	Substream 2		
Frame Type	ED2	ED2	Regulation	ATSC
Type	ED2: Dolby E + Evolution	ED2: Dolby E + Evolution	Meter Mode	ITU-R BS.1770-4
Errors	0	0	Dialnorm	-18
Frame rate	25 fps	25 fps	True Peak	-7.86
Bit depth	20 bits	20 bits	Momentary Loudness	-19.18
Program configuration	8x1	8x1	Integ. Level Gated Loudness	-18.27
Evo status	Present	Present	Integ. Ungated Loudness	-120.00
Line Position (Lines)	2	295	Integ. Loudness Range	4.62
ED2 Misalignment (Lines)	0	293	Integ. Speech Gated Loudness	-120.00
Signal Type	SDI	SDI	Integ. Speech Percentage	-
Pair	1	2	S.T. 10s Speech Gated Loudness	-120.00
Channel Config.	7.1.2	7.1.2	S.T. 10s Ungated Loudness	-19.93
			S.T. 3s Ungated Loudness	-18.19
			Sample Peak	-7.86

Presentation Metadata (Active presentation: 5.1.4 plus 2D, 1 of 1)

5.1.4 plus 2D (Active)

Copyright © 2019-2021 Wohler Technologies, Inc. All rights reserved.

Note: In the figure above, the first substream is the reference and its misalignment value is always 0.

Figure 4-25 – Remote Monitor Dolby E / DE

The screenshot displays the 'Audio Meters' section of the Wohler iAM-12G-SDI remote monitor interface. The interface includes a sidebar menu on the left with options like Dashboard, Preset Management, System Setup, Audio Meters, Configuration, Mgmt IP Address, System Preferences, Global Output Routing, Import/Export Presets, System, System Update, Remote System Update, Preset Replication, Factory Reset, and Reboot System. The main content area is titled 'Audio Meters' and has a sub-tab for 'Dolby Metadata'. It is divided into two main sections: 'Generic Dolby E / DE' and 'Programs'.

Generic Dolby E / DE

Status Information

Status Information		Loudness	
Frame Type	DE	Regulation	ATSC
Type	Generic Dolby E	Meter Mode	ITU-R BS-1770-4
Errors	0	Dialnorm	-20
Frame rate	29.97 fps	True Peak	19.99
Bit depth	20 bits	Momentary Loudness	-20.01
Program configuration	8x1	Integ. Level Gated Loudness	-20.01
Evo status	None	Integ. Ungated Loudness	-120.00
Line Position (Lines)	0	Integ. Loudness Range	0.00
Program count	0	Integ. Speech Gated Loudness	-120.00
Signal type	AES	Integ. Speech Percentage	-
Pair	1	S.T. 10s Speech Gated Loudness	-120.00
Channel Config	5.1.4	S.T. 10s Ungated Loudness	-20.01
Selected Program	1	S.T. 3s Ungated Loudness	-20.01
		Sample Peak	-19.99

Programs

	Program 1	Program 2	Program 3	Program 4	Program 5	Program 6	Program 7	Program 8
Informational								
Dolby Surround	-	-	-	-	-	-	-	-
Production Info	No	No	No	No	No	No	No	No
Room type	-	-	-	-	-	-	-	-
Copyright	No	No	No	No	No	No	No	No
Original Bitstream	Yes	Yes	Yes	Yes	Yes	Yes	Yes	Yes
Dolby Surround EX	-	-	-	-	-	-	-	-
A/D converter	Standard	Standard	Standard	Standard	Standard	Standard	Standard	Standard
RF mode compression profile	Film Standard	Film Standard	Film Standard	Film Standard	Film Standard	Film Standard	Film Standard	Film Standard
Dynamic mode compression profile	Film Standard	Film Standard	Film Standard	Film Standard	Film Standard	Film Standard	Film Standard	Film Standard
Bitstream Info								
Dialnorm (in dB)	-27	-27	-27	-27	-27	-27	-27	-27
Audio coding mode	1/0 (mono) [C]	1/0 (mono) [C]	1/0 (mono) [C]	1/0 (mono) [C]	1/0 (mono) [C]	1/0 (mono) [C]	1/0 (mono) [C]	1/0 (mono) [C]
LFE Channel	OFF	OFF	OFF	OFF	OFF	OFF	OFF	OFF
Bitstream Id	0	0	0	0	0	0	0	0
Downmixing								
Preferred Downmix	-	-	-	-	-	-	-	-
L/R Center Downmix	-	-	-	-	-	-	-	-
L/R Center Downmix	-	-	-	-	-	-	-	-
Lo/Ro Center Downmix	-	-	-	-	-	-	-	-
Lo/Ro Surround Downmix	-	-	-	-	-	-	-	-

Copyright © 2019-2021 Wohler Technologies, Inc. All rights reserved.

Figure 4-26 – Remote Monitor DD+ with ATMOS

The screenshot displays the 'Audio Meters' section of the Wohler iAM-12G-SDI remote monitor. The interface is organized into several expandable sections:

- Audio Meters** (Main Section):
 - ↳ Dolby Digital (Plus) / DD+ with Atmos**
 - Status Information**

Frame Type	DD+
Type	Dolby Digital (Plus)
CRC errors	0
Decode error count	0
Number of streams	1
Atmos Presence	Yes
Signal type	SDI
Pair	1 -
Channel Config	5, 1, 4
 - Loudness**

Regulation	ATSC
Meter Mode	ITU-R BS 1770-4
Dialnorm	-20
True Peak	-19.99
Momentary Loudness	-19.72
Integ. Level Gated Loudness	-19.74
Integ. Ungated Loudness	-120.00
Integ. Loudness Range	0.00
Integ. Speech Gated Loudness	-120.00
Integ. Speech Percentage	-
S.T. 10s Speech Gated Loudness	-120.00
S.T. 10s Ungated Loudness	-19.74
S.T. 3s Ungated Loudness	19.74
Sample Peak	-20.00
 - ↳ Atmos Object Audio Info**

Number of bed objects	10
Number of dynamic objects	0
Center trim (in dB)	0.000000
Surround trim (in dB)	-6.000000
Height trim (in dB)	-3.000000
 - ↳ Streams**
 - Bitstream Info**

Bitstream id	16
Data rate (kbps)	384
Audio coding mode	3/2 (5.1) [L, C, R, Ls, Rs]
LFE Channel	ON
Dialnorm (in dB)	-25
 - Informational**

Bitstream mode	Main complete (CM)
Dolby Surround	-
Production info	No
Room type	Small room, flat monitor
Copyright	Yes
Original Bitstream	Yes
Dolby Surround EX	Not Dolby Surround EX
A/D converter	Standard
NR mode compression profile	Not indicated
Dynamic mode compression profile	Not indicated
 - Downmixing**

Preferred Downmix	LVR
LVR1 Center Downmix	-3.0 dB (0.707)
LVR1 Surround Downmix	-6.0 dB (0.500)
LoRo Center Downmix	-3.0 dB (0.707)
LoRo Surround Downmix	-6.0 dB (0.500)
 - Mixing Metadata**

Scale factor (in dB)	Mute
Ext Program Scale L (in dB)	Not indicated
Ext Program Scale C (in dB)	Not indicated
Ext Program Scale R (in dB)	Not indicated
Ext Program Scale Ls (in dB)	Not indicated
Ext Program Scale Rs (in dB)	Not indicated
Downmix Scale factor (in dB)	Not indicated
Mean angle of rotation index	0.000000
Program Scale Factor	No
Ext Program Scale Aux1 (in dB)	Not indicated
Ext Program Scale Aux2 (in dB)	Not indicated

Copyright © 2019-2021 Wohler Technologies, Inc. All rights reserved.

System Setup

The **System Setup** page expands upon the status information available in the **Dashboard** page, showing the installed option licenses, and provides a means to add additional option licenses. It consists of three tabs, each of which is explained in the sections which follow:

System Information

The **System Setup | System Information** tab provides basic information for this iAM-12G-SDI. It is shown in Figure 4-27.

Figure 4-27: System Setup: System Information

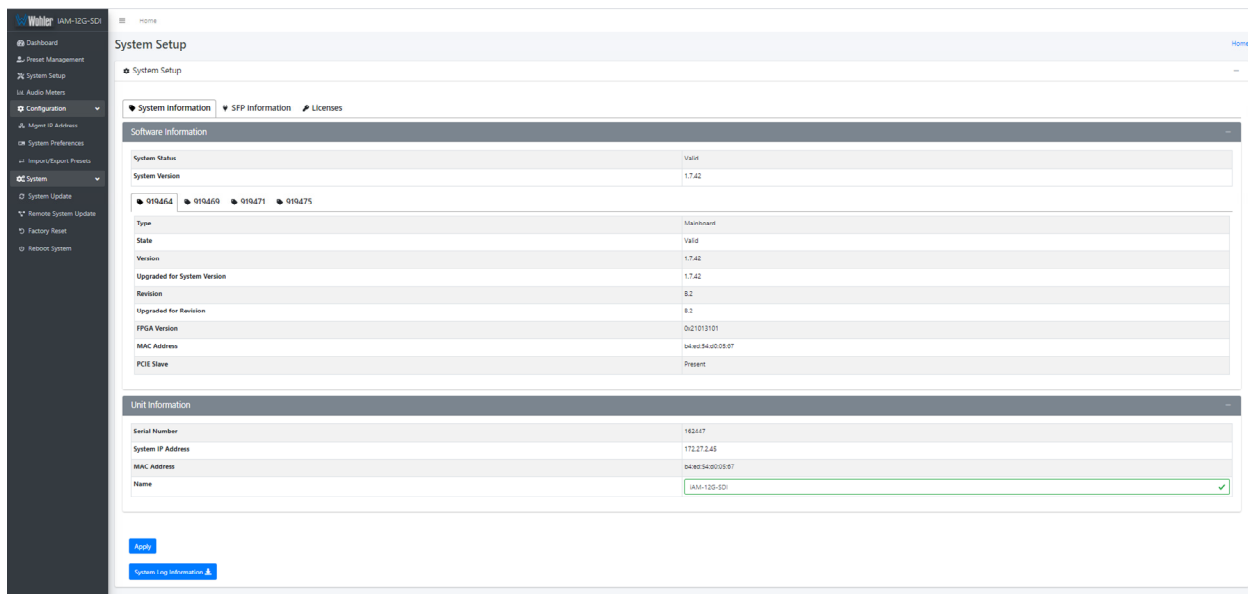

The name of this particular iAM-12G-SDI is shown as the last item in the Unit Information section. It is changeable on this screen by clicking into its field and typing a new name and then click the **Apply** button. The name should be descriptive and perhaps refer to where the iAM-12G-SDI is used in the facility. The name then appears on the browser tab.

The **System Log Information** button at the bottom of the screen may be clicked to download any information logged by the iAM-12G-SDI. This can mainly be used to help solve any issues that may occur, if requested by Wohler Technical Service.

SFP Information

For certain I/O modules, the **System Setup** page will also display the **Hardware/Vitals** status for each module. The examples in Figures 4-28 and 4-29, show the status of the module in SFP Slot 1. The actual information listed in each of these tabs depends upon the module itself, but these figures show some of the types of information and details available.

Figure 4-28: System Setup: SFP Information

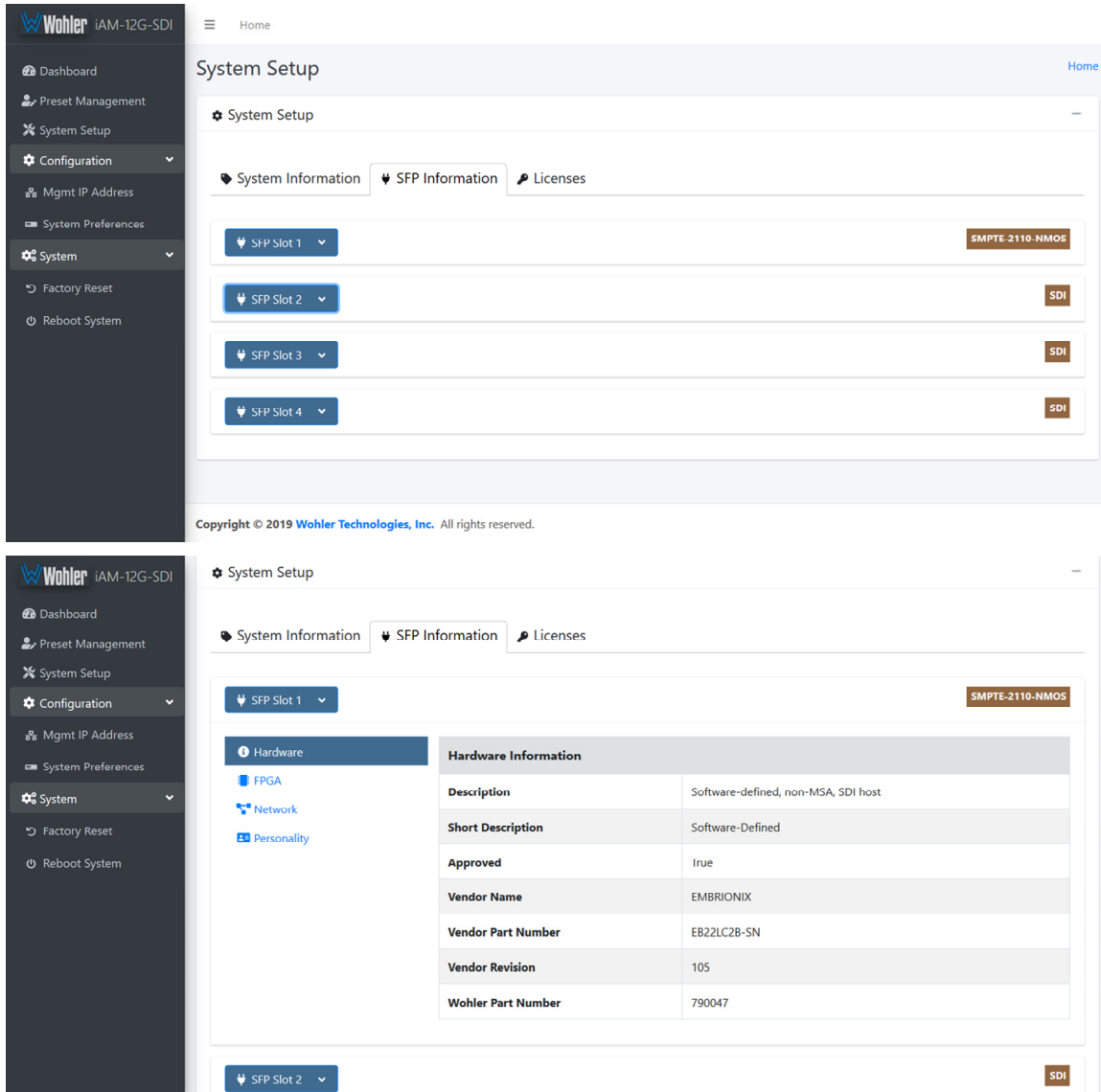

Figure 4–29: System Setup: SFP Information

Wohler iAM-12G-SDI

- Dashboard
- Preset Management
- System Setup
- Configuration
- Mgmt IP Address
- System Preferences
- System
- Factory Reset
- Reboot System

System Setup

System Information | **SFP Information** | Licenses

SFP Slot 1 SMPTE-2110-NMDS

Network Configuration	
Address	10.160.89.176
DHCP	False
DHCP Success	False
Gateway	192.168.39.2
MAC	40:a3:6b:a0:59:b0
Mask	255.0.0.0
Name	emsfp-a0-59-b0

SFP Slot 2 SDI

Hardware Information	
Description	3G/HD/SD/ASI coax video, single Rx, long reach, non-MSA, HD-BNC, active loopback
Short Description	SDI
Approved	True
Vendor Name	EMBRIONIX
Vendor Part Number	EB30HD1R-LN-AL
Vendor Revision	301A
Wohler Part Number	829156

SFP Slot 3 SDI

SFP Slot 4 SDI

Copyright © 2019 Wohler Technologies, Inc. All rights reserved.

Licenses

The **System Setup | Licenses** tab shows the license keys for each of the optional features installed in this iAM-12G-SDI. You may also use this tab to enter new license keys, or enable some license keys. This tab is shown in Figure 4-30.

Figure 4-30: System Setup: Licenses

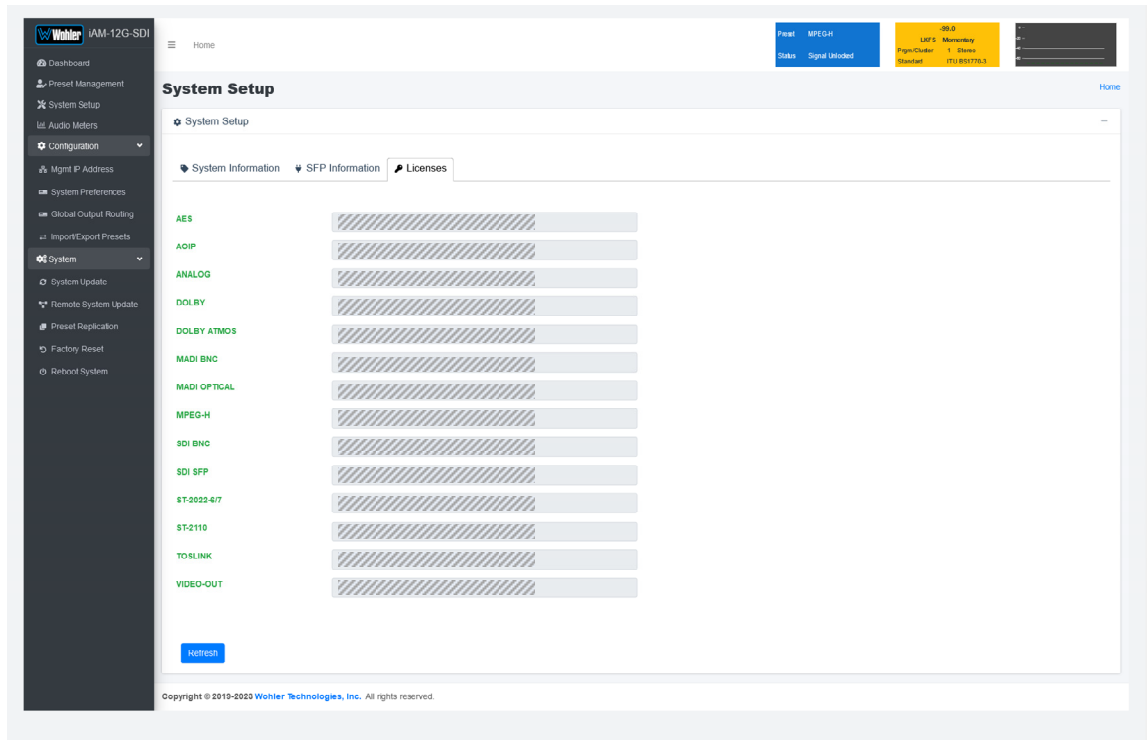

The example above shows an iAM-12G-SDI with license keys for inputs and license keys for SFP modules installed. Licenses without keys will not have the box checked.

To enter the license key provided to you by Wohler Customer Service, use the following steps:

1. Click the checkbox adjacent to the input or module desired.
2. Enter the license key in the box that appears.
3. Repeat Steps 1 and 2 for any other license keys that you want to enter.
4. Click the **Submit** button to save the information. Each new license will be immediately available for use.

Configuration: Management IP Address

Make network **IP Address** changes for **Management (MGMT) Port** of the local iAM-12G-SDI on the screen shown in Figure 4-31.

This screen allows you to configure the management port IP address for the device. Note that after changing the IP address, the web interface should be loaded with the new IP address. If you select DHCP option, than the currently assigned IP address can be determined from the **Front Panel - System Information** screen on the iAM-12G-SDI.

Figure 4–31: Set Management Port IP Addresses

The screenshot displays the 'Set Mgmt IP Address' configuration page. The form includes the following fields and values:

Field	Value
Use DHCP?	<input checked="" type="checkbox"/>
IP Address	192.168.1.62
IP Mask	255.255.255.0
Gateway Address	192.168.1.1
Dns	192.168.1.1

Buttons: Apply, Reset

Copyright © 2019 Wohler Technologies, Inc. All rights reserved.

The procedure for changing the IP Address information is as follows:

1. **Use DHCP?** Check this box if your network has a DHCP server and you want to use dynamic addressing. Otherwise, you must enter static IP address entries in the four fields which follow.
2. **IP Address:** Enter the network address. Leading zeroes are not required.
3. **IP Mask:** This should usually be 255.255.255.0 unless your network can work across multiple subnets.
4. **Gateway Address:** This should usually be the same domain and subnet address numbers as the IP Address, but with the last octet being .1.
5. **DNS:** A default value is shown for reference only. DNS is not normally required for basic static IP network configurations to work. Your IT administrator will specify a value to work with mixed static/dynamic network setups.
6. **Apply:** When you have made all of the necessary entries, press **Apply** to apply the changes.

Configuration: System Preferences

The **System Preferences** selection contains the **Loudness Configuration**, **Phase Indicator Configuration**, **Dolby Settings**, and **Front Panel Configuration** tabs. They allow you to customize screens and measurements. They are explained in the following three sections:

Loudness Configuration

The **Loudness Configuration** tab is shown in Figure 4-32.

Figure 4-32: Loudness Configuration Tab

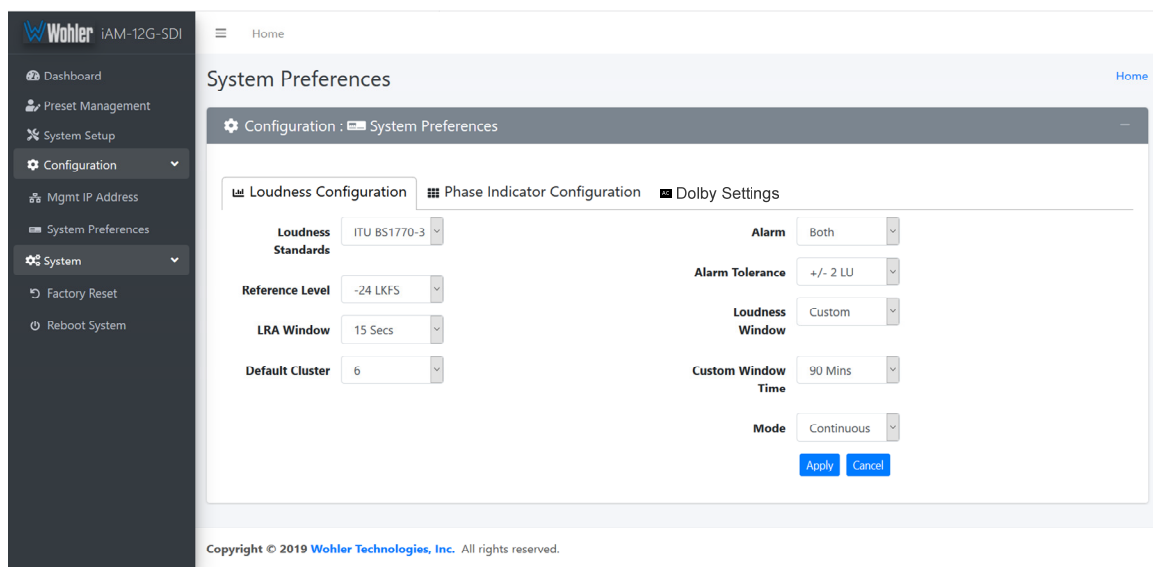

1. **Loudness Standards:** Select from the available loudness standards:
 - a. ITU BS1770-3/4
 - b. EBU R128 (+9)
 - c. EBU R128 (+18)
2. **Reference Level:** For ITU BS1770-3/4, the selection ranges from -30 LKFS to -18 LKFS. For EBU R128 (+9) or EBU R128 (+18), the selection ranges from -30 LUFS to -18 LUFS.
3. **LRA Window:** The **LRA Window** is a moving segment of time over which loudness is calculated. Select from the following times segments:
 - a. 9, 15, 30, or 45 Seconds
 - b. 1, 3, 15, 30, or 45 Minutes
 - c. 1, 2, or 3 Hours
4. **Default Cluster:** Select which Cluster is selected for loudness measurement when the Main Metering Screen appears. Use the pull down list.
5. **Alarm:** Select between the following:

- a. **Over:** The Alarm indication will only appear when Loudness has exceeded the **Reference Level** by the **Tolerance** amount.
 - b. **Under:** The Alarm indication will only appear when the Loudness has been below the **Reference Level** by the **Tolerance** amount.
 - c. **Both:** The Alarm indication will appear when Loudness has exceeded the **Reference Level** by the **Tolerance** amount or has been below the **Reference Level** by the **Tolerance** amount.
 - d. **Off:** The Alarm indication is turned off and will not appear.
6. **Alarm Tolerance:** Select between the following ranges:
- a. +/- 1 LU
 - b. +/- 2 LU
 - c. +/- 3 LU
 - d. +/- 4 LU
 - e. +/- 5 LU
 - f. +/- 6 LU
7. **Loudness Window:** Select between:
- a. **Momentary:** Loudness is measured on a momentary basis which, as defined by the loudness standards, is 400 mS.
 - b. **Short Term:** Loudness is measured on a short term basis which, as defined by the loudness standards, is 3 seconds.
 - c. **Custom:** A selection is available for a **Custom Loudness Window**, a selection of 22 values ranging from one second to two hours. When **Custom** is selected, a pull down box appears to allow a choice to be made.
8. **Custom Window Time:** Select a time from the pull down list.
9. **Mode:** Select between:
- a. **Manual:** This allows measurement of specific, manually timed intervals of time. The **Start** and **Stop** buttons on the **Loudness Meter Screen** are used to control this timing.
 - b. **Continuous:** Loudness calculations will run continuously, except when paused by the **Pause** button on the **Loudness Meter Screen**.

Note: Further and more detailed descriptions of all of the above Loudness terms may be found in the ITU-R BS.1770-3 loudness standard.

When you have made your selections, click the **Apply** button to put them into effect. Alternatively, click the **Cancel** button to undo any setting changes.

Phase Indicator Configuration

The **Phase Indicator Configuration** tab is as shown in Figure 4-33. It allows you to select which channel pairs by default will receive a phase meter on the **Metering Screen**. Generally, it is useful to monitor the relative phase of stereo pairs. However, sometimes each channel of a pair is unrelated to each other. This can be because the channels are used to convey two independent monophonic signals or that one channel may be a Center channel and the other may be a Low Frequency Effects channel. In these instances, the Phase Indicator would almost always indicate an out of phase condition. Because this would be a needless distraction to the operator, switches are provided on the **Phase Indicator Configuration** tab to individually turn phase monitoring for each channel pair on or off. Simply click each switch to the desired on or off position. **Select All** and **Reset All** buttons are also provided. Click **Apply** to incorporate your adjustments or **Cancel** to discard changes you just made.

Note that the default settings made on this tab can be overridden on a Preset by Preset basis on the **Phase Indicator** tab of the **Preset Management** page.

Figure 4–33: Phase Indicator Configuration Tab

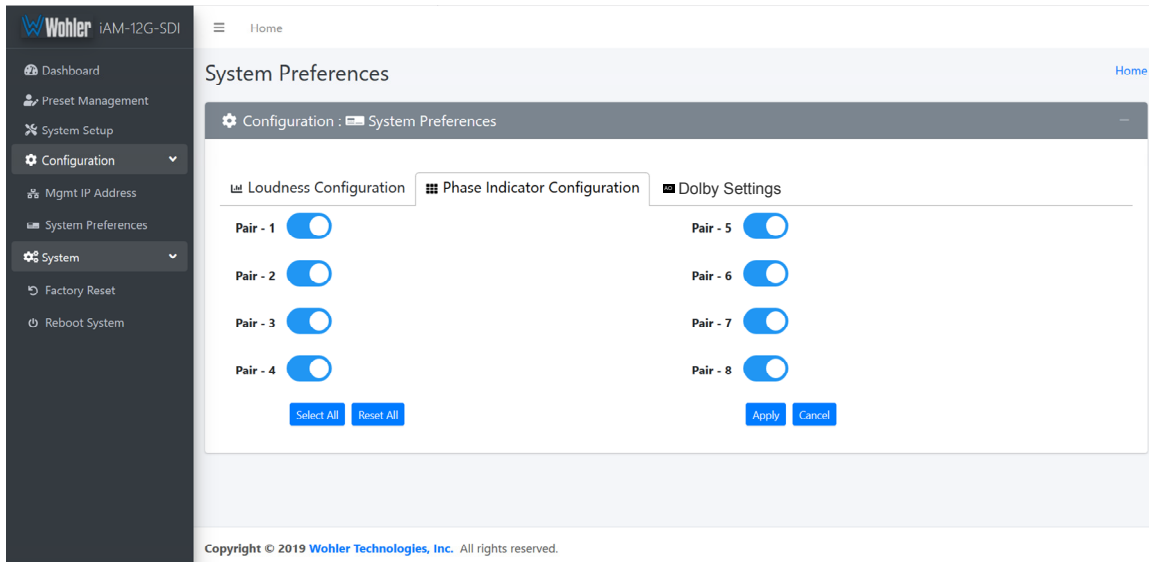

Dolby Settings

The **Dolby Settings** tab is shown in Figure 4-34. There are four sections under the **Dolby Settings** tab: **Decoder Configuration**, **DD+ Configuration**, **ED2 Configuration**, and **Loudness Setup**. The settings in these sections are explained following this figure.

Figure 4-34: Dolby Settings Tab

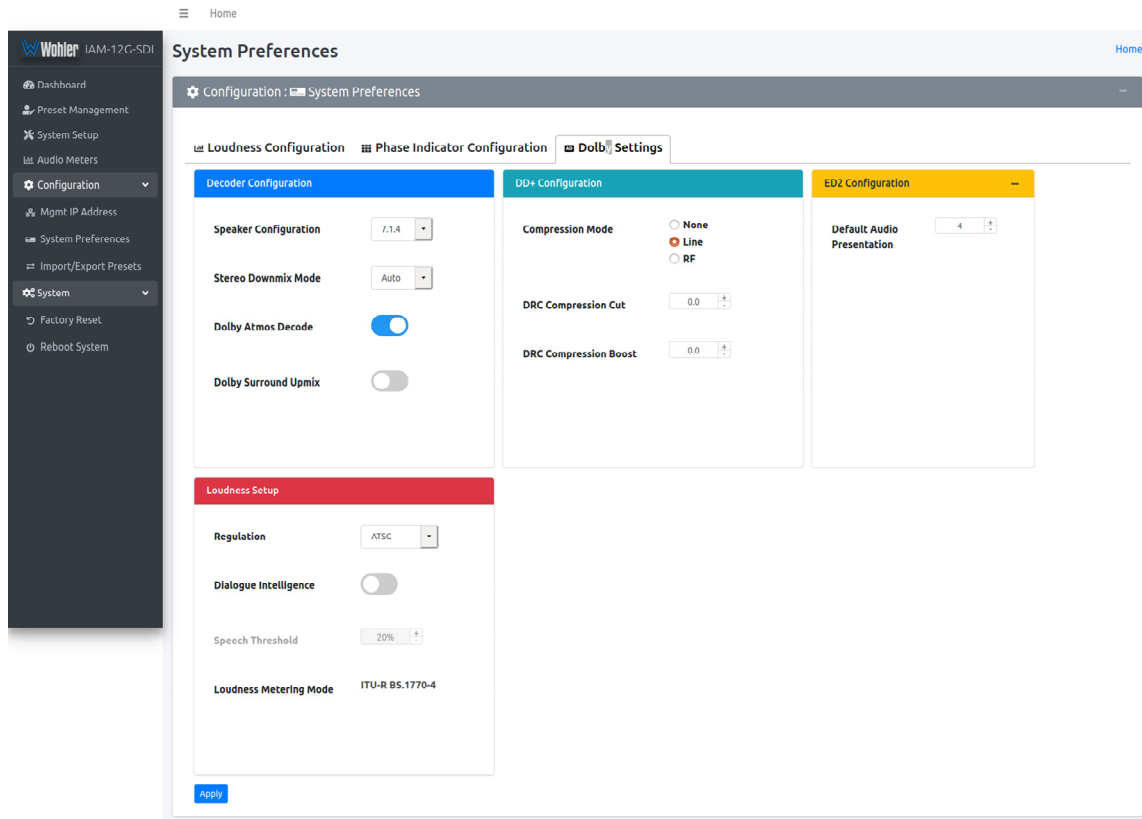

Copyright © 2019-2020 Wohler Technologies, Inc. All rights reserved.

Decoder Configuration

1. **Speaker Configuration:** This setting defines the output speaker configuration in a range from 2.0 to 7.1.4. This setting is reflected in channel descriptions of the audio level meters. Select an option from the pull down list. Speakers that receive no content from the input source are silent.
2. **Stereo Downmix Mode:** This setting provides a choice between Auto, LtRt, or LoRo downmix modes. Select an option from the pull down list.
3. **Dolby Atmos Decode:** This setting applies Dolby Digital Plus bitstreams and to ED2 (ED2: Dolby E + Evolution). (If the optional Dolby Atmos license is not contained in the iAM-12G-SDI, then this option will always be set to the **Off** position. Contact Wohler Sales to obtain this license.) Click the **Dolby Atmos Decode** switch to **On** to enable Dolby Atmos content decoding, or set the switch to **Off** to disable Dolby Atmos content decoding. Dolby Digital Plus with Dolby Atmos content is then decoded as Dolby Digital Plus. When **Dolby Atmos Decode** is set to **Off**, then on the Dolby MetaData screen the **Atmos 3D** or **Show Video** buttons do not display.

4. **Dolby Surround Upmix:** The Dolby Surround Upmix option upmixes channel-based content, but does not apply to audio objects. This setting applies to Dolby Digital Plus bitstreams only. To enable Dolby Surround Upmix, the **Dolby Atmos Decode** option must be turned **On**. Set the **Dolby Surround Upmix** switch to **On** to enable the Dolby Surround Upmix option. Set the switch to **Off** to disable the Dolby Surround Upmix option.

DD+ Configuration

1. **Compression Mode:** Setting a compression mode is not required. If you do not need or want to set the mode, leave the default selection as **Line**. Otherwise, select the **Line** or **RF** mode as appropriate to your decoding requirements.
2. **DRC Compression Cut:** This option is used only when the **Compression Mode** is set to **Line**. 1.0 is equivalent to 100% Dynamic Range Control Compression Cut Rate and each 0.1 is equivalent to 10%. Set the DRC Compression Cut Rate in the range of 0 to 1, in increments of 0.1. Select an option from the pull down list. The default setting is 0.
3. **DRC Compression Boost:** This option is used only when the **Compression Mode** is set to **Line**. 1.0 is equivalent to 100% Dynamic Range Control Compression Boost Rate and each 0.1 is equivalent to 10%. Set the DRC Compression Boost Rate in the range of 0 to 1, in increments of 0.1. Select an option from the pull down list. The default setting is 0.

ED2 Configuration

1. **Audio Presentation:** This option is used only when the Dolby ED2 is present. ED2 supports multiple presentations. This screen allows you to determine which presentation is used as default when in Wohler Zoom mode. Set the Audio Presentation in the range of 1 to 16. If you select a presentation that does not exist in the stream, it will default to Presentation 1.

Loudness Setup

1. **Loudness Standard:** Loudness Standards vary in broadcasting throughout the world. Select the Loudness Standard from the pull down list. The available standards are:
 - a. **ATSC:** For broadcasts originating in North America
 - b. **ARIB:** For broadcasts originating in Japan
 - c. **EBU R128:** For broadcasts originating in Europe
 - d. **Free TV:** For broadcasts originating in Australia
2. **Dialogue Intelligence:** Select **On** to apply Dolby Dialogue Intelligence, if applicable, for the broadcast stream.
3. **Speech Threshold:** Set the Loudness Speech Threshold to any setting between 1 and 100 percent. Select an option from the pull down list. The default setting is 20 percent.
4. **Metering Mode:** This shows the metering mode that was automatically chosen based upon the Loudness standard. Either of the following will be displayed:

- a. ITU-R BS.1770-4
- b. ITU-R BS.1770-4 plus Dialogue Intelligence

Front Panel Configuration Tab

To prevent accidental or unauthorized changing of critical settings in the local product menus, it is possible to restrict access. The Front Panel Configuration Tab entry screen is shown in Figure 4-35. This provides an entryway to the Front Panel Configuration Tab shown in Figure 4-37. To proceed, you must enter the correct Passcode. If no Passcode has been set, the default Passcode is 0-0-0-0.

Figure 4-35: Front Panel Configuration Tab – Passcode Entry

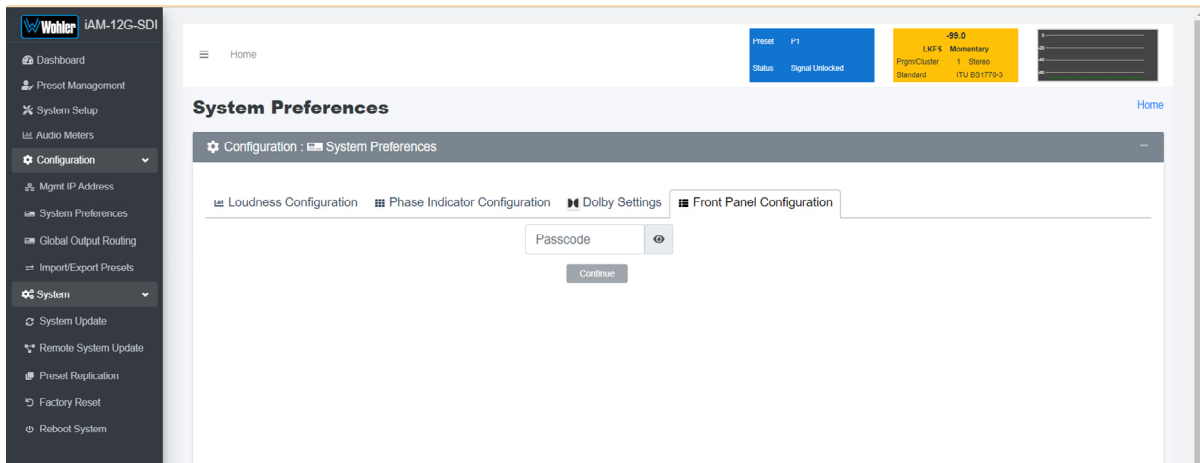

If an incorrect Passcode is entered, the screen shown in Figure 4-36 appears. Click the **Continue** button to try again. If you have forgotten the Passcode, this can be remedied by performing a Factory Reset. Unfortunately, this will also erase all of the menu settings. You may also contact Wohler Technical Service for help.

Figure 4-36: Unrecognized Passcode

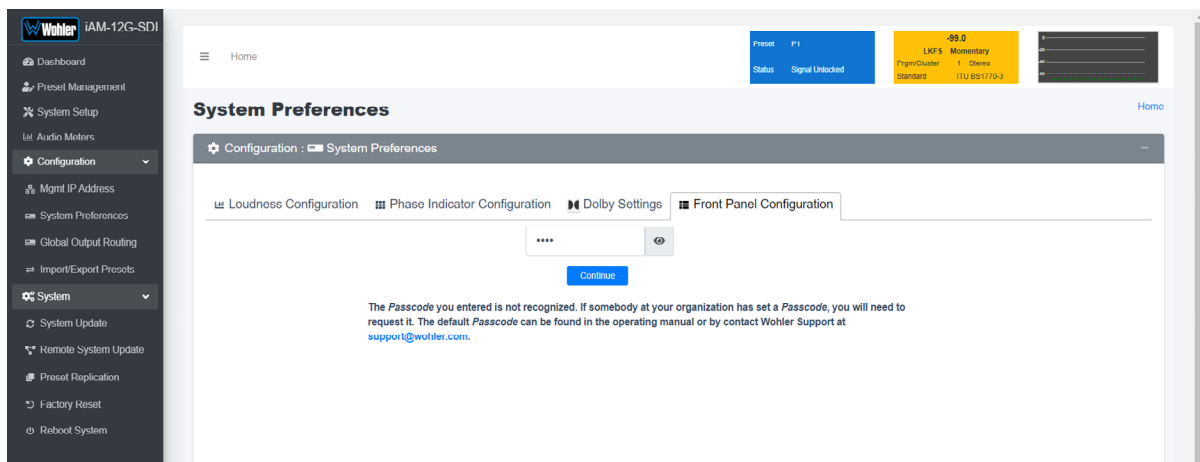

When you have successfully entered the Passcode, the Passcode Settings screen will appear, as shown in Figure 4-37.

Figure 4-37: Front Panel Configuration Tab

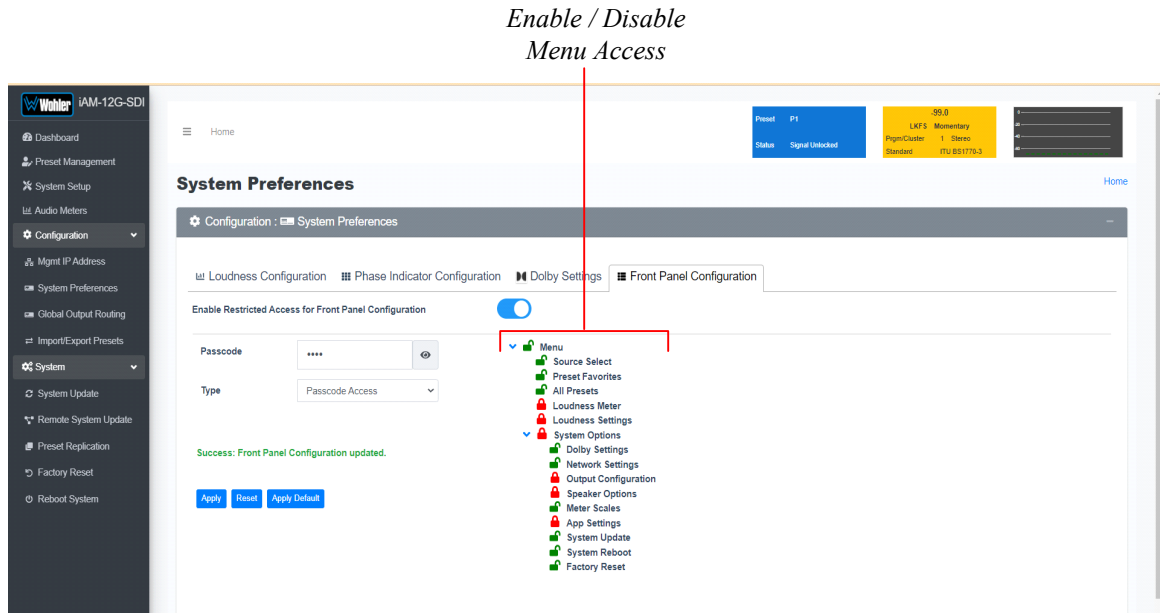

The functions on this screen are as follows:

Enable Restricted Access for Front Panel Configuration: This switch will turn ON or OFF protection or blocking of any local product menus, except for the Passcode Settings menu, which is always Passcode protected.

Passcode: You may enter a new Passcode in this field. The Passcode can be any 4-digit number. Be sure to save the Passcode in a safe place for future reference.

Type: Select the type of disabled button appearance on the local product menus using the **Type** button. The choices are:

Passcode Access: The Passcode protected function buttons include a small orange padlock icon within the buttons. This is shown in the left image of Figure 4-38. These buttons can only be accessed using the correct Passcode.

No Access: If the function buttons are protected by No Access, the buttons are grayed out and non-functional, as shown in the right side of Figure 4-38. These buttons cannot be accessed.

Apply Default: Clicking this button returns the settings in this screen to the factory default values. The Passcode becomes 0-0-0-0.

Reset: Clicking this button undoes any settings you have made on this tab.

Enable / Disable Menu Access: This section provides a nested chart of the local menus that exist in the product. You may set which menus are affected by restrictions. Click any menu shown to change it between affected (red icon) and unaffected (green icon).

Apply: When you have completed the desired settings in this tab, click **Apply** to put them into effect.

Figure 4-38: Examples of Local Menu Protection

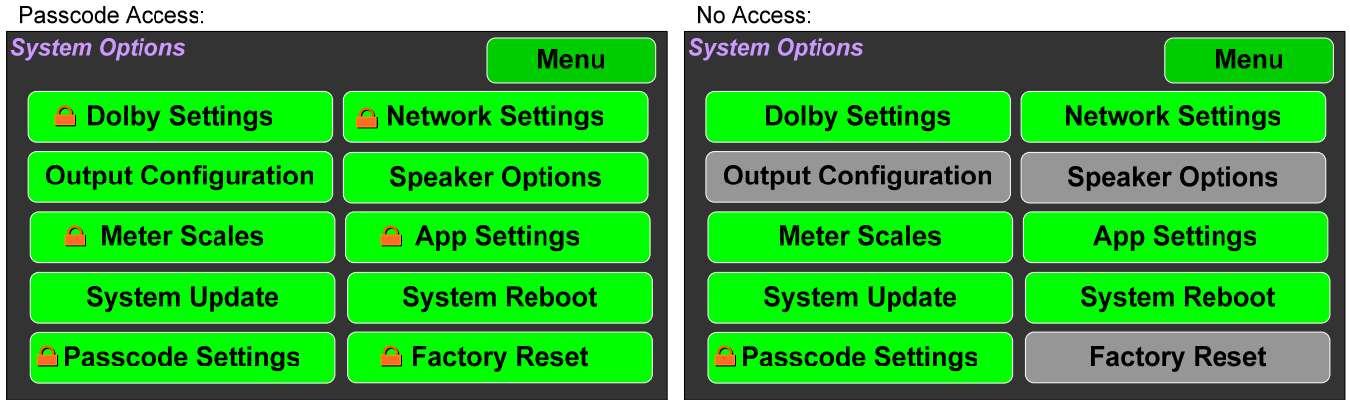

Configuration: Import/Export Presets

Use the **Import / Export Presets** page to manage the Preset database in the iAM-12G-SDI. You may export the Preset database onto the computer hard drive for security backup purposes or as a means to transfer it to another iAM-12G-SDI. Likewise, it can be used to import a Preset database from the computer hard drive into the iAM-12G-SDI. In this way, a Preset configuration may be only devised once and then duplicated into all of the iAM-12G-SDI units in a system, saving significant effort.

The iAM-12G-SDI will create Preset Tags for the each set of Presets. Refer to Figure 4-41. You may also change these Preset Tags, using the Preset Change Field. They allow you to quickly resolve questions about which Presets on various units are the most up to date. They will also allow you to determine whether Presets have been modified. If the Preset Tag displayed contains the suffix "-dirty" then at least one Preset has been changed in some way.

While exporting the file, the Preset Tag is appended to the filename, this allows you to store multiple Preset files with different file name. For example, if the Preset Tag is v1.0.0 then for iAM-12G-SDI the default filename would be "**wohler_presets_iAM-12G-SDI-v1.0.0.pdb**" Do not change the file suffix and prefix (marked in red). However, you may change the Preset Tag to any number or text to suit your requirements.

Figure 4-41: Database Export

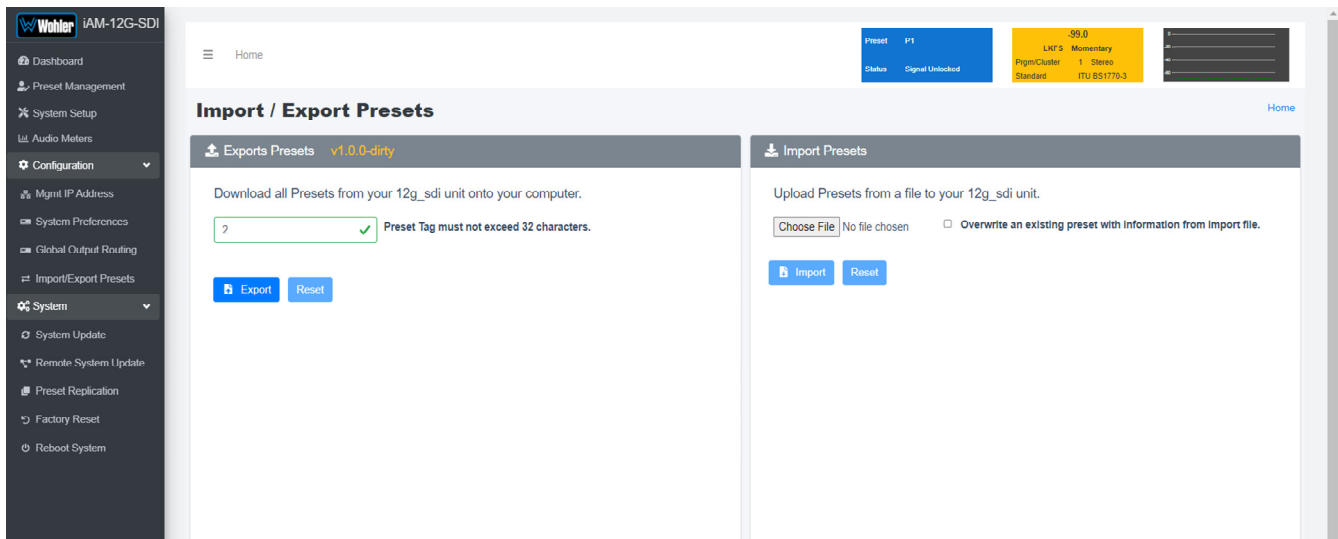

Export Configuration

Use the following steps to save the Preset configuration in the iAM-12G-SDI to the computer hard drive:

1. If you need to, revise the Preset Tag name, observing the advice in the advice in the previous section.
2. Click the **Export** button on the **Import / Export Presets** page, as shown in Figure 4-39.
3. A small **Verify** window will appear:

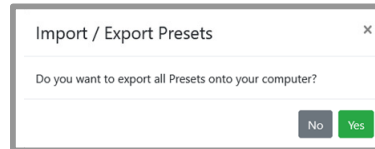

4. Click **Yes** to proceed with writing the Preset data to the hard drive. The copying will proceed. After the Preset data has been written, the screen in Figure 4-40 will appear, explaining what has been exported in an Export Presets Summary. It will also note whether there were any errors in the process. If there were any errors, repeat these steps to try again.

Figure 4-40: Database Export

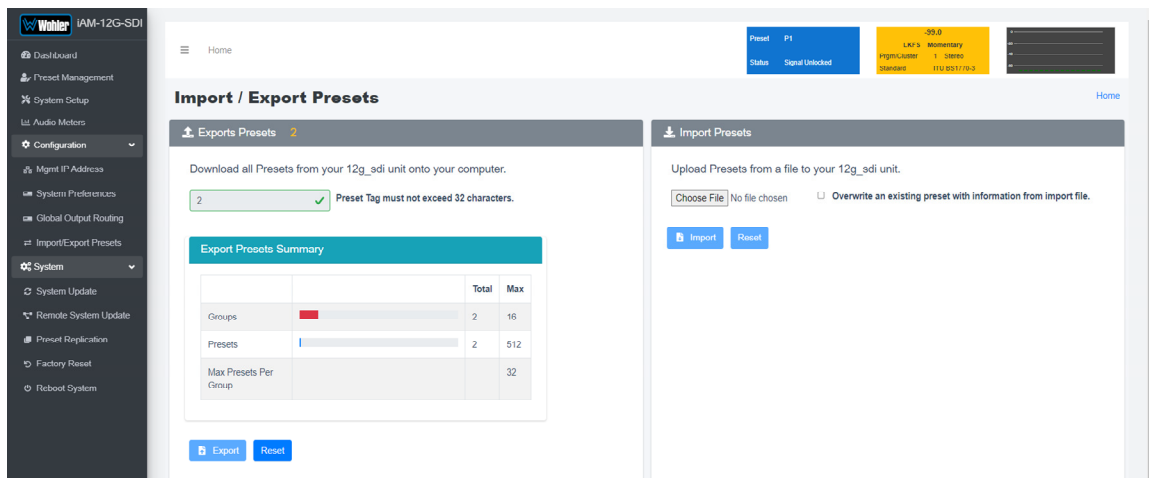

Import Configuration

Use the following steps to copy the Preset configuration into the iAM-12G-SDI:

1. Click the **Choose File** button as shown in Figure 4-40 and select the Preset Tag you would like to import.
2. If you want to allow existing Presets to be overwritten with imported Presets of the same name, check the **Overwrite an existing Preset** box. It is a good idea to do this.
3. Click the **Import** button. The copying will proceed. When complete, the screen in Figure 4-41 will appear, explaining what has been imported in an Import Presets Summary. It will also note whether there were any errors in the process. If there were any errors, repeat these steps to try again.

Figure 4–41: Database Import

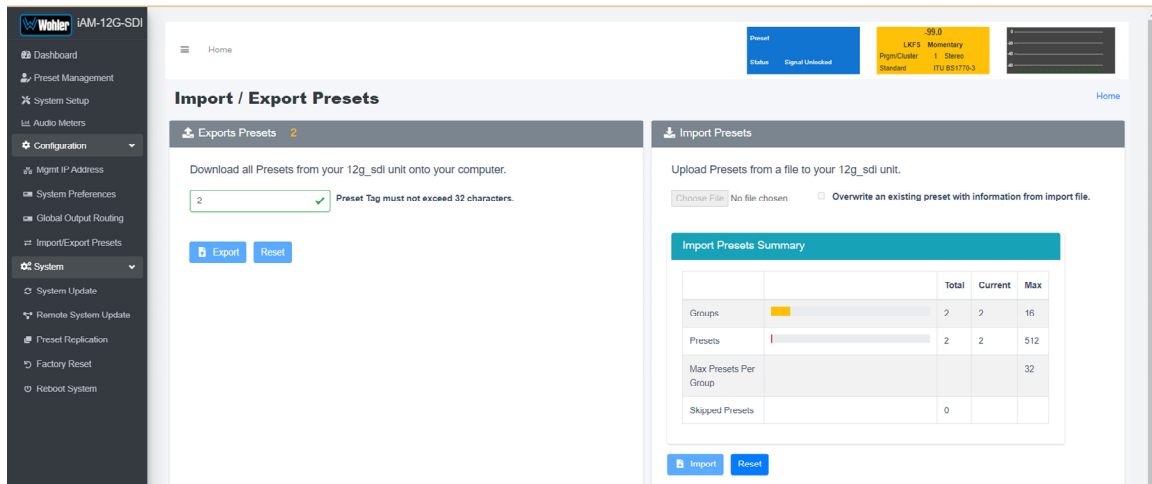

System: Factory Reset

The **Factory Reset** function should be used with caution. It deletes all of the settings you have programmed into the system. It returns the system to the way it was when received new from the factory. After using this function, you will need to reprogram everything from the start or else import a Database or the Presets that you had previously saved. Refer to the **Database Management** section of this chapter.

Figure 4–42: Factory Reset

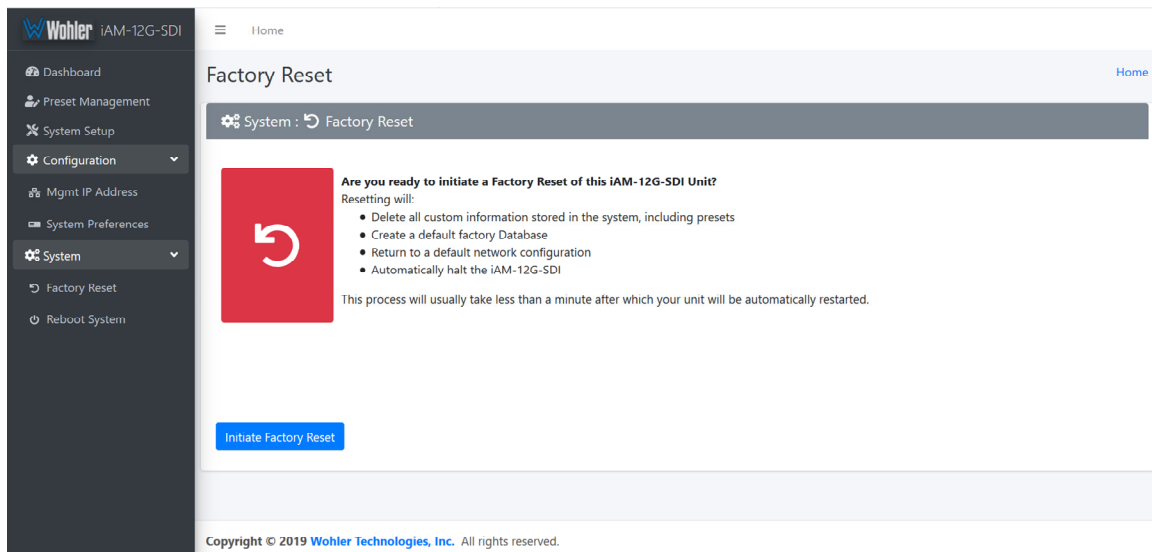

If you have any doubt as to whether you should perform a Factory Reset, do not click the **Reset** button. Contact Wohler Technical Service for advice.

Note: Factory Reset will reset your IP address to the default one (Static IP: 192.168.1.162/Gateway: 192.168.1.1/Netmask: 255.255.255.0) and clear the database of Presets.

System: Reboot System

The **Reboot System** page allows you to reboot an iAM-12G-SDI remotely. The **Reboot System** page is shown in Figure 4-43. This function is normally only used upon request from Wohler Technical Service to troubleshoot or correct an issue.

The **Reboot System** function should be used with a bit of caution. It puts the iAM-12G-SDI out of service for a minute while it is rebooting, and this may unexpectedly interfere with the use of the product by the remote operator.

Figure 4-43: Reboot System

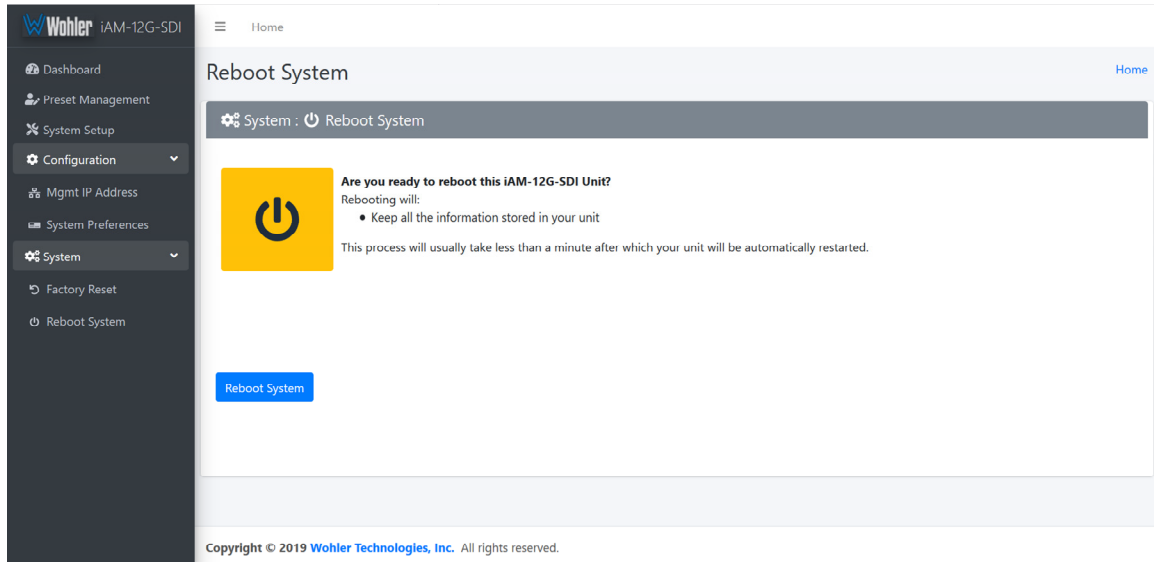

If you have any doubt as to whether you should reboot the remote iAM-12G-SDI, **do not** click the **Reboot System** button. Contact Wohler Technical Service for advice.

APPENDIX A: Software Upgrades

Introduction

This chapter describes how to download a software update file to your computer, transfer it to a USB flash drive and install the updated into an iAM-12G-SDI.

Download the Software

The iAM-12G-SDI software update can be found at <http://www.wohler.com>, under Product Downloads on the Products > iAM-12G-SDI page, in Support > Downloads > Drivers & Software, or contact Wohler Customer Support for more information.

Unzip the downloaded update files to reveal two files. One will have a suffix of **.wx** and the other will have a suffix of **.md5sum**. Both files are needed for the upgrade.

Update Methods

There are several software update methods. Select one of them, depending upon your needs:

1. Local update from the front panel of the iAM-12G-SDI: This straightforward method does not require the use of the Web GUI. A flash drive containing the update is plugged into the front panel USB socket and the update is then accomplished using the self-contained menu system. If this method seems most suitable, then refer to the [Local Update from the Front Panel](#) section of this chapter.

The following three methods can be used only if the iAM-12G-SDI already contains Version 1.7.0 or higher. The version number can be checked by referring to the System tab on the System Information screen.

2. Remote update using the Web GUI with a flash drive connected to the iAM-12G-SDI: It may be more convenient to update the product using a flash drive plugged into its front panel USB socket, but controlled remotely via the Web GUI. To update the product this way, refer to the [Updating via the Web GUI](#) section of this chapter.
3. Remote update without a flash drive: This method allows you to update a networked iAM-12G-SDI remotely without plugging a flash drive into its front panel USB socket. To update the product this way, refer to the [Updating an iAM-12G-SDI Remotely](#) section of this chapter.
4. Update multiple units remotely at once: This method allows you to update multiple networked iAM-12G-SDI units at once, without plugging flash drives into their front panel USB sockets. To update products this way, refer to the [Updating Multiple iAM-12G-SDI Units Remotely](#) section of this chapter.

Local Update from the Front Panel

Use the following steps to update the iAM-12G-SDI software:

1. Copy the unzipped Wohler Update Package file(s) from your computer to the root directory (not inside of a folder) of a USB flash drive. It must be FAT32 file type, and does not need to be empty. Refer to the [Download the Software](#) section of this chapter for the specifics of download and file transfer to the USB flash drive.
2. Insert the USB flash drive with iAM-12G-SDI update package(s) into the front panel USB jack.
3. From the **Menu** screen, touch **System Options**. The screen shown in Figure A-1 will appear.

Figure A-1 - System Options Screen

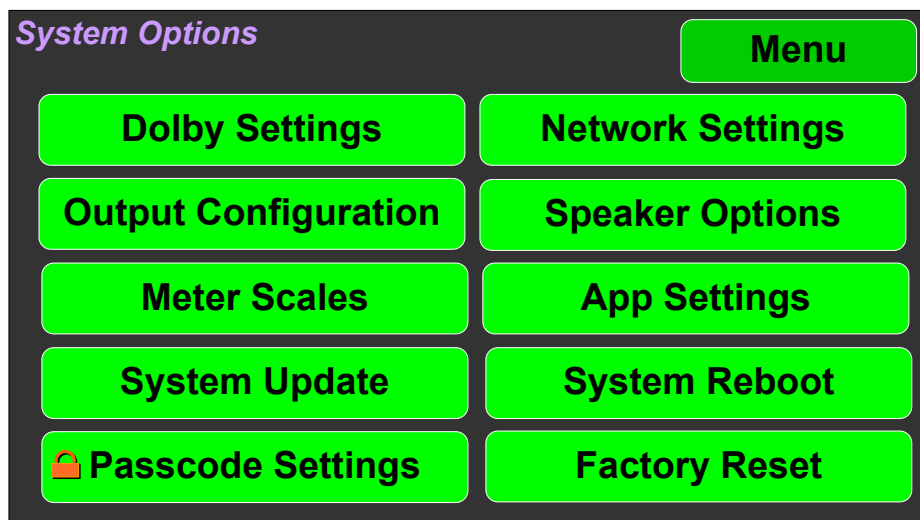

4. In the **System Options** menu, touch **System Update**. The **Software Upgrade** screen will appear, as shown in Figure A-2.

Figure A-2 - Software Upgrade Screen

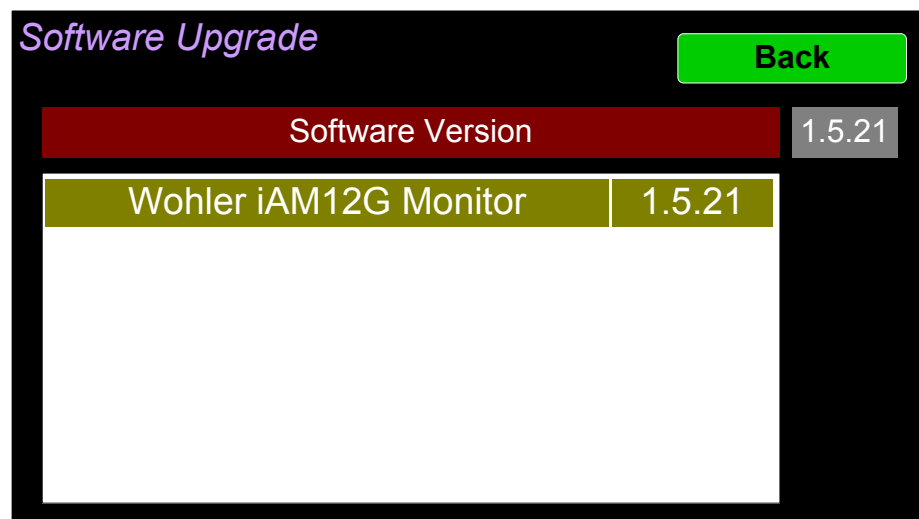

- The new software version that is in the flash drive will be shown in the **Software Version** screen. To cancel the upgrade at this point for any reason, touch **Back**. To proceed, touch the software version entry in the **Software Version** screen. A screen will appear, as shown in Figure A-3.

Figure A-3 - Upgrade Verify

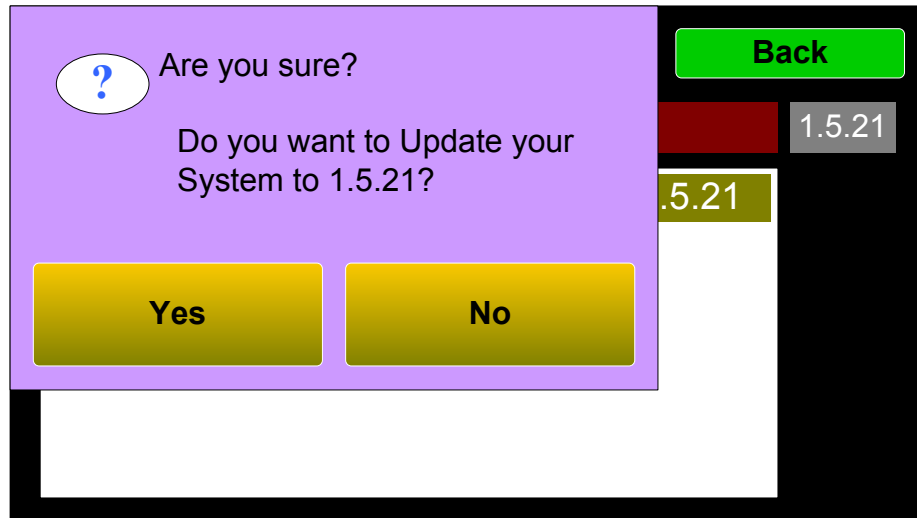

- To proceed, touch **Yes**. To back out, touch **No**. After you touch **Yes**, the screens will change, as shown in Figure A-4. The message on this screen will change as the upgrade progresses. The left screen will display, "Software Upgrade in Progress" until the upgrade is complete.

Figure A-4 - Upgrading System

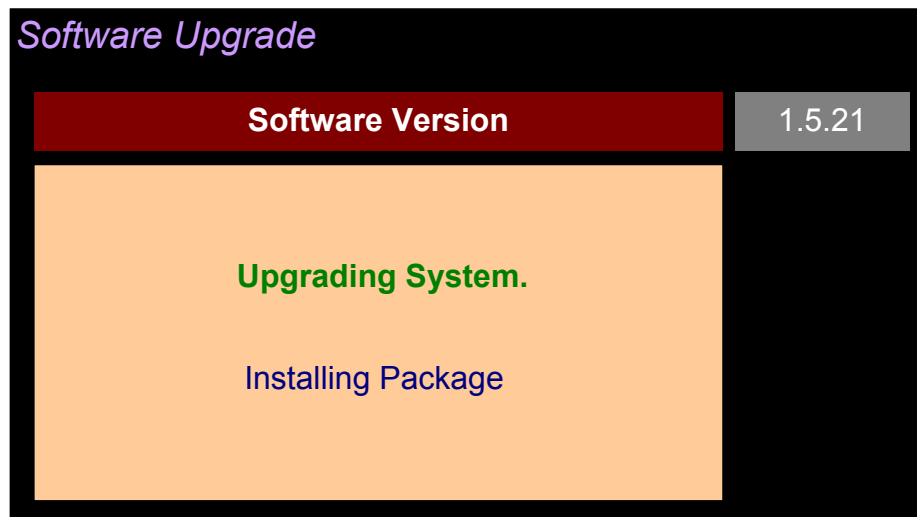

Note: If you attempt a software upgrade fairly soon after you have powered up the iAM-12G-SDI, and it contains a Dolby Decoder module, it can happen that the Dolby Decoder module hasn't yet had enough time to boot up. In this case, the screen shown in Figure A-5 will appear. After the Dolby Decoder module has completely booted up, the screen will be replaced by the screen in Figure A-2 and you may proceed with the software update. Return to Step 5 of this procedure.

Figure A-5 - Upgrading System

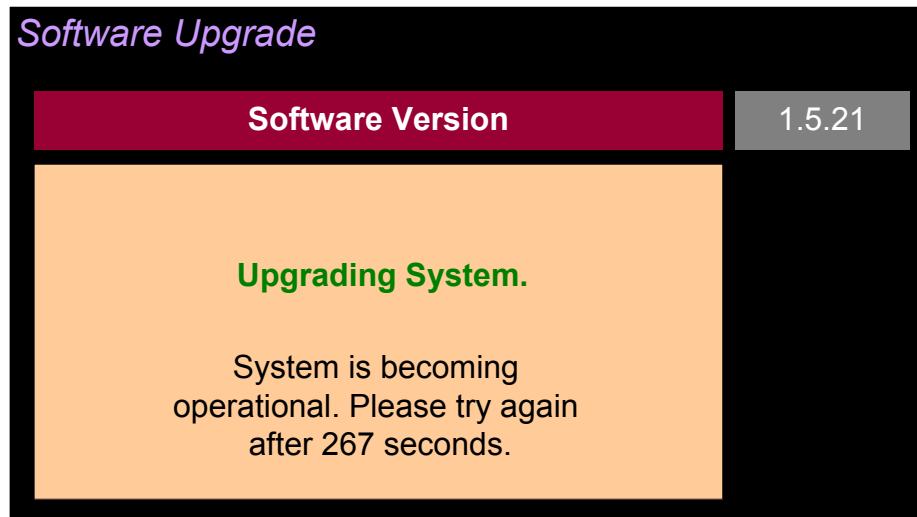

7. After the software update starts, the text on the left screen will change periodically to indicate the progression of the upgrade. The upgrade will take 5 minutes or more, after which the iAM-12G-SDI will restart. After the system has completed its restart cycle and is once again operational, you may then remove the flash drive.

Important:

Do not interrupt or remove power to the iAM-12G-SDI, or remove the USB drive during the installation process. Doing so could crash the iAM-12G-SDI software.

Updating via the Web GUI using a Flash Drive

Use the following steps to update the iAM-12G-SDI software:

1. Copy the unzipped Wohler Update Package file(s) from your computer to the root directory (not inside of a folder) of a USB flash drive. It must be FAT32 file type, and does not need to be empty. Refer to the [Download the Software](#) section of this chapter for the specifics of download and file transfer to the USB flash drive.
2. Connect to the iAM-12G-SDI with the Wohler Web GUI. Navigate to the **System | System Update** menu, as shown in Figure A-6. If the iAM-12G-SDI has recently been powered and it contains the Dolby Decoder option, then a message may appear asking you to wait for a number of seconds so that the decoder will be operational.

Figure A-6 – System Update Menu

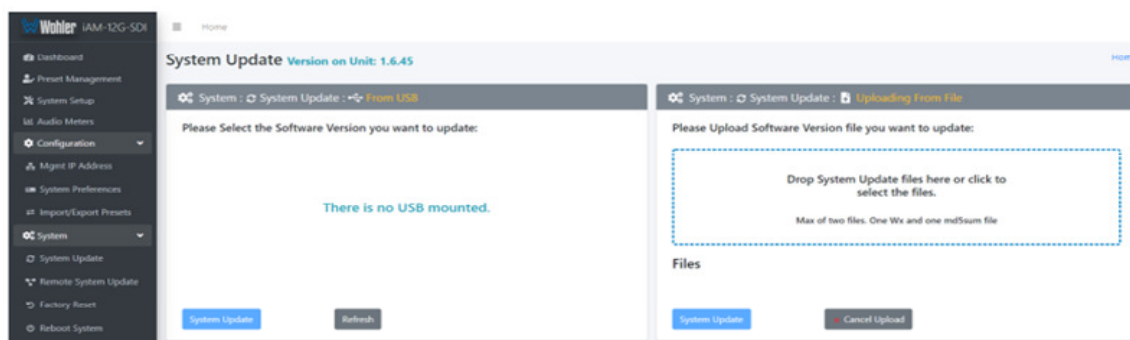

3. Click on the **Refresh** button.
4. Available software update(s) are shown as in Figure A-7. Click the one you want, followed by clicking the **System Update** button.

Figure A-7 – Available Software Updates

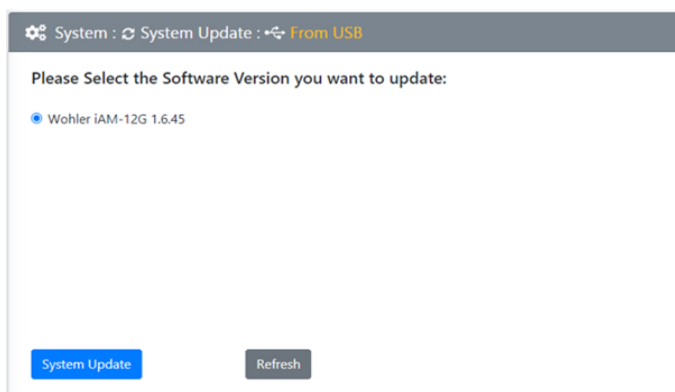

5. After clicking the System Update button, a verification screen displays as shown in Figure A-8. If you agree that the correct update version has been selected, click the **Yes** button.

Figure A-8 – System Update Verification

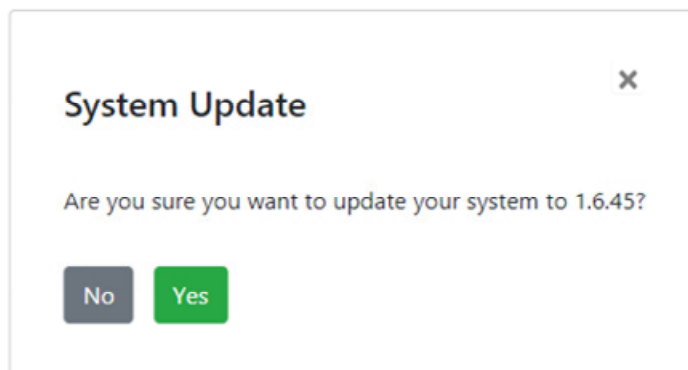

6. Next, the update begins, showing the screen in Figure A-9. The circle in the

center of the screen, along with status messages below it, will indicate the progress of the update.

Figure A-9 – Software Upgrade in Progress

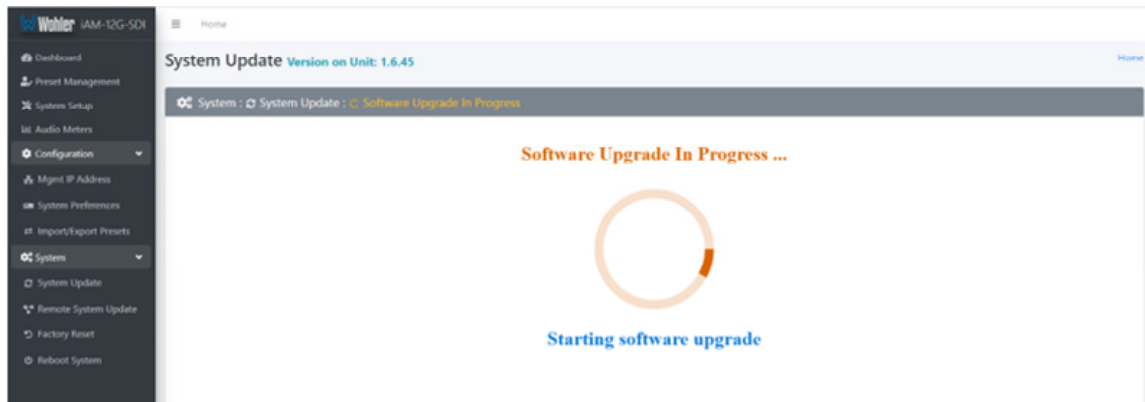

7. At this point, wait for the update to complete. It may take several minutes, but **it is critical not to disturb the iAM-12G-SDI or the Web GUI** until the update process is complete. When it is complete, the iAM-12G-SDI will restart.

Updating an iAM-12G-SDI Remotely

Use the following steps to update the iAM-12G-SDI software:

1. The Software Update files you downloaded earlier must be in the same computer that is running the Web GUI. Connect to the iAM-12G-SDI with the Wohler Web GUI. Navigate to the **System | System Update** menu. Click within the large blue dotted line rectangle at the right of the screen. A file selection window will open, as shown in Figure A-10.

Figure A-10 – System Update Menu

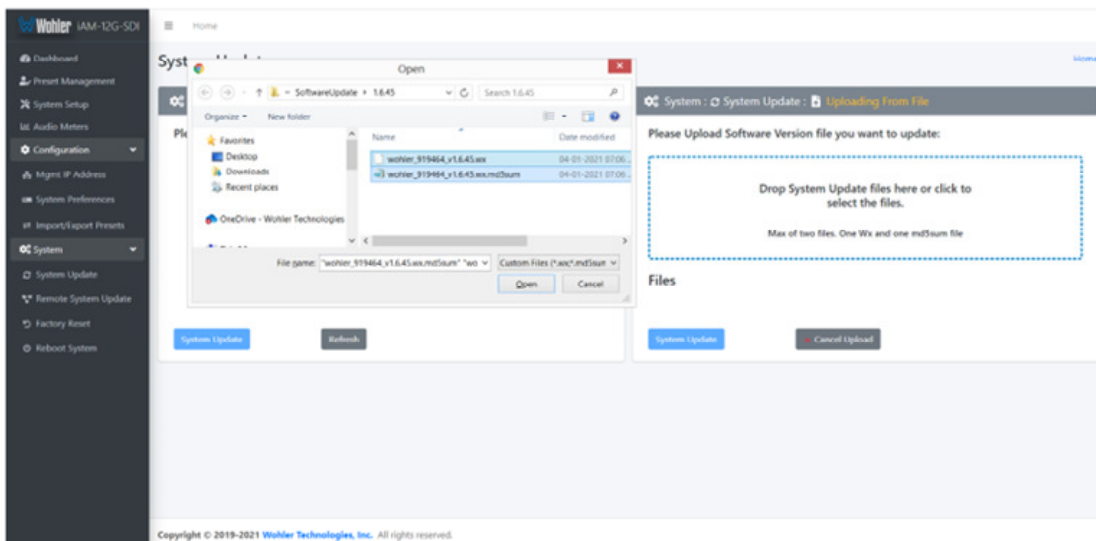

2. Click the two update files. One will have a suffix of **.wx** and the other will have a suffix of **.md5sum**. If you make a mistake and click the wrong file(s), click the **Cancel Upload** button and try again. When the files have uploaded, the **System Update** button will be enabled. Click it. If there is a problem with the files as this point one of the screens shown in Figures A-11 or A-12 will appear. In that case follow the directions on the screen to retry. If there are no problems, the update will proceed and the screen shown in Figure A-9 will appear.

Figure A-11 – Invalid System File Version

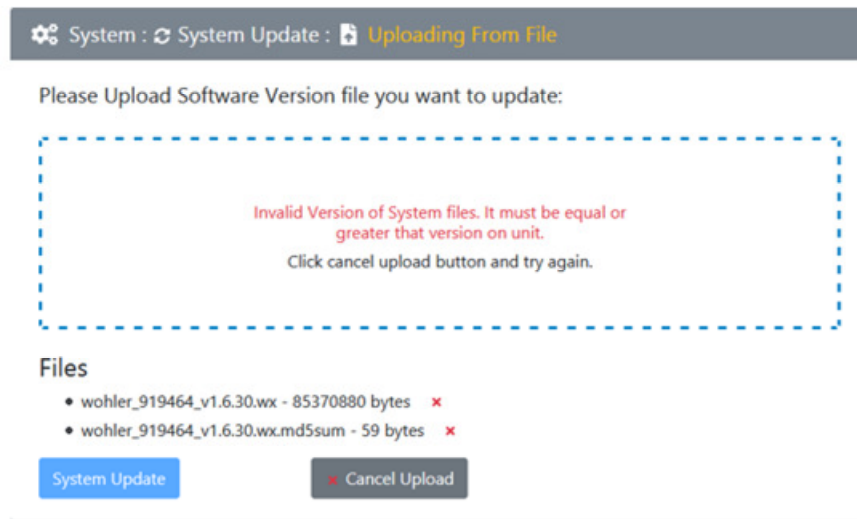
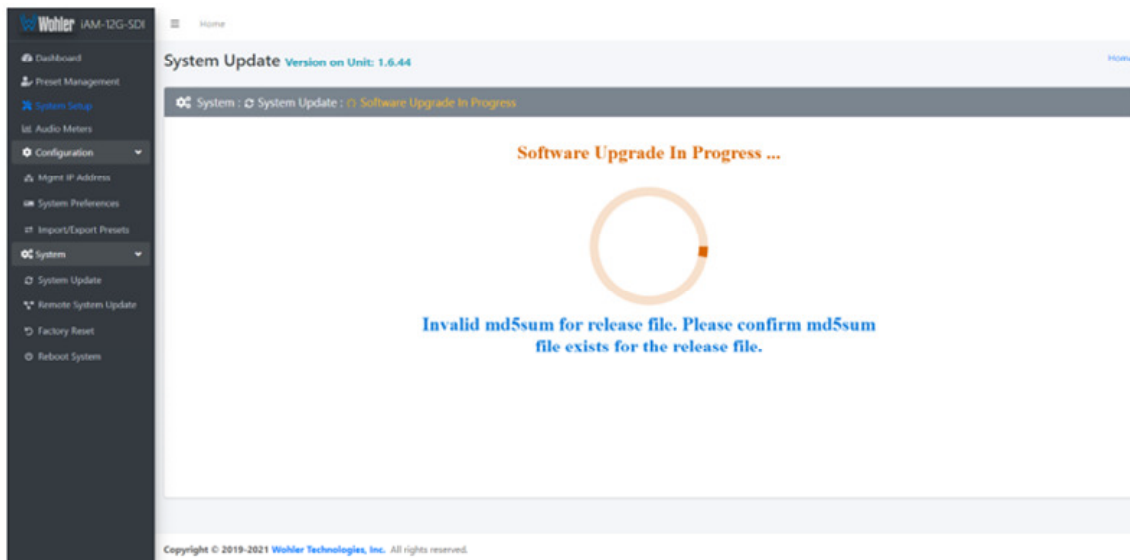

Figure A-12 – Invalid Checksum



3. At this point, wait for the update to complete. It may take several minutes, but **it is critical not to disturb the iAM-12G-SDI or the Web GUI** until the update process is complete. When it is complete, the iAM-12G-SDI will restart.

Updating Multiple Units Remotely

Use the following steps to update one or more iAM-12G-SDI units remotely by transferring the software from a previously updated iAM-12G-SDI:

1. If any of the iAM-12G-SDI units that you intend to update remotely may be in use, contact the people using them and let them know what you will be doing. The iAM-12G-SDI units being updated will be temporarily out of service.
2. Use the Wohler Web GUI to connect to an iAM-12G-SDI already containing the latest update. This will be referred to as the **Master Unit**. Navigate to the **System | System Update | Remote System Update** menu. The screen shown in Figure A-13 will appear and the Web GUI will scan the network for any active iAM-12G-SDI units.

Figure A-13 – Scanning for iAM-12G-SDI Units

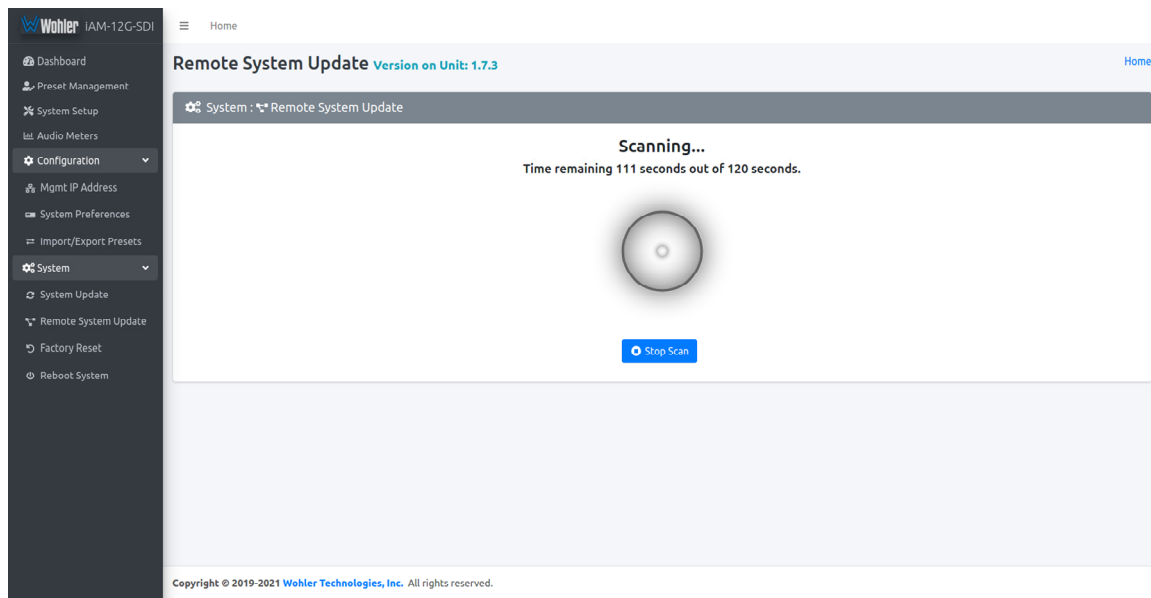

Note: The scanning process will take 2 minutes. Progress is shown on the screen. If for some reason you would like to stop the scan prematurely, click the **Stop Scan** button.

Important: **Do not** run the scanning or updating process from **more than one Master Unit** at a time, to avoid problems. Although you may be updating multiple units at the same time, never attempt this process from more than one **Master Unit**.

3. When the scanning is complete, a list of found iAM-12G-SDI units will be shown as in Figure A-14. Click either **Select All** or click only the **Target** units that you want to update.

Figure A-14 – List of Found iAM-12G-SDI Units

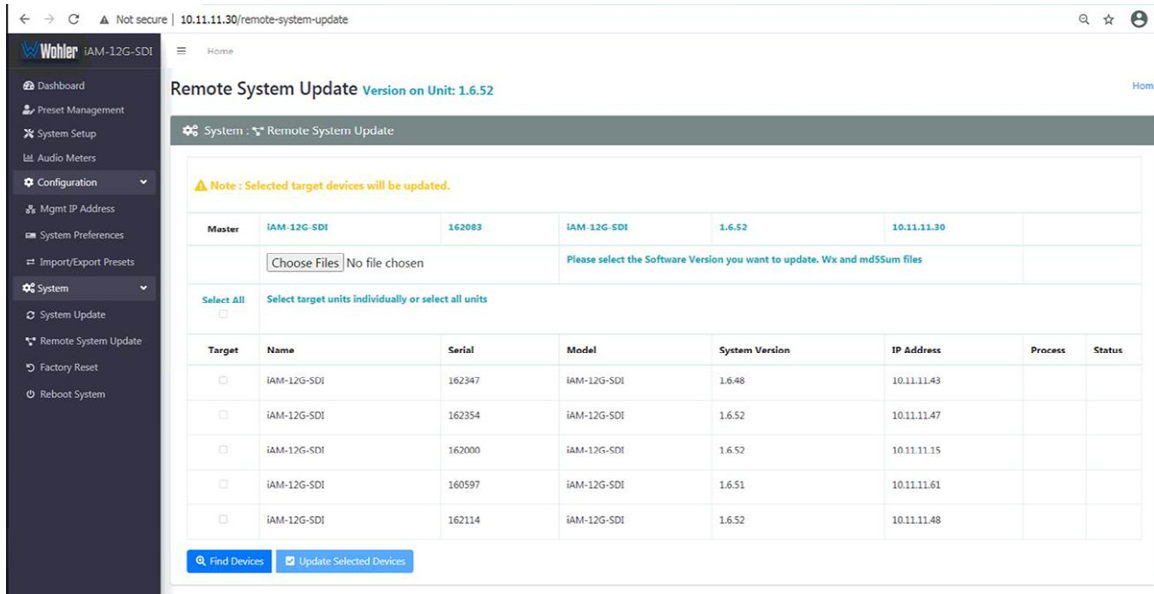

4. Then click **Update Selected Devices**. The window shown in Figure A-15 will appear.

Figure A-15 – Apply System Package

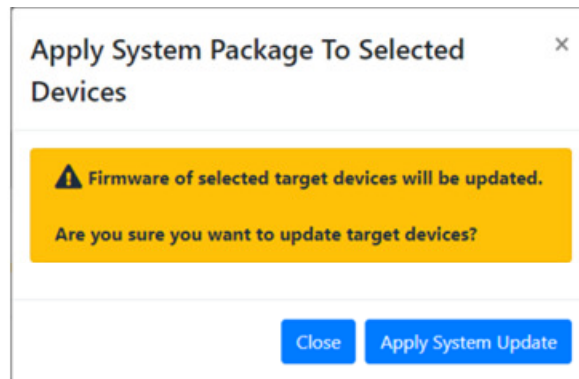

5. Click **Apply System Update**. The screen shown in Figure A-16 will appear. This screen contains a table showing the update progress of each of the iAM-12G-SDI units being updated.

APPENDIX B: Dante Network Setup

Introduction

Installing the iAM-12G-SDI into an existing and functioning Dante network is virtually plug and play. The iAM rear panel AoIP jack supports 1Gb/s and 100Mb/s Ethernet devices in Dante Audio over IP network configurations.

iAM-12G-SDI channel source selections are made by choosing **Input Type 'AoIP'** in the [Configuration-Configure Presets](#) page regardless of which AoIP option is installed.

The iAM-12G-SDI is set up at the Wohler factory to be used as a slave rather than a master within the Dante network. Other devices or software, such as a **Dante Controller**, are expected to be responsible for most device configurations and all audio routing.

Please refer to the **Dante Controller User Guide** or other control device documentation for specific network and device setup information. The next section provides a guide to configuring the card and AOiP port.

What is in the iAM-12G-SDI for Dante

The Dante AOIP option consists of an Audinate Brooklyn II card directly connected to the AOIP port. This port is dedicated to the card and should not be confused with the Wohler unit Management port. These two ports must be on two different subnets, one for the AOIP network and the other for access to the Wohler Web GUI for management of the Wohler unit itself. Either one can be configured to have static or DHCP addresses. The Wohler Web GUI indicates the presence of the Dante card and the AOIP license but does not provide access to the various configuration parameters internal to the card. The speed of the AOIP port is 1G default or 100Mbps.

The Audinate® Brooklyn II card has a simple process to set its initial IP address. The initial factory setting for the card's AOIP port is DHCP. When connected to a DHCP based Dante network and the unit powered on, the Dante card sets the DHCP server provided address as its default address.

Therefore, if the Dante network has a DHCP server, the unit can be inserted into the network and can be configured further using the Audinate application, Dante Controller, running on a host on the same DHCP based subnet.

If the Dante network is static based or if DHCP fails, the card sets a static Link Local arbitrary address in the format 169.254.x.y, where x and y are each in the range 0 to 255. The mask is set to 255.255.0.0 to provide a ~65000 entry address space.

The Dante Controller host must also have a Link Local address to communicate with the card over the unit's AOIP port. Connect the AOIP port directly to a host (e.g. laptop) running the Dante Controller, where the host address is preconfigured to an arbitrary Link Local address (169.254.x.y, mask 255.255.0.0). The connection can be direct cable or through a switch. The Dante Controller **Device Info** tab shows the card's default static address, speed, etc. By double clicking its entry line,

additional settable parameters on the card can be reconfigured to be compatible with the Dante network addressing and other parameters as necessary. When the unit is rebooted on the Dante network, the card will be seen by the Dante Controller used to manage the overall network.

If the Dante Controller **Device Info** tab detects the card but does not allow modification and full presentation of card internals, the **Card ID** will be shown in red, e.g. Wohler-xxxxxx where xxxxxx is the last 6 hex digits of the card MAC address as shown in B-1. This usually indicates that the IP address of the card is not in the same subnet as the Dante Controller host. By double clicking the ID, a **Device View** screen will appear as also shown in Figure B-1 with further details about the two incompatible addresses. Change the address of the host or move the unit to another host with an address compatible with the Dante card.

Figure B-1 – Dante Controller Device Info Tab

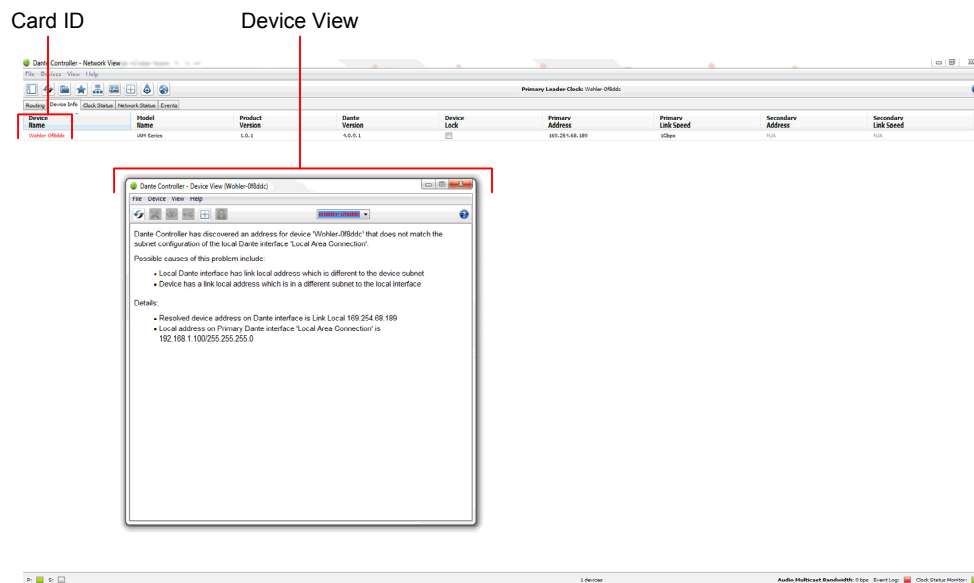

Up to sixteen of the 64 AoIP receive channels can be monitored at once in the iAM-12G-SDI. The sixteen iAM-12G-SDI input channels selected by presets are transmitted to the Dante network.

The iAM-12G-SDI Dante™ AoIP is configured by the iAM-12G-SDI to receive up to 64 channels and transmit 16 channels of Dante AoIP at 48 kHz or 44.1 kHz audio sample rates. 48 kHz is the iAM default rate.

Sample rate selection is left up to the Dante™ Controller device or software. *All devices connected to each other through a Dante network must be set to the same sample rate.* Slight ticking may be heard in the iAM-12G-SDI monitor when monitoring different input types at different sample rates or if sources are asynchronous.

Dante™ Device Setup

The iAM-12G-SDI's default **Dante Device Name** is "BKLYN-II- ..." followed by the last 6 digits of the Dante port MAC address, as shown in Figure B-2. This name can be changed by the Dante Controller to appear that way on the network, but that will not change the iAM-12G-SDI's unit name appearing on GUI pages and iAM-12G-SDI **Remote Metering** or **Discovery** pages.

Figure B-2: iAM-12G-SDI Name

Dante Device Name

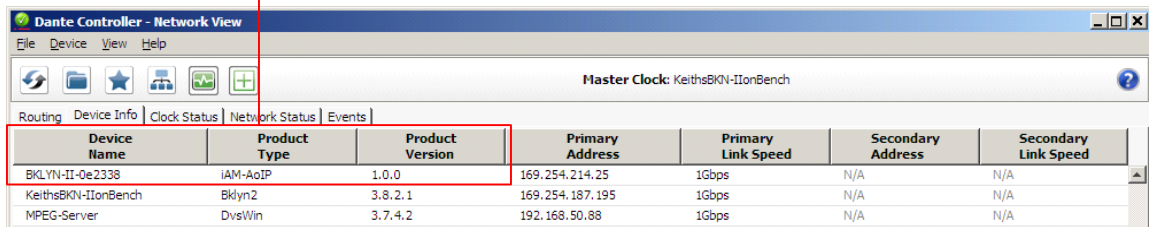

Device Name	Product Type	Product Version	Primary Address	Primary Link Speed	Secondary Address	Secondary Link Speed
BKLYN-II-0e2338	iAM-AoIP	1.0.0	169.254.214.25	1Gbps	N/A	N/A
KeithsBKN-IionBench	Bklyn2	3.8.2.1	169.254.187.195	1Gbps	N/A	N/A
MPEG-Server	DvsWin	3.7.4.2	192.168.50.88	1Gbps	N/A	N/A

During initial setup, you may want to manually change the iAM unit **Name** in the [System Setup](#) page to match the reassigned **Dante Device Name** for consistency. Refer to Figure B-3.

Figure B-3: Rename iAM

Change the iAM AoIP Name

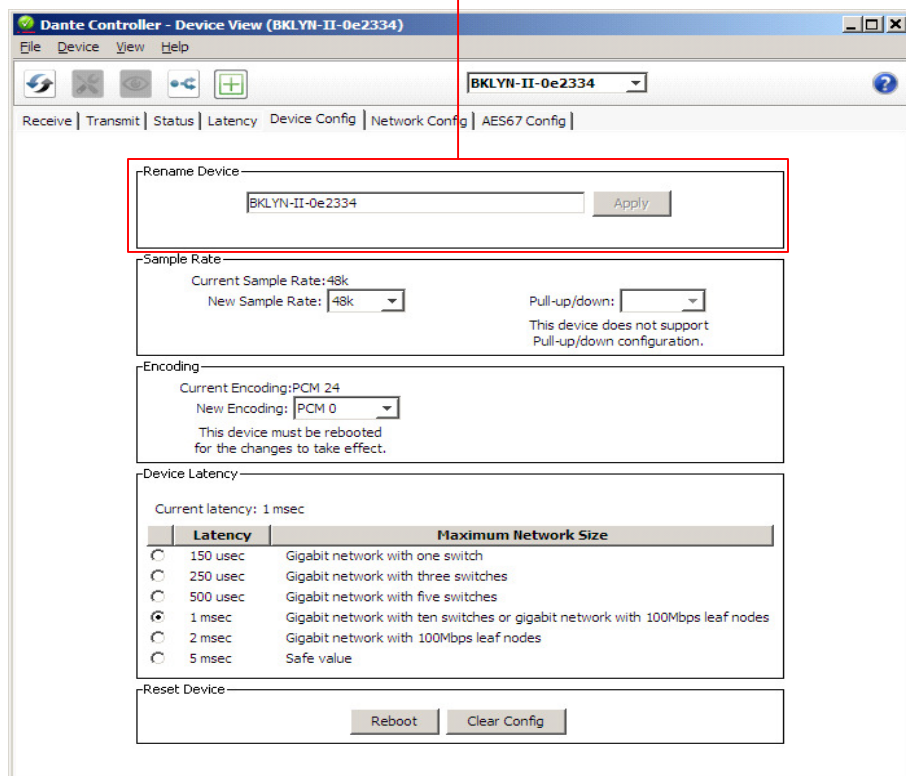

Rename Device

BKLYN-II-0e2334

Sample Rate

Current Sample Rate: 48k
New Sample Rate: 48k

Encoding

Current Encoding: PCM 24
New Encoding: PCM 0

Device Latency

Current latency: 1 msec

Latency	Maximum Network Size
<input type="radio"/> 150 usec	Gigabit network with one switch
<input type="radio"/> 250 usec	Gigabit network with three switches
<input type="radio"/> 500 usec	Gigabit network with five switches
<input checked="" type="radio"/> 1 msec	Gigabit network with ten switches or gigabit network with 100Mbps leaf nodes
<input type="radio"/> 2 msec	Gigabit network with 100Mbps leaf nodes
<input type="radio"/> 5 msec	Safe value

Reset Device

Other changes such as **Latency** settings can be made by the Dante Controller through the **Device View** menus. Some changes may require remote rebooting of the Brooklyn II card to take effect, temporarily interrupting audio and publishing the new information to the network.

Important:

Only 44.1 kHz and 48 kHz audio sample rates are currently supported by the iAM-12G-SDI. The Brooklyn II card would accept a Dante Controller command to operate at other rates, without giving an indication it will not be implemented. By design, this monitor will only plug into a

Dante Clock Selection

While the Brooklyn’s internal clock is highly accurate, the iAM-12G-SDI does not have provisions for external sync clocks, such as those that are GPS or media reference (video genlock or audio word clock) based. So it is generally not the best candidate to be the PTP Master Clock (commonly called the “grandfather clock”) for the network. It can be set as the preferred master if no better clock source exists. Refer to Figure B-4.

The iAM Brooklyn Dante card will serve as a temporary fallback clock source if preferred masters are interrupted. It functions as an accurate slave clock synchronized to the master clock on the network when not operating as the master.

Figure B-4: Clock Selection

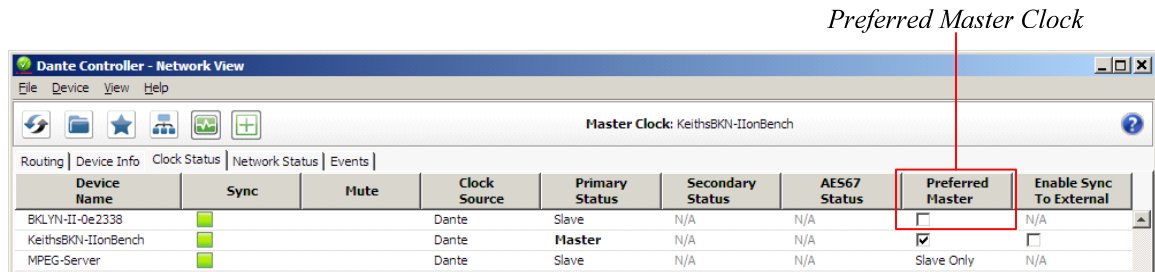

Channel Names

The iAM-12G-SDI uses the BKLYN-II default network channel names of Tx 01-16 and Rx 01-64. The network controller can change these names as desired, but iAM channel selections will remain as the original default numbers, unless changed in the [Channel Naming - AoIP](#) page. Note these iAM-12G-SDI internal channel names are not passed to the Dante network for discovery purposes, and are internal to the iAM-12G-SDI.

It is recommended for best operator understanding and system administrator reference that channel name changes made over the Dante network be manually entered in the iAM-12G-SDI **Channel Naming - AoIP** page to match.

AES67

The iAM-12G-SDI Brooklyn II can be configured for AES67 operation. AES67 operation with Dante is limited to eight or less receive and transmit channels at 48 kHz sample rates.

24 bit linear (L24) encoding and 1 msec packet time are fixed default transmit parameters.

16 bit (L16) or 24 bit (L24) encoding and 125/250/333/100 µsec packet times can be received.

The **Device View - AES67 Config** menu enables/disables AES67.

Figure B-5: AES67 Enable/Disable

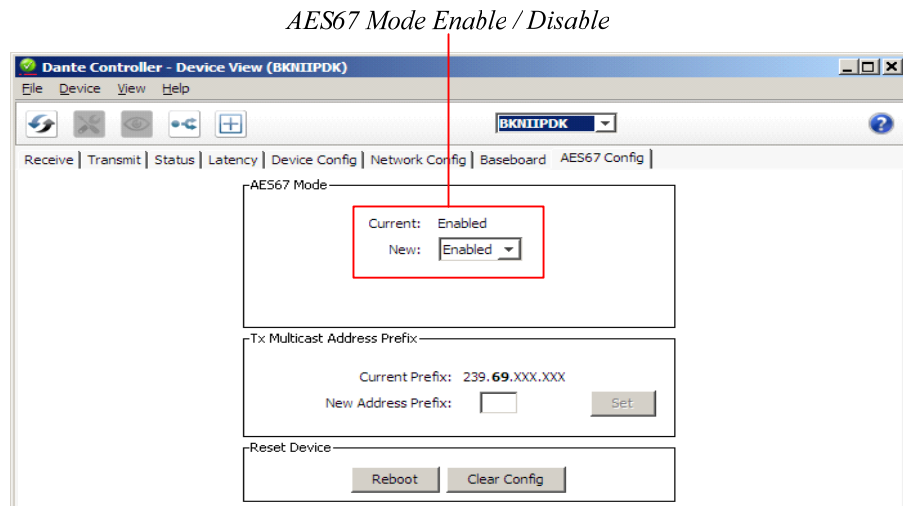

Further, Dante AES67 discovery and operational protocol requires manual assignments for static multicast transmit and receive IP addresses per Dante protocols for discovery and IGMP network operation. Destination addresses in range 239.nnn.0.0 – 239.nnn.255.255, port 5004 o nnn can be configured using the Dante Controller. The default is 69. The destination and receive address range must match. Provisions for this are in **Dante Controller Device View - Network Config**. Refer to Figure B-6.

Figure B-6: Device View - Network Config

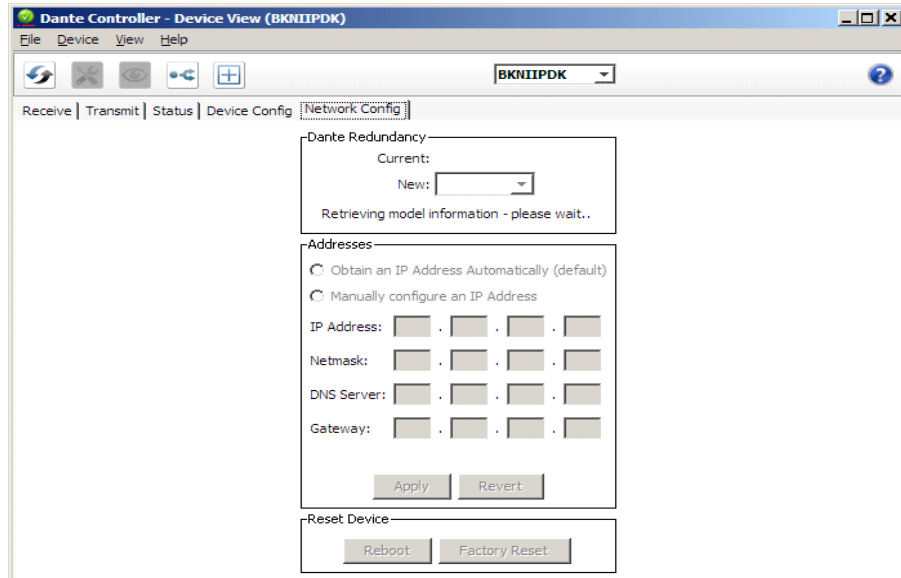

The channels to be multicast are selected in the File menu-**Create Multicast Flows** window shown in Figure B-7.

Figure B-7: Multicast

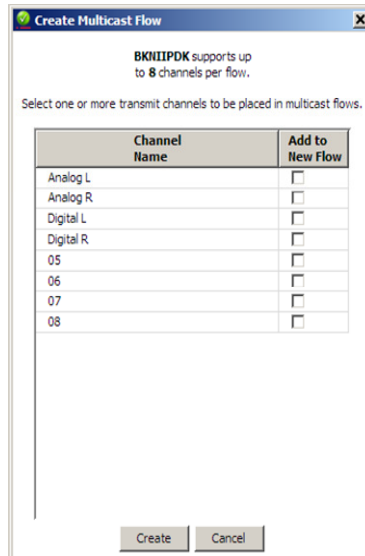

Device Lock

Audinate recently added a feature whereby a remote controller can send a command to lock Dante network device configurations. The iAM-12G-SDI does not implement the Device Lock command at this time.

Dante Firmware Upgrades

Wohler iAM-12G-SDI monitors ship with current Brooklyn II firmware as of the option installation date. The version information is found in the **Dante Controller Device View-Status** page. iAM software/firmware is tested with the latest Dante code release. Therefore it is strongly recommended that iAM-12G-SDI and Dante software/ firmware be updated at the same time to ensure compatibility and support of the latest features.

Use the Audinate **Dante Firmware Update Manager** Windows or OS X application to update the Dante firmware over the Dante network. Follow the application's installation and usage guide plus any applicable technical notes available.

Follow the instructions in [Software Upgrades](#) for iAM-12G-SDI updates.

Additional Information

The following links are provided for those who need more information about the Dante controller or the Dante Firmware update manager.

<https://my.audinate.com/products/firmware-update-manager>

<https://www.audinate.com/products/software/dante-controller>

<https://dev.audinate.com/GA/dante-controller/userguide/pdf/latest>

Dante™ Legal Disclosures

TRADEMARK ATTRIBUTION: Products covered in the manual include licence from Audinate Pty Ltd under US Patents 7747725, 8005939, 7978696, 8171152, European Patent 2255541, Chinese Patent ZL200780026677.0 and other patents pending or issued, see www.audinate.com/patents or such other legend as Audinate may stipulate from time to time to the Manufactured Product and any packaging and marketing materials therefor.

APPENDIX D: Ravenna (ZMAN) Setup

Introduction

Installing the iAM-12G-SDI into an existing and functioning Ravenna network using the Merging ZMAN Card is virtually plug and play. The iAM rear panel AoIP jack supports 1Gb/s and 100Mb/s Ethernet devices in Ravenna Audio over IP network configurations.

iAM-12G-SDI channel source selections are made by choosing **Input Type 'AoIP'** in the [Configuration-Configure Presets](#) page regardless of which AoIP option is installed.

Note: In addition to the iAM-12G-SDI configuration, the Merging ZMAN Card needs to be configured using its own configuration tool. The menus in this configuration tool are shown in this Appendix.

What is in the iAM-12G-SDI for Ravenna

The AES67 enabled Merging ZMAN Card supports the following features:

RAVENNA-Compatible Talker/Listener

- 1) RFC 3551 – RTP Profile for Audio and Video Conferences
 - a) L16 16-bit linear format defined in RFC 3551 clause 4.5.11
 - b) L24 24-bit linear format defined in RFC 3190 clause 4
 - c) AM824 24-bit Audio as defined in IEC61883-6
 - d) Multicast and unicast session support
 - e) 48 kHz and 96 kHz audio sampling rates
 - f) 1 to 8 audio channels per stream
 - g) Up to 64 streams
- 2) Media clock support
 - a) 48 kHz and 96 kHz
- 3) Hitless Stream Redundancy
- 4) IGMP v3 support
- 5) Session Announcement Protocol (SAP) support

AVB Ethernet Features

AVB uses the concept of streams and channels. A stream is a connection from one talker to one or more listeners. One stream can be made up of 1-60 audio channels. The Ravenna option supports the following AVB features:

- 1) AVB 1722 AVTP with multiple subtypes:
 - a) IEC 61883-6 MBLA
 - b) AM824, 24-bit Audio Encapsulation
 - c) Support up to 64 streams
 - d) Up to 8 channels per stream

- e) 512+512 Channels of audio
- f) 48kHz and 96kHz sampling rates
- 2) IEEE 802.1Q/SRP
- 3) IEEE 1722.1/AVDECC control
- 4) IEEE 802.1AS/gPTP
- 5) Compatible with Apple OS X devices, such as MacBooks and MacMini computers
- 6) Media clock per the AVnu specification
- 7) Hitless stream redundancy

Configuring the AOIP Merging Option Card

This appendix provides basic information about configuring the Merging ZMAN card by invoking the card's internal configuration application. The Merging card can be configured through a connection to the Ethernet AOIP Port using a browser on the Ravenna network and by using the Merging Aneman Windows application. Aneman is available for free download at:

<https://www.merging.com/support/downloads#aneman>

The iAM-12G-SDI can be configured using its Front Panel controls or its web interface through its Management port. Details specific to the iAM-12G-SDI can be found in Chapters 2 and 4 of this manual.

For a Quick Start, set the Source Select menu item on the Front Panel to AOIP to configure iAM-12G-SDI to receive/source a Ravenna Stream over its AOIP port. The Source Select Menu control also allows selection of a range of channels in groups of 16 channels 1-16 ... 49-64. More details including definition of Presets and individual channel parameters are available by reference to other chapters of this manual.

The Merging Ravenna card runs specific firmware from Merging and augmented by Wohler for use within the iAM-12G-SDI. The card will not function correctly if the user downloads and installs firmware from any source besides Wohler. The Wohler augmentation includes the ability to support 64 channels.

The Merging card is pre-configured to DHCP mode to obtain its IP address automatically from the Ravenna network. The Ravenna network should be a separate address space from the iAM-12G-SDI Management port. For example, the iAM-12G-SDI might be connected to a 10.11.11 subnet and the Ravenna network devices connected together on a 10.15.15 subnet. Aneman and a suitable browser must be resident on a host workstation on the same Ravenna subnet to access the Merging card. For this Appendix, the Ravenna network address will be referred to as <Ravenna subnet>. The Merging card address will then be <Ravenna subnet>.x where x is the specific address of the card on the subnet.

Power the iAM-12G-SDI and verify the Ethernet connector LEDs are lit and/or blinking. It may take a few minutes for the card to be fully recognized on the Ravenna network after powering the iAM-12G-SDI.

For Aneman access, the card parameters including its IP address should appear in a panel at the bottom of the screen. In Aneman, make sure Devices under Menu

item View is enabled. Do not proceed until the card shows on Aneman. Right click on that line and select Web Services: Advanced (or Ravenna) to bring up the Merging Ravenna configuration page. Also, the ICON of the card will appear in the main part of the Aneman screen. Double Clicking on the ICON also will load the Configuration screen.

For browser access, the URL is <Ravenna subnet>.x/advanced/index.html. This brings up the Merging Ravenna configuration page. Each tab is explained in the following sections.

Getting Started | General Settings

This tab is shown in the following figure.

Figure D-1: Getting Started | General Settings

General settings | PTP | Session sources | Session sinks | Ins/Outs | Debug

Audio Configuration

Sample rate: 48 kHz
Frame size (@1Fs): 48 smpl AES67(1ms)

Session Sinks Global

Safety Playout Delay (@1Fs): 0
SSM (requires IGMP v3):

Device Name

This is the unique zeroconf device name. Other devices see this device name.

Network Interface

Type: Zeroconf
Address: 169.254.80.179
Netmask: 255.255.0.0
Gateway: 0.0.0.0

Apply

Note: changing the network settings require a reboot of the device.

The elements of this tab are as follows:

1. **Device Name:** Enter a useful Device Name for the card, which will show up on other Ravenna devices on the subnet.
2. **Sample Rate:** (44100-48000- 88200-96000-176400-192000-352800-384000)
3. **Frame size (@1Fs):** current frame size (64 - AES67/48 - 32 -16 - 12 -6).
4. **Safety Playout Delay (@1Fs):** The value is described at 1Fs (44.1-48 kHz) in samples. For example, if the value is 10, the additional playout delay will be 20 at 2Fs (88.2-96 kHz), 40 at 4Fs (176.4-192 kHz)
5. **SSM Source-Specific Multicast:** If needed, configure the network switch for IGMP V3.
6. **Network Interface:** Note the address of the card and its type (Zeroconf, DHCP, Static). (If necessary, the address can be changed to another type such as a Static address which must include a Network Mask and Gateway.)

Getting Started | PTP

This tab is shown in the following figure. This configuration page refers to how your Ravenna network is synchronized to clocks.

Figure D-2: Getting Started | PTP

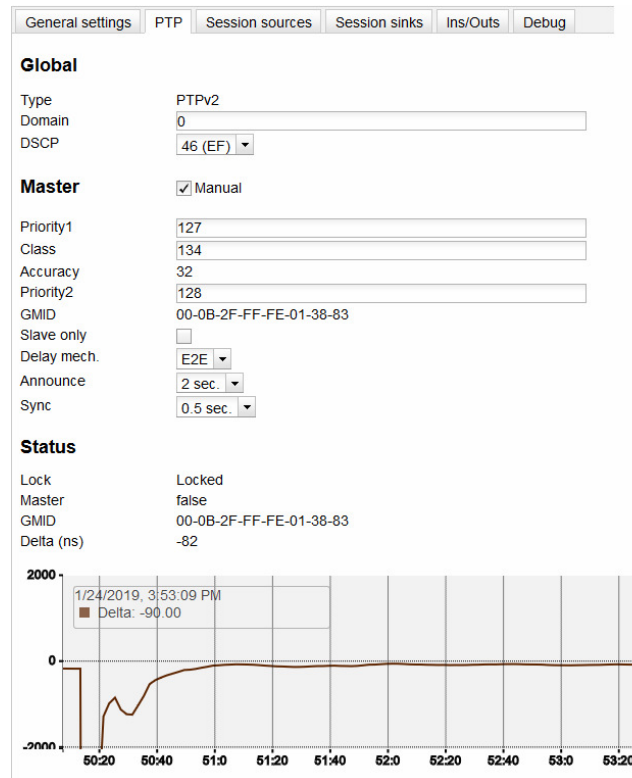

The elements of this tab are as follows:

- Global Settings:** The default value for PTP
 - Domain:** For the Merging Ravenna card this value is 0.
 - DSCP:** 46 for PTP AES67 or 48 for PTP Ravenna.
- Master:** To modify the PTP setting, you must first check the "Manual" checkbox.
 - Priority:** 1 is the main priority value.
 - Class:** This is the Device class. This value should not be modified.
 - Accuracy:** This field cannot be modified.
 - Priority 2:** This is only used if the other parameters do not allow electing a PTP master.
 - GMID:** This is the current GrandMasterID (PTP Master)
 - Slave only:** This forces the Merging device to always be PTP slave.
 - Delay Mech.:** This is PTP Profile related - E2E or P2P
 - Announce:** This is PTP Profile related - PTP announcement interval (1 - 2 - 4 - 8 -16 seconds)
 - Sync:** This is PTP Profile related (0.0625 - 0.125 - 0.25 - 0.5 seconds)

3. Status:

- a. **Lock:** This shows if the device is locked to PTP (Locked -Locking - Unlocked)
 - b. **Master:** This is true or false for the current device.
 - c. **GMID:** This is the current GrandMasterID (PTP Master)
 - d. **Delta (ns):** This is the time delta between the device and the PTP master.
4. **Graph:** The graph is only active for slave devices and shows the device delta against Master PTP clock.
5. **PTP Priority Value:**
- a. 1 is the highest priority, 255 the lowest one.
 - b. Merging card is by default using Priority 127 when set as PTP Master and 255 when PTP slave.

Getting Started | Session Sources

This tab defines which Streams are to be Sourced from this card. It is shown in the following figure.

Figure D-3: Getting Started | Session Sources

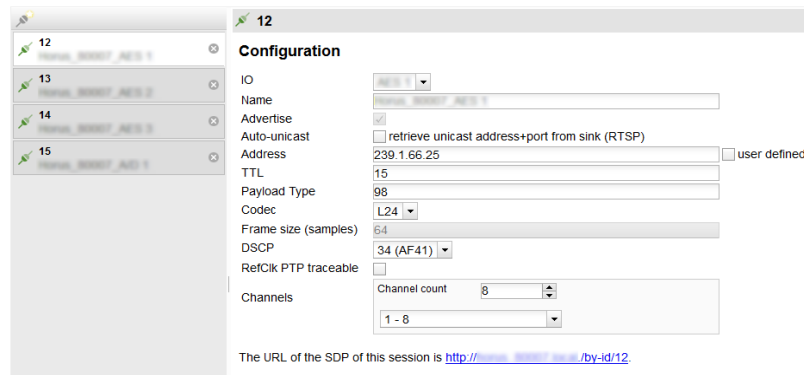

The elements of this tab are as follows:

1. **Create session button:** Create a new session sources by clicking on left ICON.
2. **IO:** Select the physical input (when applicable).
3. **Name:** This is the Source name.
4. **Advertise:** Check to enable source advertising on the network.
5. **Auto-unicast - (RTSP):** Check to automatically retrieve the sink (listener) IP address:port for unicast connection.
6. **Address:** This the stream's multicast address. Note that the user defined checkbox is activated automatically when entering a multicast address manually.
7. **TTL:** Time to Live (also called Hop Limit) - This value should not be modified.

8. **Payload type:** RTP Payload type - This value should not be modified.
9. **Codec:** The possible bit rate values are L24, L16, DSD64, DSD64_32, DSD128, DSD128_32, and DSD256. Note that these values are sampling rate dependent.
10. **Frame size (samples):** This the frame size of the current source.
11. **DSCP:** The audio DSCP should be set to 34 for RTP AES67 or 46 for RTP Ravenna.
12. **RefClk PTP traceable:** This feature is useful when you want to connect a stream through Internet (for example with two PTP Masters (GPS) at each location). This allows making connections with devices locked to different traceable PTP Masters. Refer also to Ignore RefClk GMID - accept source locked to any PTP master, on the Session Sinks tab.
13. **Channels:** This is the number of channels in the stream. The drop-down menu allows selection of specific channel range if the number of channels is less than 8.
14. **The URL of the SDP of this session:** This allows saving of the Session Description into a file, which is useful for specific third party devices if a manual SDP has to be provided.

Getting Started | Session Sinks

This tab defines streams which are sinked in this card. It is shown in the following figure.

Figure D-4: Getting Started | Session Sinks

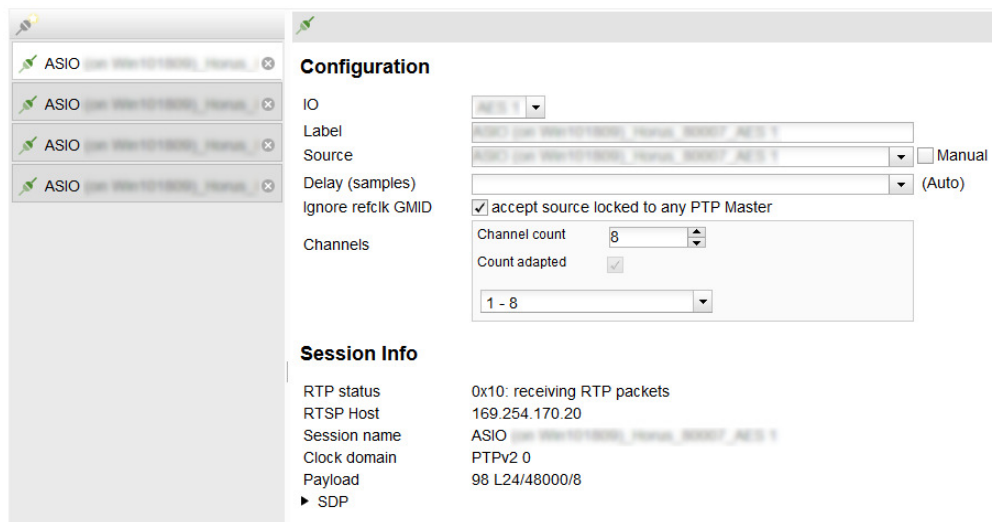

The elements of this tab are as follows:

1. **Create session button:** Create new session sinks by clicking on left ICON.
2. **IO:** Select the physical output (when applicable).
3. **Label:** This is the Sink name.
4. **Source:** This is a drop down menu to select a source (both sap and bonjour advertised sources are automatically listed).

5. **Manual:** This allows manual entry of an SDP.
6. **Delay (samples):** This sets the playback delay. 0 is automatic delay.
7. **Ignore RefClk GMID - accept source locked to any PTP master:** This feature is useful when you want to connect a stream through Internet (for example with two PTP Masters (GPS) at each location. This allows making of connections with devices locked to different traceable PTP Masters. See RefClk PTP traceable on the Session Sources tab.
8. **Channels:** Channel count: The drop-down menu allows selection of specific channel range if the number of channels is smaller than 8.

Getting Started | Session Info

1. **RTP Status:** The following bit positions indicate the connection status:
 - 0x10: receiving RTP packets (OK)
 - 0x01: wrong RTP sequence id
 - 0x02: wrong RTP SSRC
 - 0x04: wrong RTP payload type
 - 0x08: wrong RTP SAC
 - 0x20 stream has been muted
 - 0x40: Horus implementation - an incoming stream is muted

Important Note: The above error numbers are summed. For example, Stream Muted and Wrong Payload together are indicated by 0x24.

2. **Playout Delay:** This is the current playout delay on the selected sink in samples and ms.
3. **RTSP Host:** This is the connected source IP Session name: defined in SDP (usually the same as the source name)
4. **Clock Domain:** This is the PTP clock type and domain
5. **Payload:** Selections are Payload / Codec / Sampling Rate / Number of Channels
6. **SDP:** This displays detailed SDP information on the current stream.

Getting Started | Ins/Outs

This tab allows you to change the name of the specific Inputs and/or Outputs.

Figure D-5: Getting Started | Ins/Outs

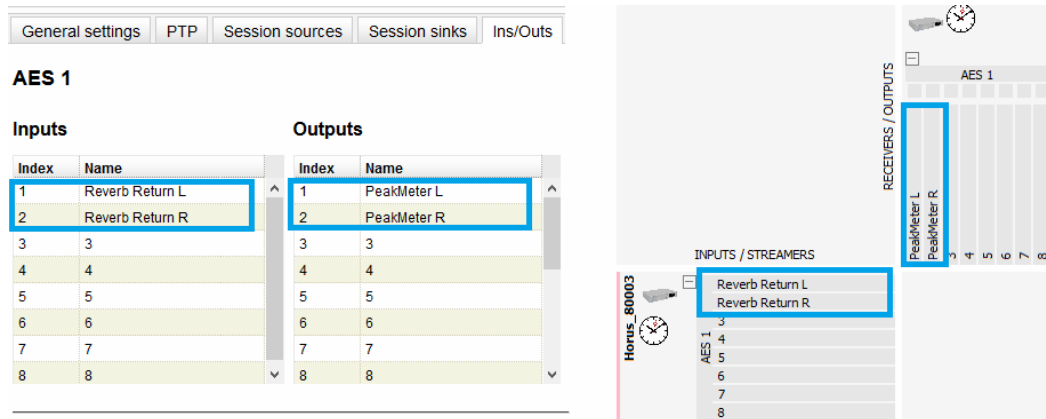

Getting Started | I/O Router

This page allows remapping of incoming channels to different internal channel assignments. For example, Stream channel 1 can be remapped to Merging card Channel 0, and so on.

Figure D-6: Getting Started | I/O Router

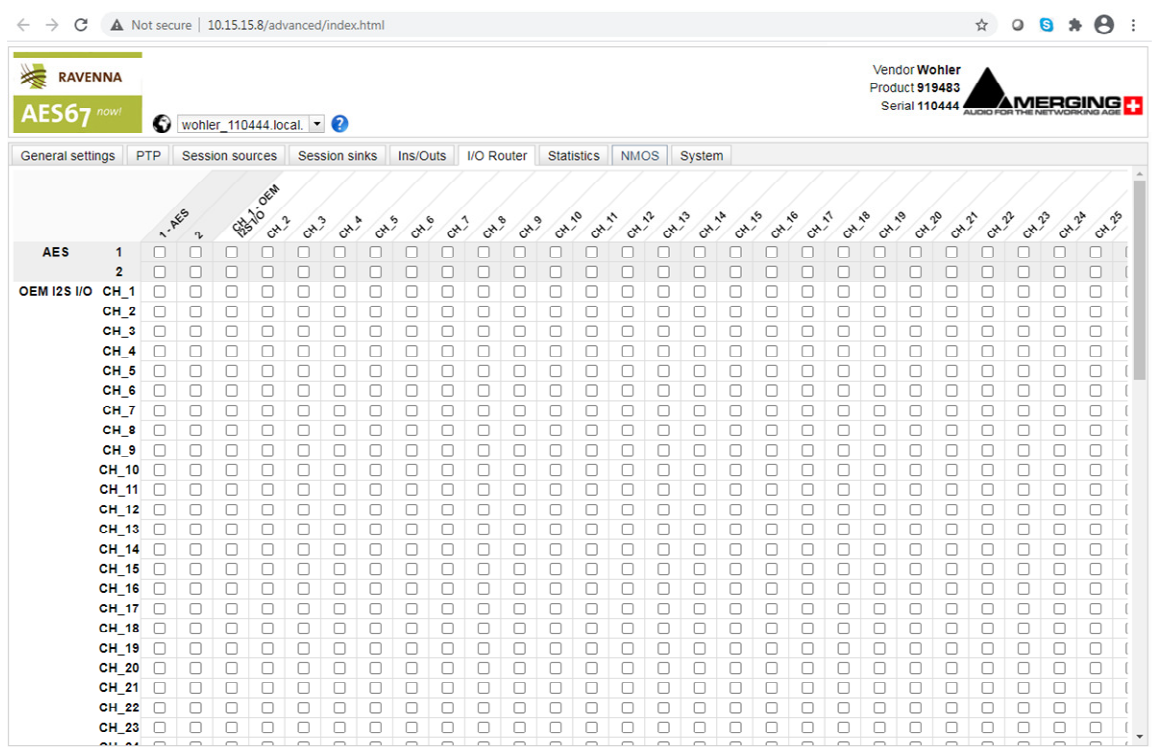

Operation:

Connecting Remote Source to Local Sink

This instruction assumes another Ravenna device is active on the network and sourcing a multicast stream. The Merging Configuration section for Session Sink controls how to configure the card to receive the stream and provide it to the IAM interface for display on meters and speakers, etc. The iAM-12G-SDI must be set to receive AOIP from the Source Select Front Panel menu or a browser iAM-12G-SDI GUI.

Ravenna Streams can contain up to 8 channels of information. The collections of channels in a specific Stream are termed Flows. For example, to source an SDI 16 channel signal might be accomplished by two Flows, each consisting of 8 channels. A stereo AES Flow consists of one Flow of two channels.

ZMAN Session Sinks

This assumes that 1 or more sources are present on the AOIP Ravenna network. Right Select Advanced on the entry for the Merging ZMAN device in Aneman. This brings up the browser page with tab set to General configuration GUI for the ZMAN card. This is shown in Figure D-1.

Use the following procedure:

1. Select the **Session Sinks** tab and use the **Create Session Sinks** icon (in the upper left corner) to see the available source Flows.
2. Create an entry on the left panel for each source Flow to be configured.
3. Select the desired Flow and set the number of channels in the Flow. Select the desired range to direct the Flow to the internal channels of the iAM-12G-SDI.
4. Click the matrix, as shown in Figure D-7, to direct the incoming channels to the desired iAM-12G-SDI channels.

For example, a 16 channel SDI source consists of two 8 channel Flows. One could be mapped to channels 1-8 and the other could be mapped to 9-16.

Notice that the Tab I/O Router duplicates the Session Sinks matrix and can be used to map channels from input source assignments to iAM-12G-SDI channels also.

Input channels can be mapped to more than one iAM-12G-SDI channel by selecting additional matrix elements to map input channels 1-8 to both 1-8 and 9-16.

Figure D-7: Session Sinks Tab

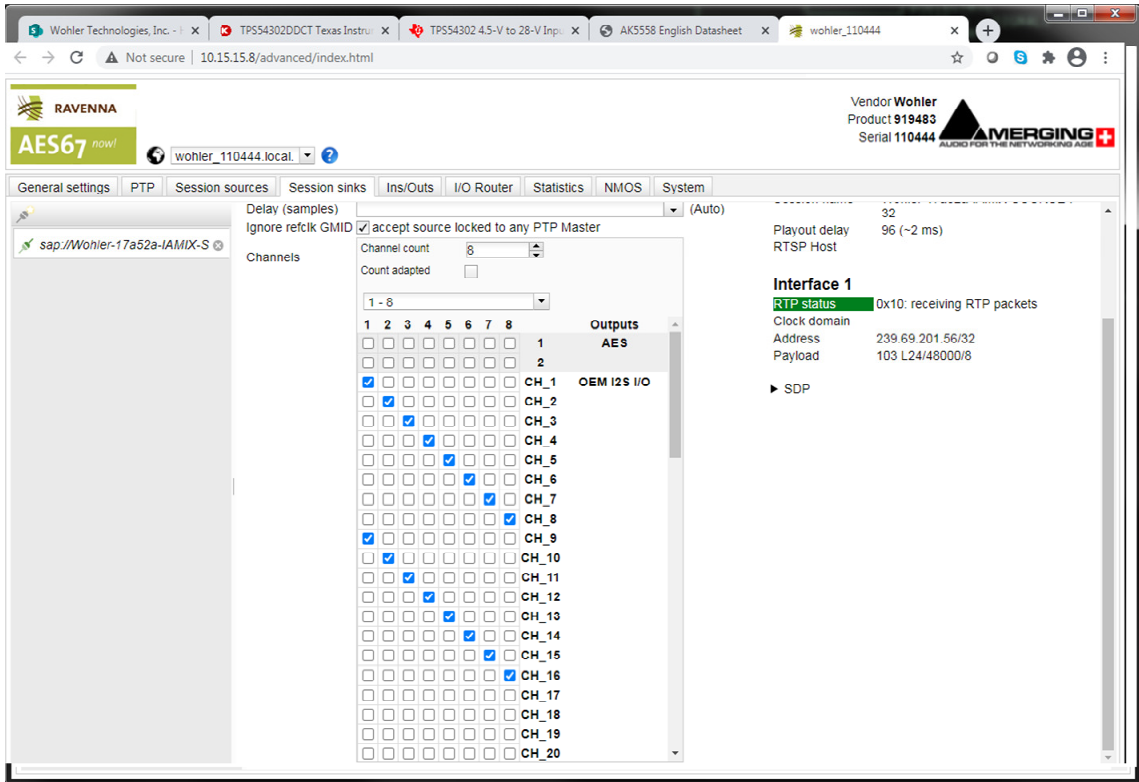

To avoid confusion if monitoring more than one Flow, especially if the various source Flows have overlapping channel numbers, use the matrix to direct Flows to higher channel ranges. For example, for monitoring 2 SDI sources (four 8 channel Flows), assign two flows to 1-8 and 9-16 and the next SDI signal to 17-24 and 25-32. Touch the iAM-12G-SDI AOIP selection menu to select the proper range to monitor, up to 57-64.

Select **Apply** to enable the Sink process, which results in the meters and audio becoming available on the iAM-12G-SDI.

ZMAN Session Sources

If the ZMAN card is to Source Flows, use the **Session Sources** tab. Refer to Figure D-8. The procedure is similar to defining Sinks with the additional step to provide the Flow a name to appear on other units in the network. Select the channel range with a maximum of 8 channels per Flow.

Figure D-8: Session Sources Tab

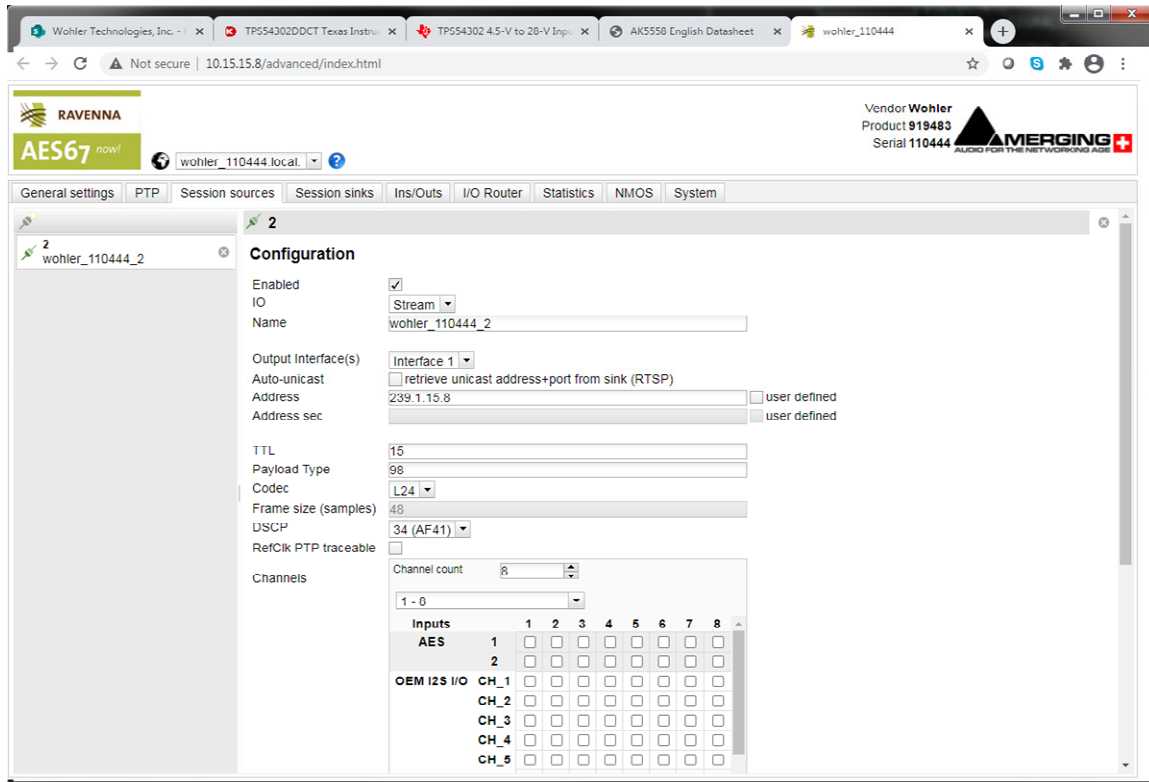

ZMAN Updating

The Zman card is pre-initialized with the correct Wohler firmware load. In case of future upgrades, use the following steps:

1. In Aneman, right click the ZMAN entry on the bottom Devices section, and select Maintenance Mode. This brings up a web page which prompts for the location of the Wohler provided upgrade file. The file should resemble the following:

firmware_1.1.7b43263_18Jun20.wohler

2. Select this file and click Open. On the web, select Update to install the firmware.
3. After successful completion, select Reboot to reboot the ZMAN card.
4. Close the web pages and return to Aneman to set up Sources and Sinks.

APPENDIX E: API Documentation

Introduction

This appendix discusses ways to use the Application Program Interface (API) to allow third party equipment to remotely access options and settings of the iAM-12G-SDI. It includes specific code examples for commonly used requests. The API uses JavaScript Object Notation (JSON) as its communication language.

Follow the instructions in the **First Time IP Assignments** section of Chapter 4 to achieve the required network connection.

API: Presets

1. GET Active Preset

Method: GET

/api/cf/presets/current

Example Response:

```
{
  "serial_number": "",
  "model": "iAM-12G-SDI",
  "version": 1.3,
  "name": "iAM-12G-SDI",
  "result": {
    "group": {
      "Id": 1,
      "Name": ""
    },
    "preset": {
      "Data": null,
      "Favorite": 0,
      "Id": 1,
      "Name": ""
    }
  }
}
```

2. GET Preset Configuration

Method: GET

/api/cf/presets/<int:preset ID>

Example Response:

```
{
```

```

"error": null,
"params": {
  "PresetId": 1
},
"result": {
  "GroupId": 1,
  "PresetName": "SDI",
  "Data": {
    "Name": {
      "Program": "",
      "Group": "G1",
      "Preset": "SDI"
    },
    "VideoSource": {
      "InputNo": 1,
      "ConnectorType": "BNC",
      "Slot": 1,
      "Type": "SDI",
      "Cage": 1
    },
    "DolbyDetection": {
      "NonAudio": "Enabled",
      "PaHeader": "Enabled"
    },
    "Clusters": [
      {
        "NumberOfMeters": 2,
        "FirstMeter": 1,
        "Name": "Stereo 2.0 #1",
        "Type": "Stereo",
        "MuteOnPresetRecall": true
      },
      {
        "NumberOfMeters": 2,
        "FirstMeter": 3,
        "Name": "Stereo 2.0 #2",
        "Type": "Stereo",
        "MuteOnPresetRecall": true
      },
      {
        "NumberOfMeters": 2,
        "FirstMeter": 5,
        "Name": "Stereo 2.0 #3",
        "Type": "Stereo",
        "MuteOnPresetRecall": true
      },
      {
        "NumberOfMeters": 2,
        "FirstMeter": 7,
        "Name": "Stereo 2.0 #4",
        "Type": "Stereo",
        "MuteOnPresetRecall": true
      },
      {
        "NumberOfMeters": 2,
        "FirstMeter": 9,
        "Name": "Stereo 2.0 #5",
        "Type": "Stereo",

```



```

    "MuteOnPresetRecall": true
  },
  {
    "NumberOfMeters": 2,
    "FirstMeter": 11,
    "Name": "Stereo 2.0 #6",
    "Type": "Stereo",
    "MuteOnPresetRecall": true
  },
  {
    "NumberOfMeters": 2,
    "FirstMeter": 13,
    "Name": "Stereo 2.0 #7",
    "Type": "Stereo",
    "MuteOnPresetRecall": true
  },
  {
    "NumberOfMeters": 2,
    "FirstMeter": 15,
    "Name": "Stereo 2.0 #8",
    "Type": "Stereo",
    "MuteOnPresetRecall": true
  }
],
"MeterSet": {
  "13": {
    "Source": {
      "Slot": 1,
      "Cage": 1,
      "Channel": 13,
      "ConnectorType": "BNC",
      "InputNo": 1,
      "InputIndex": 0,
      "Type": "SDI"
    },
    "VolumeDb": 0,
    "DelayMs": 0,
    "Speaker": "Left"
  },
  "8": {
    "Source": {
      "Slot": 1,
      "Cage": 1,
      "Channel": 8,
      "ConnectorType": "BNC",
      "InputNo": 1,
      "InputIndex": 0,
      "Type": "SDI"
    },
    "VolumeDb": 0,
    "DelayMs": 0,
    "Speaker": "Right"
  },
  "2": {
    "Source": {
      "Slot": 1,
      "Cage": 1,
      "Channel": 2,

```

```

        "ConnectorType": "BNC",
        "InputNo": 1,
        "InputIndex": 0,
        "Type": "SDI"
    },
    "VolumeDb": 0,
    "DelayMs": 0,
    "Speaker": "Right"
},
"3": {
    "Source": {
        "Slot": 1,
        "Cage": 1,
        "Channel": 3,
        "ConnectorType": "BNC",
        "InputNo": 1,
        "InputIndex": 0,
        "Type": "SDI"
    },
    "VolumeDb": 0,
    "DelayMs": 0,
    "Speaker": "Left"
},
"4": {
    "Source": {
        "Slot": 1,
        "Cage": 1,
        "Channel": 4,
        "ConnectorType": "BNC",
        "InputNo": 1,
        "InputIndex": 0,
        "Type": "SDI"
    },
    "VolumeDb": 0,
    "DelayMs": 0,
    "Speaker": "Right"
},
"16": {
    "Source": {
        "Slot": 1,
        "Cage": 1,
        "Channel": 16,
        "ConnectorType": "BNC",
        "InputNo": 1,
        "InputIndex": 0,
        "Type": "SDI"
    },
    "VolumeDb": 0,
    "DelayMs": 0,
    "Speaker": "Right"
},
"11": {
    "Source": {
        "Slot": 1,
        "Cage": 1,
        "Channel": 11,
        "ConnectorType": "BNC",
        "InputNo": 1,

```

```

        "InputIndex": 0,
        "Type": "SDI"
    },
    "VolumeDb": 0,
    "DelayMs": 0,
    "Speaker": "Left"
},
"15": {
    "Source": {
        "Slot": 1,
        "Cage": 1,
        "Channel": 15,
        "ConnectorType": "BNC",
        "InputNo": 1,
        "InputIndex": 0,
        "Type": "SDI"
    },
    "VolumeDb": 0,
    "DelayMs": 0,
    "Speaker": "Left"
},
"5": {
    "Slot": 0,
    "Cage": 0,
    "ConnectorType": "None",
    "Source": {
        "Slot": 1,
        "Cage": 1,
        "Channel": 5,
        "ConnectorType": "BNC",
        "InputNo": 1,
        "InputIndex": 0,
        "Type": "SDI"
    },
    "VolumeDb": 0,
    "DelayMs": 0,
    "Speaker": "Left"
},
"9": {
    "Source": {
        "Slot": 1,
        "Cage": 1,
        "Channel": 9,
        "ConnectorType": "BNC",
        "InputNo": 1,
        "InputIndex": 0,
        "Type": "SDI"
    },
    "VolumeDb": 0,
    "DelayMs": 0,
    "Speaker": "Left"
},
"14": {
    "Source": {
        "Slot": 1,
        "Cage": 1,
        "Channel": 14,
        "ConnectorType": "BNC",

```

```

        "InputNo": 1,
        "InputIndex": 0,
        "Type": "SDI"
    },
    "VolumeDb": 0,
    "DelayMs": 0,
    "Speaker": "Right"
},
"6": {
    "Source": {
        "Slot": 1,
        "Cage": 1,
        "Channel": 6,
        "ConnectorType": "BNC",
        "InputNo": 1,
        "InputIndex": 0,
        "Type": "SDI"
    },
    "VolumeDb": 0,
    "DelayMs": 0,
    "Speaker": "Right"
},
"7": {
    "Source": {
        "Slot": 1,
        "Cage": 1,
        "Channel": 7,
        "ConnectorType": "BNC",
        "InputNo": 1,
        "InputIndex": 0,
        "Type": "SDI"
    },
    "VolumeDb": 0,
    "DelayMs": 0,
    "Speaker": "Left"
},
"10": {
    "Source": {
        "Slot": 1,
        "Cage": 1,
        "Channel": 10,
        "ConnectorType": "BNC",
        "InputNo": 1,
        "InputIndex": 0,
        "Type": "SDI"
    },
    "VolumeDb": 0,
    "DelayMs": 0,
    "Speaker": "Right"
},
"12": {
    "Source": {
        "Slot": 1,
        "Cage": 1,
        "Channel": 12,
        "ConnectorType": "BNC",
        "InputNo": 1,
        "InputIndex": 0,

```

```

        "Type": "SDI"
    },
    "VolumeDb": 0,
    "DelayMs": 0,
    "Speaker": "Right"
},
"1": {
    "Source": {
        "Slot": 1,
        "Cage": 1,
        "Channel": 1,
        "ConnectorType": "BNC",
        "InputNo": 1,
        "InputIndex": 0,
        "Type": "SDI"
    },
    "VolumeDb": 0,
    "DelayMs": 0,
    "Speaker": "Left"
}
},
"SystemClockSource": {
    "Slot": 0,
    "Cage": 0,
    "ConnectorType": "None",
    "InputNo": 0,
    "Type": "None",
    "Pair": 0
}
},
"Favorite": 0,
"PresetId": 1,
"GroupName": "G1"
}
}
}

```

3. GET list of groups/presets

Method: GET

/api/cf/groups

Example Response:

```

{
  "error": null,
  "params": null,
  "result": [
    {
      "Name": "G1",
      "Presets": [
        {
          "Favorite": 1,
          "Name": "AES",
          "Id": 3
        },
      ],
    }
  ]
}

```

```

        "Favorite": 0,
        "Name": "SDI",
        "Id": 1
      }
    ],
    "Id": 1
  },
  {
    "Name": "AES",
    "Presets": [
      {
        "Favorite": 0,
        "Name": "dfsdf",
        "Id": 2
      }
    ],
    "Id": 2
  }
]
}

```

4. GET to recall the preset

Method: GET

/api/cf/presets/<int:presetID>/activate

Example Response:

```

{
  "error": null,
  "params": {
    "PresetId": 1
  },
  "result": {
    "PresetId": 1,
    "GroupId": 1,
    "PresetName": "SDI",
    "GroupName": "G1"
  }
}

```

5. POST to delete the group

Method: POST

api/op/group/<int:groupID>/delete

Example Response:

```

{
  "error": null,
  "params": {

```

```
    "GroupId": 2
  },
  "result": {
    "GroupId": 2
  }
}
```

6. POST to delete the preset

Method: POST

api/op/preset/<int:presetID>/delete

Example Response:

```
{
  "error": null,
  "params": {
    "PresetId": 4
  },
  "result": {
    "PresetId": 4
  }
}
```

7. POST to rename group

Method: POST

/api/op/group/<int:groupID>/newGrpNameSdi/rename

Example Response:

```
{
  "error": null,
  "params": {
    "GroupId": 1,
    "GroupName": "newGrpNameSdi"
  },
  "result": {
    "GroupId": 1,
    "GroupName": "newGrpNameSdi"
  }
}
```

8. POST to rename preset

Method: POST

/api/op/preset/<int:presetID>/newPresetNameTest/rename

Example Response:

```
{
  "error": null,
  "params": {
    "PresetId": 1,
    "PresetName": "newPresetNameTest"
  },
  "result": {
    "PresetId": 1,
    "PresetName": "newPresetNameTest"
  }
}
```

9. POST to set preset as Favorite

Method: POST

/api/op/preset/<int:presetID>/<favoriteVal>/favorite

Example Response:

```
{
  "error": null,
  "params": {
    "PresetId": 4,
    "Favorite": 1
  },
  "result": {
    "PresetId": 4,
    "Favorite": 1
  }
}
```

10. Source Select

Method: POST

/api/op/sourceselect

1. Body content for SDI/SMPTE-2022-6/ SMPTE-2110

```
{
  "SourceType": <String: SDI Input Source>
}
```

Note: Allowed SDI input sources are:

```
"Bnc-1.Sdi",
"Bnc-2.Sdi",
```

```
"Sfp-1.Sdi",
"Sfp-2.Sdi",
"Sfp-3.Sdi",
"Sfp-4.Sdi",
```

```
"Sfp-1.Smpte2022",
"Sfp-2.Smpte2022",
"Sfp-3.Smpte2022",
"Sfp-4.Smpte2022",
```

```
"Sfp-1.Smpte2110"
"Sfp-2.Smpte2110"
"Sfp-3.Smpte2110"
"Sfp-4.Smpte2110"
```

2. Body content for MADI

```
{
  "SourceType": <String: MADI Input Source>,
  "ChannelGroup": <Int: 1-4>
}
```

Note: Allowed MADI input sources are

```
"Madi.Coax" and
"Madi.Optical" .
```

ChannelGroup 1 => Channels 1-16 and

ChannelGroup 2 => Channels 17-32 and so on

3. Body content for Analog

```
{
  "SourceType": "Analog"
}
```

4. Body content for Aes

```
{
  "SourceType": "Aes"
}
```

5. Body content for Aoip

```
{  
  "SourceType": "Aoip",  
  "ChannelGroup": <Int: 1-16>  
}
```

Note: ChannelGroup 1 => Channels 1-16 and
ChannelGroup 2 => Channels 17-32 and so on

6. Body content for TOSLINK

```
{  
  "SourceType": "TOSLINK"  
}
```

11. Setting Mute/Unmute Clusters

Method: PATCH

/api/op/presets/<int:preset id>/mute-clusters

```
{  
  "clusters": [  
    {"name": "MADI 1", "mute": "N"},  
    {"name": "MADI 2", "mute": "N"},  
    {"name": "MADI 3", "mute": "Y"},  
    {"name": "MADI 4", "mute": "Y"}  
  ]  
}
```

12. Setting Solo Cluster

Method: PATCH

/api/op/presets/<int:preset ID>/solo-cluster

```
{  
  "cluster_name": "Test1"  
}
```

13. Setting Solo Channel

Method: PATCH

/api/op/presets/solo-channel

```
{  
    "channel_number":1  
}
```